



**THE
PREVENTIVE
MAINTENANCE
MONTHLY**

ISSUE 787 JUNE 2018



COMBAT VEHICLES 2

LRUs, Check for Serviceability Before Turn-in	3
Stryker PM Tips	4-5
M2/M3-Series Bradleys, M242 Service Only by 91Fs	6
M119A2/A3 Towed Howitzers, Blast Overprotection	7
M1-Series Tanks Battery PM	8-9



TACTICAL VEHICLES 10

FMTV, A/C Air Compressor Oil Leaks	11
Rust Busters Tip of the Month	12-13
M870A1 Semitrailer Hub and Drum Conversion Kit	14-15
M1101, M1102 Light Tactical Trailers, Brake Master Cylinder Cap Change	15



CONSTRUCTION 16

HMEE-1, Axle Swivel Grease Fitting Lube	17
Mine Detector Tips for Better Detecting	18-19



AVIATION 20

Gray Eagle UAV PM Tips	21
Black Hawk Rescue Hoist Needs Oil	22
AH-64, Unserviceable Repair Parts Turn-in Needed	23
AN/APX-123/123A Receiver-Transmitter, Clearing SAFT Low Battery Indicator	24-25
Inspect Bench Stock for Bad Hardware	26



SMALL ARMS 35

Small Arms PM Tips	36-38
SFL Pen for Small Arms Touch-ups	38
M3 Rifle TMs Available Online	38
Small Arms Turn-in, Check SMR Codes First	39
Weapons Camouflage Paint Guidance	40



TOOLS 41

Silicone Grease/Spray for O-rings, Grommets	41
---	----



MISSILES 42

M1134 ATGM Stryker, MITAS BITS Sequence	42-43
MLRS/HIMARS Newsletter	43



CBRN 44

M1135 NBCRV Stryker PM Tips	44-45
-----------------------------	-------



COMMUNICATIONS 46

AN/VAS-5 Series DVE Sensor Replacement	47
SINCGARS RT-1523E/F Mount Installation	48-49
SINCGARS Radio Installation Kit for PLS A1	49



SOLDIER SUPPORT 50

ECU's R22 Refrigerant Replaced for OCONUS	50-51
Body Armor Checks to Ensure Serviceability	52-54



LOGISTICS MANAGEMENT 55

Corrosion Prevention Method 20, CPC	56-57
Corrosion Prevention Method 50, Desiccant	58-60

PM Mission to Mars 27-34 Connie's Post Scripts 61

TB 43-PS-787, *The Preventive Maintenance Monthly*, is an official publication of the Department of the Army, providing information for all Soldiers assigned to combat and combat support units and all Soldiers with unit maintenance and supply duties. All information published has been reviewed and approved by the authority responsible for the equipment, publication or policy discussed. Application of the information is optional with the user. Masculine pronouns may refer to both genders. The use of product or company names does not constitute endorsement of those products, services or companies by the U.S. Army. The use of non-DoD hyperlinks, along with their content, does not constitute endorsement by DoD or DA. Neither DoD nor DA exercises any editorial control over, and cannot vouch for, content on non-DoD websites.

PS, The Preventive Maintenance Monthly (ISSN 0475-2953)
is published monthly by the Department of the Army, Redstone Arsenal, AL 35898.

You are invited to send PS your ideas for improving maintenance procedures, questions on maintenance and supply problems and questions or comments on material published in PS.

Just write to:

MSG Half-Mast
PS, the Preventive Maintenance Monthly
USAMC LOGSA (AMXLS-GP)
Bldg. 3303
Redstone Arsenal, AL 35898

Or email:

usarmy.redstone.logsa.mbx.psmag@mail.mil

Internet address:

https://www.logsa.army.mil/psmag/pshome.cfm

By order of the Secretary of the Army:

MARK A. MILLEY
General, United States Army Chief of Staff

Official:

GERALD B. O'KEEFE

Administrative Assistant to the Secretary of the Army

1808651

Issue 787

PS

★
June
2018

THE PREVENTIVE MAINTENANCE MONTHLY

TB 43-PS-787

Approved for
Public Release;
Distribution is
Unlimited

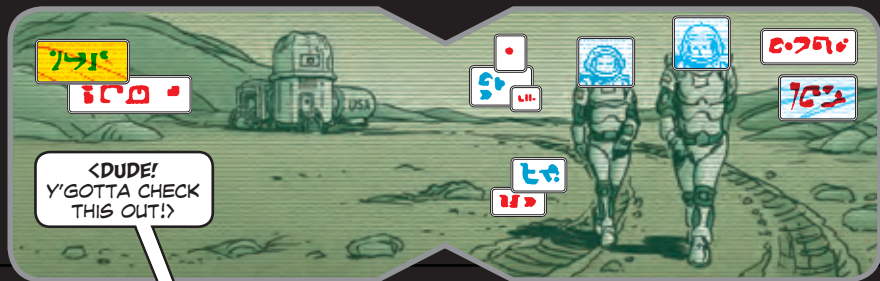

<DUDE!
Y'GOTTA CHECK
THIS OUT!>

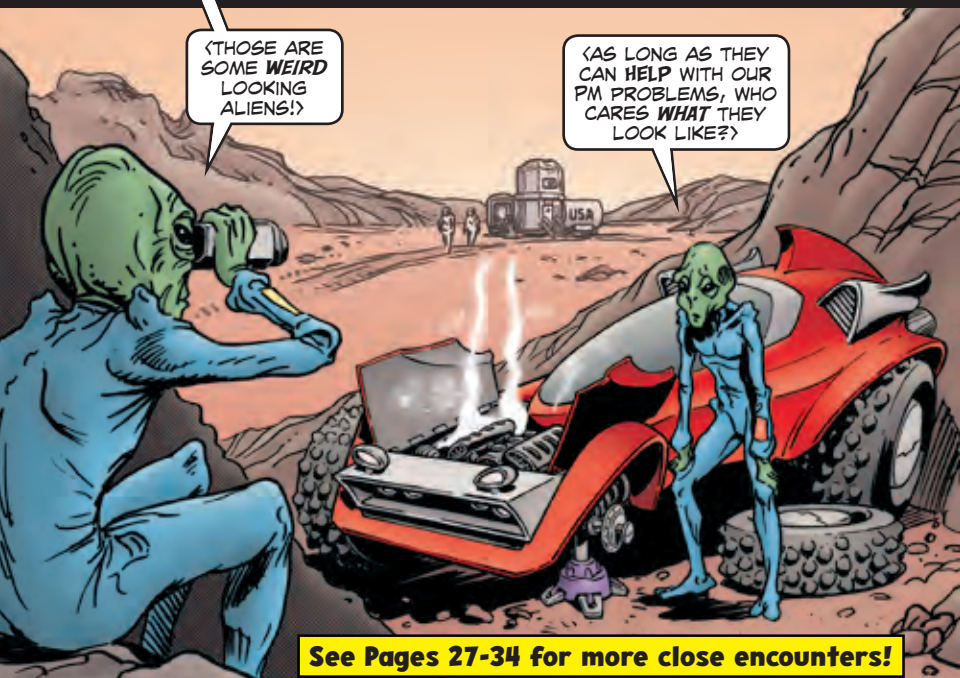

<THOSE ARE
SOME WEIRD
LOOKING
ALIENS!>

<AS LONG AS THEY
CAN HELP WITH OUR
PM PROBLEMS, WHO
CARES WHAT THEY
LOOK LIKE?>

See Pages 27-34 for more close encounters!

	COMBAT VEHICLES	2		
LRUs, Check for Serviceability Before Turn-in		3		
Stryker PM Tips		4-5		
M2/M3-Series Bradleys, M242 Service Only by 91Fs		6		
M119A2/A3 Towed Howitzers, Blast Overprotection		7		
M1-Series Tanks Battery PM		8-9		
	TACTICAL VEHICLES	10		
FMTV, A/C Air Compressor Oil Leaks		11		
Rust Busters Tip of the Month		12-13		
M870A1 Semitrailer Hub and Drum Conversion Kit		14-15		
M1101, M1102 Light Tactical Trailers, Brake Master Cylinder Cap Change		15		
	CONSTRUCTION	16		
HMEE-1, Axle Swivel Grease Fitting Lube		17		
Mine Detector Tips for Better Detecting		18-19		
	AVIATION	20		
Gray Eagle UAV PM Tips		21		
Black Hawk Rescue Hoist Needs Oil		22		
AH-64, Unserviceable Repair Parts Turn-in Needed		23		
AN/APX-123/123A Receiver-Transmitter, Clearing SAFT Low Battery Indicator		24-25		
Inspect Bench Stock for Bad Hardware		26		
	SMALL ARMS	35		
Small Arms PM Tips		36-38		
SFL Pen for Small Arms Touch-ups		38		
M3 Rifle TMs Available Online		38		
Small Arms Turn-in, Check SMR Codes First		39		
Weapons Camouflage Paint Guidance		40		
	TOOLS	41		
Silicone Grease/Spray for O-rings, Grommets		41		
	MISSILES	42		
M1134 ATGM Stryker, MITAS BITS Sequence		42-43		
MLRS/HIMARS Newsletter		43		
	CBRN	44		
M1135 NBCRV Stryker PM Tips		44-45		
	COMMUNICATIONS	46		
AN/VAS-5 Series DVE Sensor Replacement		47		
SINCGARS RT-1523E/F Mount Installation		48-49		
SINCGARS Radio Installation Kit for PLS A1		49		
	SOLDIER SUPPORT	50		
ECU's R22 Refrigerant Replaced for OCONUS		50-51		
Body Armor Checks to Ensure Serviceability		52-54		
	LOGISTICS MANAGEMENT	55		
Corrosion Prevention Method 20, CPC		56-57		
Corrosion Prevention Method 50, Desiccant		58-60		
PM Mission to Mars	27-34	Connie's Post Scripts	61	

TB 43-PS-787, The Preventive Maintenance Monthly, is an official publication of the Department of the Army, providing information for all Soldiers assigned to combat and combat support units and all Soldiers with unit maintenance and supply duties. All information published has been reviewed and approved by the agency responsible for the equipment, publication or policy discussed. Application of the information is optional with the user. Masculine pronouns may refer to both genders. The use of product or company names does not constitute endorsement of those products, services or companies by the U.S. Army. The use of non-DoD hyperlinks, along with their content, does not constitute endorsement by DoD or DA. Neither DoD nor DA exercises any editorial control over, and cannot vouch for, content on non-DoD websites.

PS, The Preventive Maintenance Monthly (ISSN 0475-2953) is published monthly by the Department of the Army, Redstone Arsenal, AL 35898.

You are invited to send PS your ideas for improving maintenance procedures, questions on maintenance and supply problems and questions or comments on material published in PS.

Just write to:
MSG Half-Mast
PS, the Preventive Maintenance Monthly
USAMC LOGSA (AMXLS-GP)
Bldg. 3303
Redstone Arsenal, AL 35898

Or email:
usarmy.redstone.logsa.mbx.psmag@mail.mil

Internet address:
https://www.logsa.army.mil/psmag/pshome.cfm

By order of the Secretary of the Army:
MARK A. MILLEY
General, United States Army Chief of Staff

Official:

GERALD B. O'KEEFE
Administrative Assistant to the Secretary of the Army

1808651

Easy Answers?

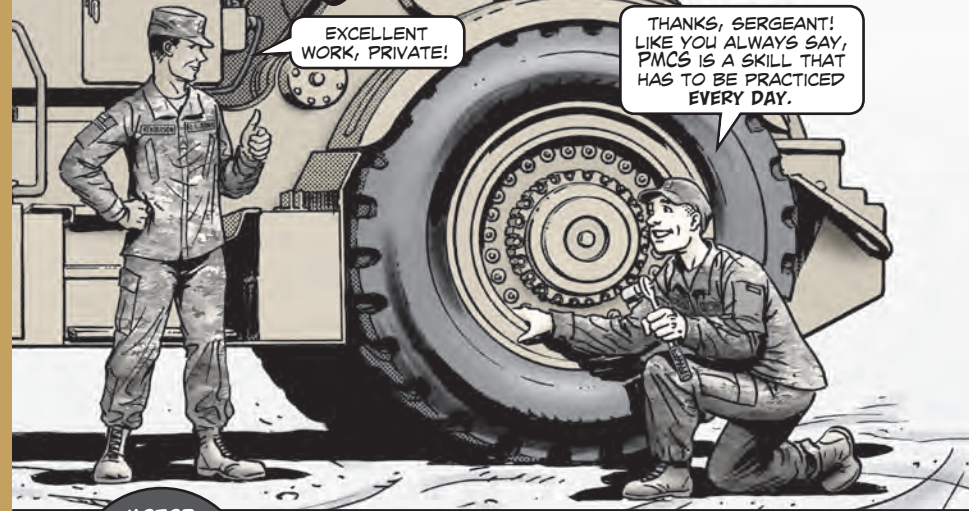

EXCELLENT WORK, PRIVATE!

THANKS, SERGEANT! LIKE YOU ALWAYS SAY, PMCS IS A SKILL THAT HAS TO BE PRACTICED EVERY DAY.

MOTOR SERGEANTS, YOU CAN DO THE OPERATORS IN YOUR UNIT A BIG FAVOR.

TRY CASUALLY WALKING AROUND THE MOTOR POOL WHILE ASKING QUESTIONS LIKE, "WHAT'S THE VERY FIRST CHECK IN THE PMCS CHART OF YOUR VEHICLE'S -10 TM?"

OR HOW ABOUT, "DO YOU HAVE THE LATEST COPY OF THE TM?"



THOSE SEEM LIKE SIMPLE QUESTIONS, BUT YOU MIGHT BE SURPRISED AT SOME OF THE ANSWERS YOU GET.

POINT IS, IF YOU'RE NOT HEARING THE RIGHT ANSWERS, IT'S TIME FOR SOME BRUSH-UP SUPERVISION TO HELP YOUR OPERATORS KEEP THEIR EQUIPMENT MISSION READY.

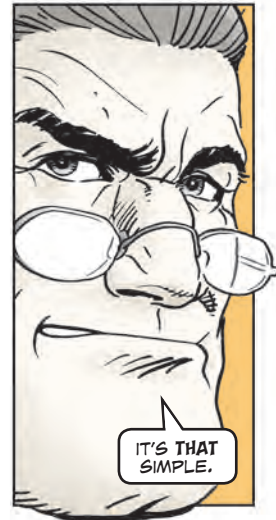

IT'S THAT SIMPLE.

- LRU Serviceable? Don't Turn It In!
- Stryker Suggestions for Success
- Who Services the M242?
- Keep Safe During Fire Missions!
- Don't Neglect Battery PM!



LRU SERVICEABLE? DON'T TURN IT IN!

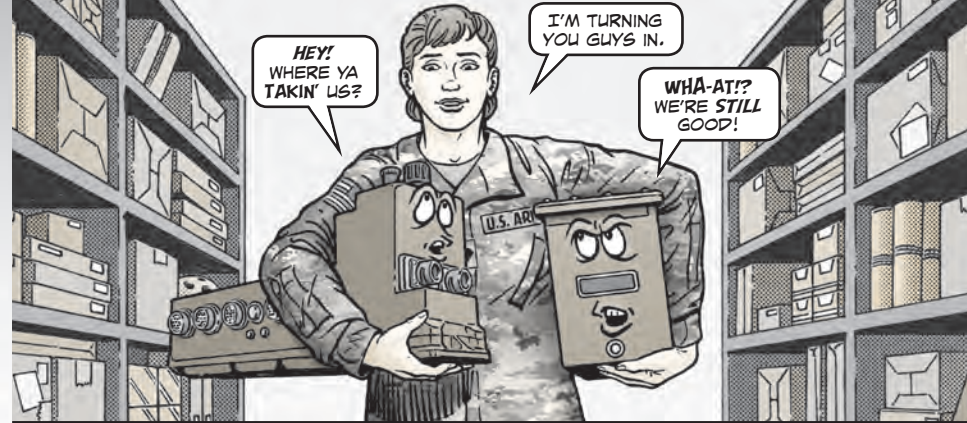

SOME UNITS ARE TURNING IN LINE REPLACEABLE UNITS (LRUs) AS **UNSERVICEABLE** WHEN THE LRUs ARE ACTUALLY IN WORKING CONDITION.

DON'T DO THAT!

TURNING IN SERVICEABLE LRUs **DRIVES UP COSTS** AND MAKES UNITS **SPEND MONEY UNNECESSARILY**. NOT TO MENTION THAT UNIT READINESS IS **HURT** AWAITING REPLACEMENT FOR A PERFECTLY GOOD LRU.

BEFORE TURNING IN LRUs, TEST THEM WITH THE NEXT GENERATION AUTOMATIC TEST SYSTEM (NGATS) OR THE DIRECT SUPPORT ELECTRICAL SYSTEM TEST SET (DSSETS).

MAKE A NOTE OF ANY FAULTS OR DEFICIENCIES ON THE DA FORM 5988-E OR DA FORM 2404 BEFORE TURN-IN TO YOUR SUPPLY SUPPORT ACTIVITY (SSA).

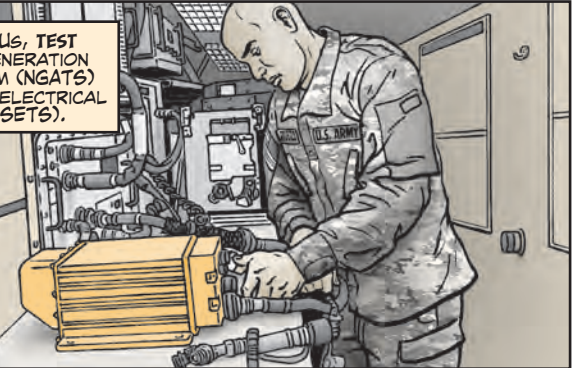

FOR THE **FULL SCOOP** ON TURNING IN LRUs, CHECK OUT TACOM MAINTENANCE INFORMATION MESSAGE (MIM) 18-002 AT:

QUESTIONS? CONTACT YOUR LOCAL TACOM LOGISTICS ASSISTANCE REPRESENTATIVE (LAR).

<https://tulsa.tacom.army.mil/Maintenance/message.cfm?id=MI18-002.html>

STRYKER SUGGESTIONS FOR SUCCESS

WANT YOUR STRYKER TO BE A SUCCESS?

LISTEN TO THESE TIPS FROM FT CARSON!

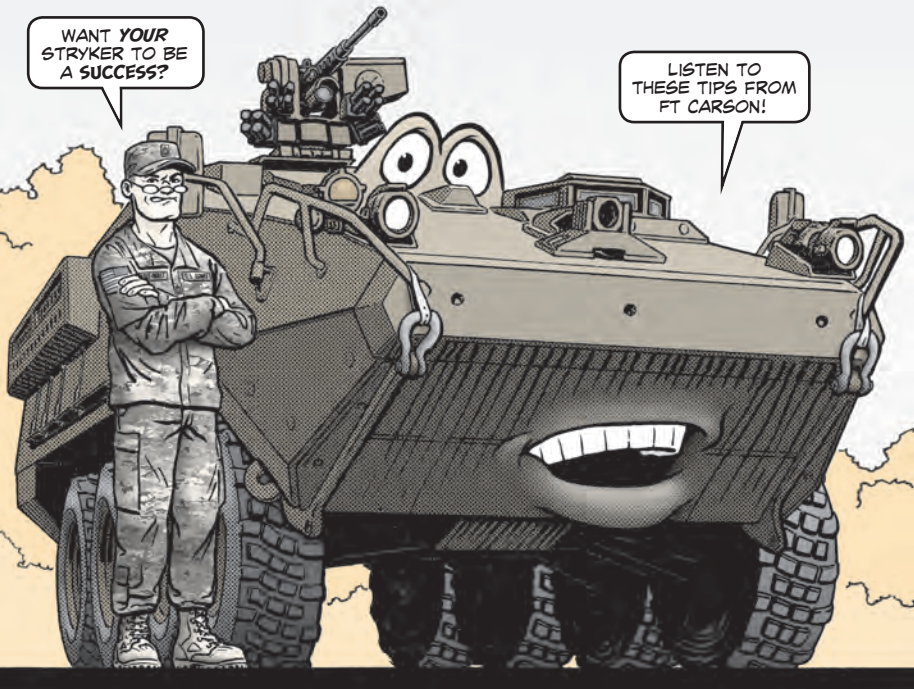

Dear Editor,
Follow these suggestions for Stryker success:

Don't reuse the copper seals for the wheel hubs.

Every time you drain and refill the hubs, install a **new seal**, NSN 5330-12-156-4524. Otherwise, the seal will probably leak and the hub could run low on fluid. Next thing you know, the hubs are damaged.



Replace seal and torque to 22-25 lb-ft when reinstalling drain plugs

Route the winch cable behind the wire cutter.

If the cable is in front of the cutter with the cutter upright, both the cable and cutter will wear against each other and one of them will fail. The cable needs to be behind the cutter with the cutter in the down position.

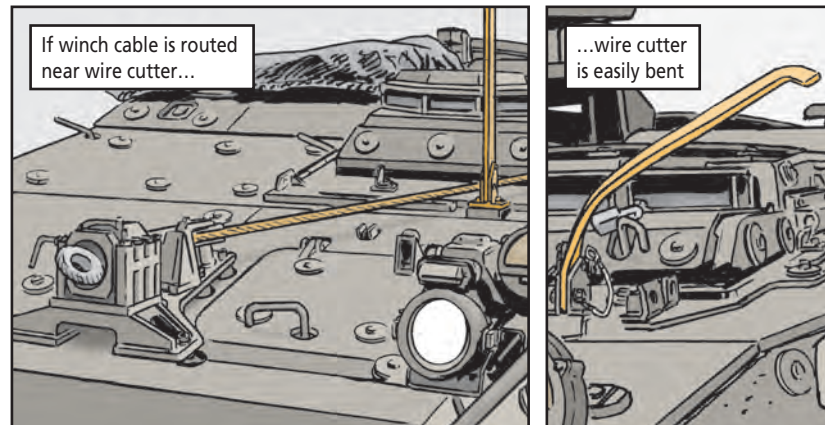

Cover and drain.

If you don't cover the Stryker in rainy areas, water runs down in the exhausts for both the engine and cooling module. Water collects in the hull and eventually causes electrical and corrosion problems. Clip the cover to the hold-down clamps to keep it secure.

Even if you do keep your Stryker covered, it's still a good idea to open all drain plugs monthly and let any water in the hull drain out. Make sure you use drip pans and dispose of the water according to your unit's SOP.

SGT Paul White
Ft Carson, CO

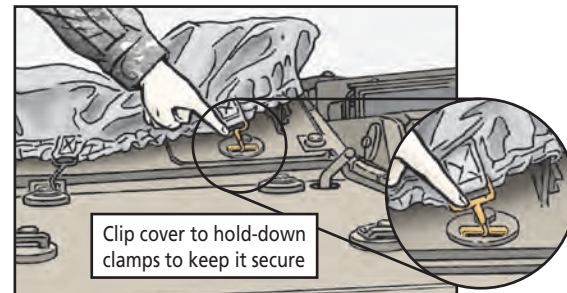

Editor's note: Excellent steps to Stryker success, Sergeant. Thanks.

Who Services the M242?

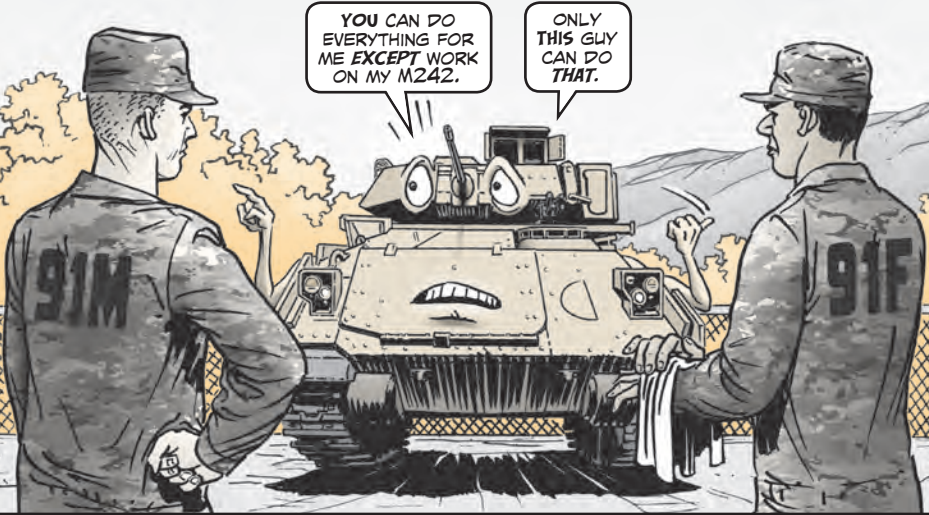

Dear Half-Mast,
Can the 91M turret and system mechanic work on the Bradley's M242 gun?

Mr. A.R.

THE SHORT ANSWER, SIR, IS NO. THE 91F SMALL ARMS REPAIRMAN IS THE **ONLY** MOS TRAINED TO WORK ON THE M242.

THE 91MS MAINTAIN THE BRADLEY TURRET, **NOT** THE WEAPON ITSELF.

THEIR JOB IS TO DIAGNOSE AND TROUBLE-SHOOT PROBLEMS AND DO MAINTENANCE ON THE TURRET AND FIRE CONTROL SYSTEM.

THE M242'S TM 9-1005-200-23&P HAS **NOT** YET BEEN UPDATED TO REFLECT THE NEW TWO-LEVEL MAINTENANCE FORMAT, BUT IT SOON WILL BE. IN THE MEANTIME, BRADLEY UNITS SHOULD NOTE IN THE -23&P THAT THE 91F SHOULD DO ALL ORGANIZATIONAL AND DIRECT SUPPORT MAINTENANCE ON THE M242.

IT'S **IMPORTANT** TO NOTE THAT CREW MEMBERS, REGARDLESS OF MOS, WHO GRADUATED FROM FT BENNING'S MASTER GUNNER SCHOOL AND ACQUIRED THE ADDITIONAL M242 SKILL IDENTIFIERS (AS1) OF THE COURSE ARE AUTHORIZED TO DO SOME MAINTENANCE TASKS AND SERVICES (-10 AND -20 LEVEL) ON THE M242.

MASTER GUNNERS CANT, HOWEVER, DO -30-LEVEL TASKS, SUCH AS WORKING ON THE FEEDER DRIVE OR WORM SHAFT ASSEMBLIES.

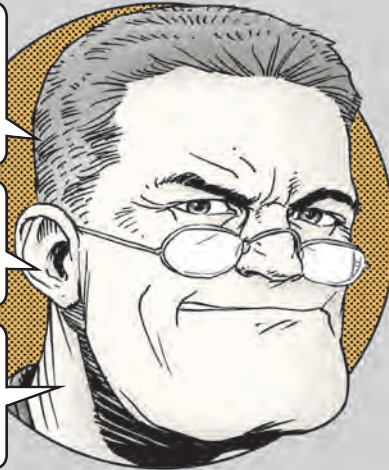

KEEP SAFE DURING FIRE MISSIONS!

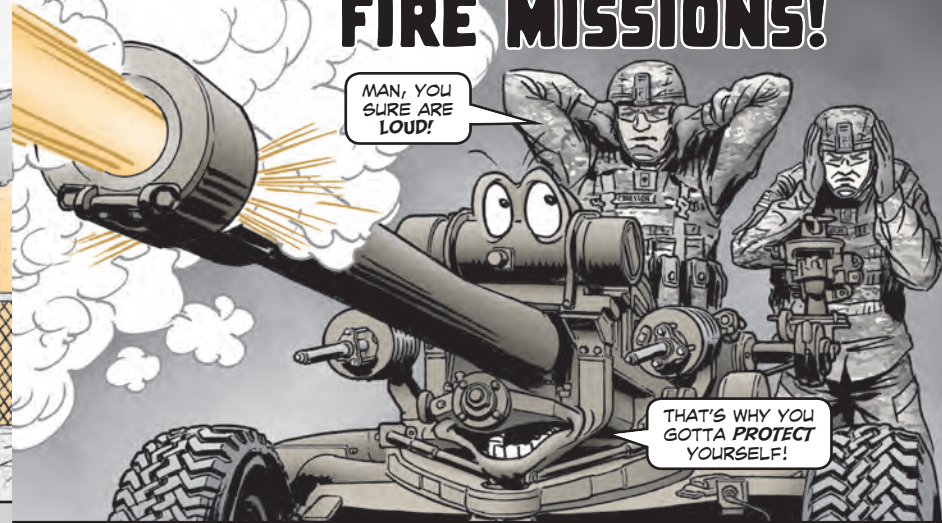

Crewmen, your M119A2/A3 towed howitzer makes a lot of noise and blast overpressure when it fires. That's why you have to protect yourself during fire missions.

Crews are required to keep track of the number of rounds that they fire in a 24-hour period using blast overpressure protection (BOP) points. The points are based on the lanyard used and the crew's position during firing. That keeps you from being exposed to too much noise and pressure from blasts that could leave you with hearing loss or injuries to your lungs and sinuses.

YOU SHOULD KNOW THAT THE BOP GUIDANCE SHOWN IN TM 9-1015-252-10 (SEP 10) REGARDING THE ALLOWED NUMBER OF ROUNDS (ANOR) A CREW CAN FIRE IN A 24-HOUR PERIOD IS **OUTDATED.**

HOWEVER, THE BOP GUIDANCE IN TM 9-1015-260-10 (NOV 17) IS **CORRECT.** THE BOP GUIDANCE IN THE **PREVIOUS** EDITION OF THE 260-10 IS **OUTDATED.**



For the latest ANOR information, check out attachment 1 in TACOM safety of use message 17-011. Access the message on the TACOM-Unique Logistics Support Applications (TULSA) website at:

<https://tulsa.tacom.army.mil/Safety/message.cfm?id=SOU17-011.html>

DON'T NEGLECT BATTERY PM!

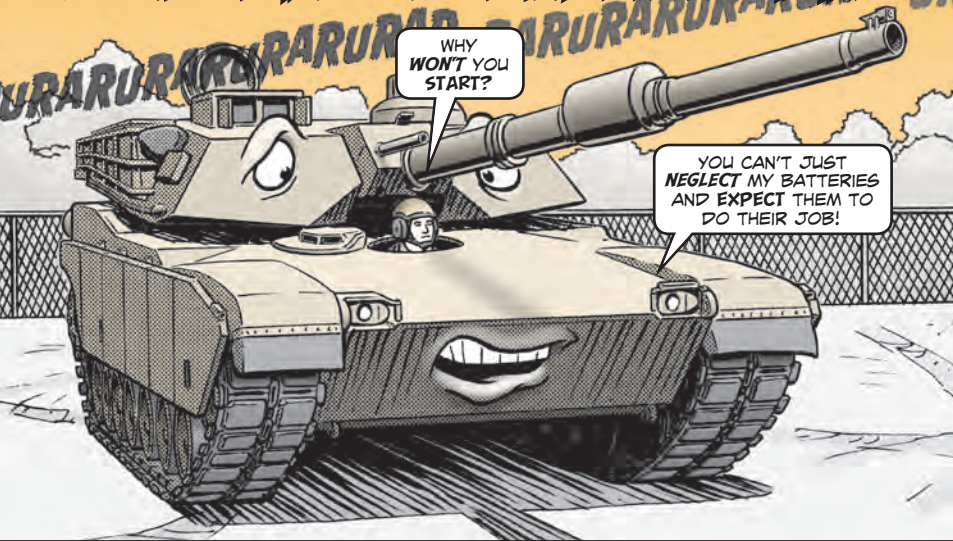

Dear Editor,

Some crewmen overlook the batteries when doing preventive maintenance on their M1-series tanks. That leads to corrosion and corrosion leads to a tank that won't start!

Make sure you clean the battery, battery cables, battery box and hold-down supports. Sure, that takes a little time and effort. But it's time and effort well spent.

Battery Clamps and Terminals

Use a battery terminal cleaner, NSN 5120-01-615-6464, to scrape away heavy corrosion from the battery clamps and terminals. Then clean with a solution of 1/2-pound of baking soda to one gallon of water. Get one pound of baking soda with NSN 6810-00-264-6618 or 100 pounds with NSN 6810-00-290-5574.

Use the battery terminal brush, NSN 5120-00-926-5175, for the best results.

After cleaning, inspect and replace any clamps that will no longer fit the battery posts or whose ends touch when the clamp nut is tightened.

Remove all batteries before cleaning

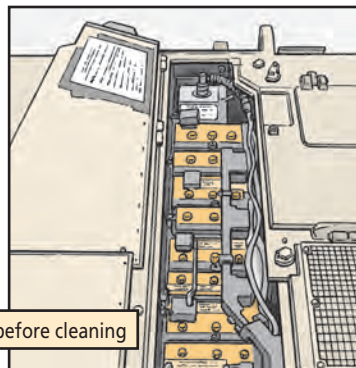

Battery Tray

Wash the battery tray with the baking soda solution. Rinse thoroughly and allow it to dry. Apply a 1/32- to 1/8- in thick coating of epoxy, NSN 8010-01-313-8702, or bituminous coating, NSN 8030-00-290-5141, to the box.

Wash dirty, corroded battery box with baking soda solution

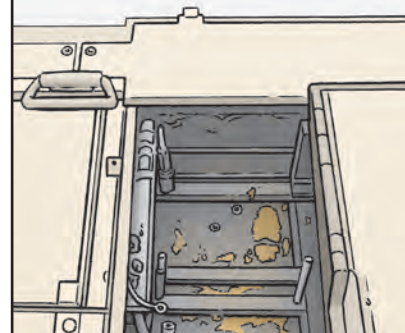

Reinstall the batteries after everything's dry. Before you reconnect the battery clamps, put a light coat of silicone compound on the tops and sides of each battery post. This special compound runs down around the battery post and terminal to completely seal out moisture.

Get a 3-oz tube with NSN 8040-01-331-7133 or a 1-pt can with NSN 8040-01-331-7134.

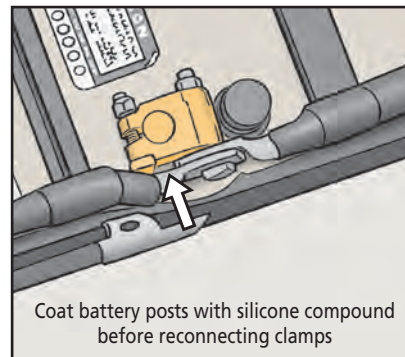

Battery Hold-downs

Clean as much corrosion, cracked paint and dirt as you can from the battery hold-downs with a wire brush, NSN 7290-00-291-5815. Then soak the hold-downs in the baking soda solution.

Give the hold-downs a good rinsing.

After they've dried, apply epoxy coating to each of the hold-downs. You can also use bituminous coating if the epoxy isn't available.

Clean battery hold-downs with wire brush

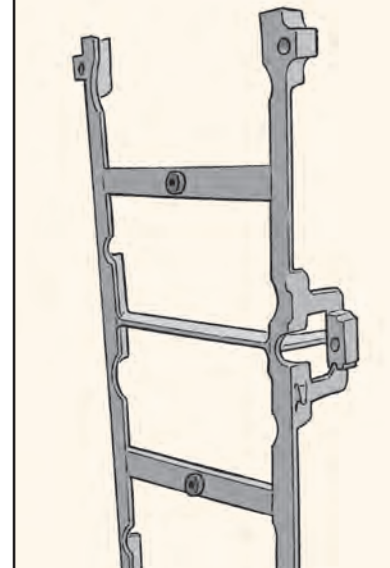

Doing all this will keep your tank's batteries ready to go and increase your unit's combat readiness.

CW3 Robert Bynum
Ft Stewart, GA

Editor's note: Crewmen should clean up with these tips. Thanks, Chief!

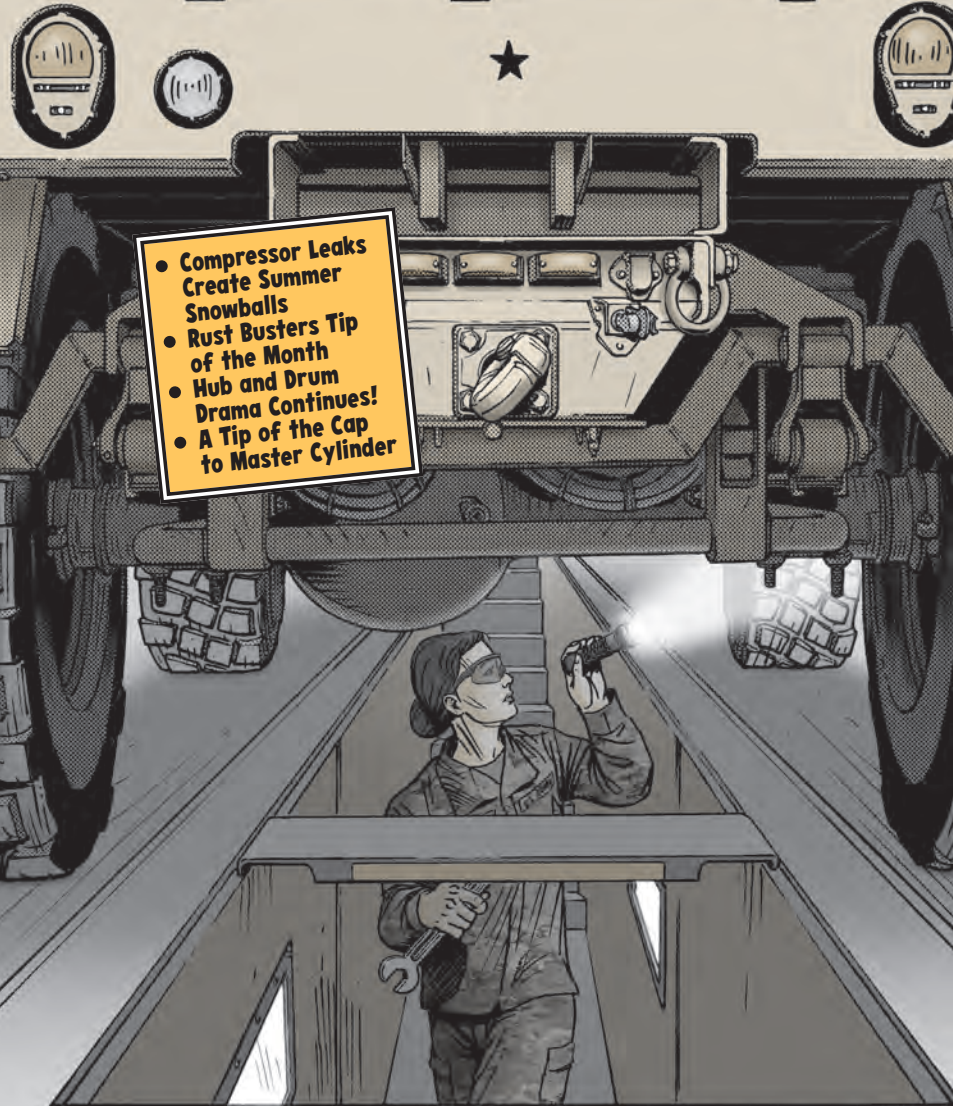

- Compressor Leaks Create Summer Snowballs
- Rust Busters Tip of the Month
- Hub and Drum Drama Continues!
- A Tip of the Cap to Master Cylinder

FMTVs...

COMPRESSOR LEAKS CREATE SUMMER SNOWBALLS

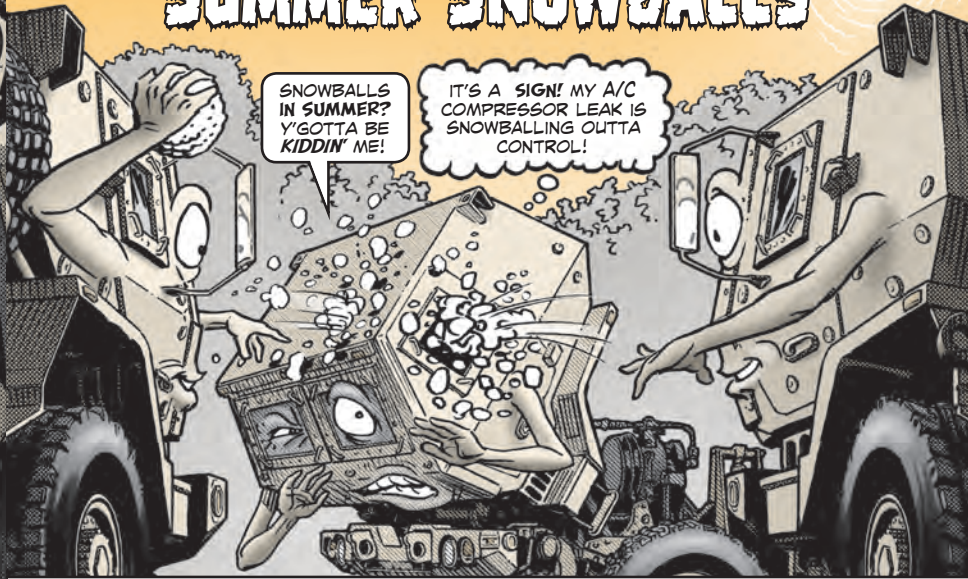

SNOWBALLS IN SUMMER? Y'GOTTA BE KIDDIN' ME!

IT'S A SIGN! MY A/C COMPRESSOR LEAK IS SNOWBALLING OUTTA CONTROL!

Summer heat means vehicle A/C gets a lot of use. In A/C-equipped FMTVs, this means operators and maintainers must pay special attention to the A/C air compressor for oil leaks that may snowball into bigger problems.

All air compressors run the risk of oil leaks. But in A/C-equipped FMTVs, it's especially risky because the oil leak usually signals a worsening problem. If left unattended, the leak can cause the A/C drive belt to seize and break.

If this happens, the drive belt can potentially fly into the engine fan (located right next to it) and cause serious damage. Now a simple oil leak has snowballed into an expensive and dangerous engine malfunction!

Prevent the snowball effect by keeping an eye on the A/C compressor. Identify oil leaks early. If they can't be fixed, replace the A/C compressor before the leak worsens and threatens the drive belt.

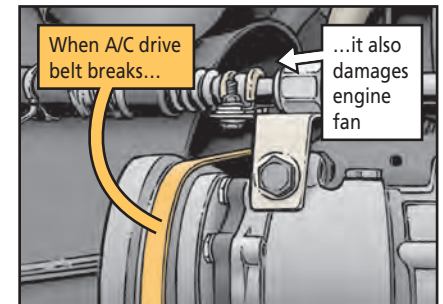

When A/C drive belt breaks...

...it also damages engine fan

RUST BUSTERS

TIP OF THE MONTH

FOLLOW REPORTING INSTRUCTIONS IN DA PAM 750-8; THE ARMY MAINTENANCE MANAGEMENT SYSTEMS (TAMMS) USER MANUAL (AUG 05); USING ONE OR MORE OF THE DESCRIPTIONS BELOW TO IDENTIFY CORROSION AND COATING ISSUES IN THE DEFICIENCIES AND SHORTCOMINGS SECTION OF THE 5988-E.

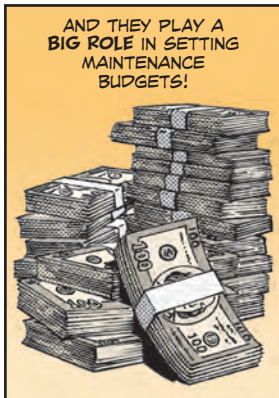
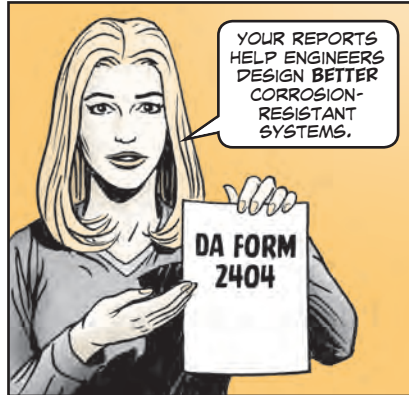

YOU INSPECT REGULARLY AND FIND CORROSION EARLY ENOUGH TO STOP IT.

GOOD WORK!

BUT

YOU'RE **NOT** DONE 'TIL YOU REPORT IT.

YOUR CORROSION REPORTS **CLOSE THE LOOP** BY HELPING ENGINEERS DESIGN BETTER CORROSION-RESISTANT SYSTEMS.

PROPER REPORTING ALSO PLAYS A BIG ROLE IN FUTURE MAINTENANCE BUDGETS.

TO REPORT CORROSION:
 USE DA FORM 2404, *EQUIPMENT INSPECTION AND MAINTENANCE WORKSHEET*.
 THE ONLINE VERSION IS DA FORM 5988-E, AVAILABLE IN THE GLOBAL COMBAT SUPPORT SYSTEM-ARMY (GCSS-A).

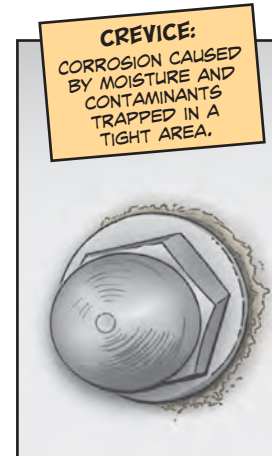
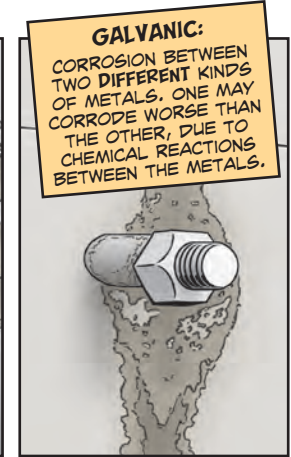

STATUS SECTION

IN THE STATUS SECTION OF EITHER DA FORM, CHOOSE THE DIAGONAL BACKSLASH SYMBOL (/) TO INDICATE AN ISSUE FIXED AT THE FIELD LEVEL. DOCUMENT THE FIX IN THE CORRECTIVE ACTION SECTION. FOR EXAMPLE, A TYPICAL ENTRY WOULD READ, "REPAIRED WITH SPOT PAINT."

ONLINE REPORTING

IF USING THE ONLINE DA FORM 5988-E IN GCSS-A, USE GCSS-A CAUSE CODE "170-CORRODED/RUSTED." YOUR EQUIPMENT REPAIR PART OR LOGISTICS AUTOMATION SPECIALISTS SHOULD HAVE ACCESS. THEY CAN TRANSCRIBE DATA FROM HARD COPIES INTO GCSS-A, SO ALL DIGITAL REPORTS ARE SEARCHABLE/RETRIEVABLE.

HUB AND DRUM DRAMA CONTINUES!

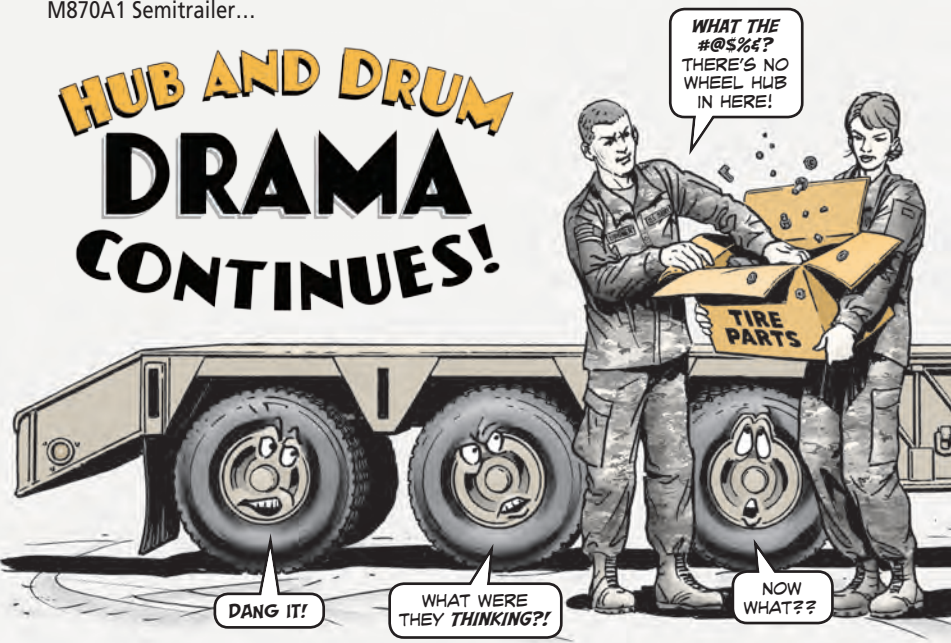

WHAT THE #@%&? THERE'S NO WHEEL HUB IN HERE!

DANG IT!

WHAT WERE THEY THINKING?!

NOW WHAT???

A WHILE BACK, A NEW SINGLE-PIECE WHEEL CAME OUT AS A REPLACEMENT FOR THE OLD SPLIT-RING RIM ON M870A1 SEMI-TRAILERS. IT WAS EXCITING NEWS (IN THE WHEEL WORLD, AT LEAST). BUT THE EXCITEMENT DIDN'T LAST LONG.

UNITS STARTED REPORTING PARTS MISSING FROM THE HUB AND DRUM CONVERSION KITS THAT WERE REQUIRED TO MOUNT THE NEW SINGLE-PIECE WHEELS. THESE HUB AND DRUM CONVERSION KITS, NSN 2530-01-643-7190, WERE MISSING THE WHOLE HUB ASSEMBLY!

Drama Unfolds



DLA LAUNCHED AN INVESTIGATION, AND THE STORY TOOK A DRAMATIC TURN.

DLA FOUND THAT THE CONTRACTOR TRIED TO PIECE TOGETHER THE HUB ASSEMBLY INSTEAD OF PURCHASING IT AS REQUIRED FROM THE SOURCE.

BUT THE CONTRACTOR COULDN'T PROVIDE THE ACTUAL HUBS, WHICH MADE THE CONVERSION KITS USELESS. WITHOUT THE CONVERSION KIT, THE M870A1 CAN'T BE MOUNTED WITH THE NEW SINGLE-PIECE WHEELS THAT ARE MEANT TO REPLACE THE SPLIT RIMS.

NEW KITS THAT INCLUDE THE HUB SHOULD NOW BE AVAILABLE.

Now What?

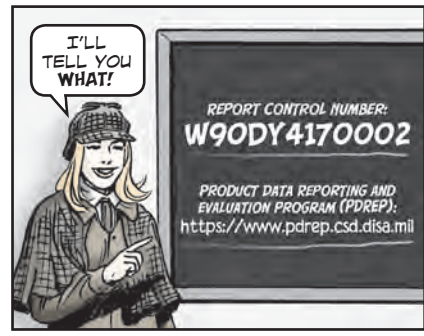

I'LL TELL YOU WHAT!

IF YOUR UNIT HAS ANY OF THESE CONVERSION KITS THAT ARE MISSING THE HUB, SEND A PQDR SAYING YOU'RE REPORTING DUE TO AN ALERT NOTIFICATION.

USE REPORT CONTROL NUMBER W90DY4170002 AND FILE THE PQDR THROUGH THE PRODUCT DATA REPORTING AND EVALUATION PROGRAM (PDREP): <https://www.pdrep.csd.disa.mil>

IN THE MEANTIME, **DO NOT** TRASH THE KITS. YOU'LL NEED TO HOLD ONTO THOSE UNTIL YOUR UNIT IS GIVEN DISPOSITION INSTRUCTIONS FROM THE PQDR.

M1101, M1102 Light Tactical Trailers...

A TIP OF THE CAP TO MASTER CYLINDER



THE RIGHT CAP CAN PREVENT USE OF THE WRONG BRAKE FLUID.

Need a new cap for the brake master cylinder on your M1101 or M1102 light tactical trailer? Don't use NSN 5340-01-549-5983, which is shown as Item 7 in Fig 8 of TM 9-2330-392-13&P (Dec 12).

That old cap is marked to use commercial DOT fluids in the cylinder when you're supposed to use the MIL-B-46176 brake fluid called out in the TM.

Order a new, correctly marked cap with NSN 2590-01-664-6765. And make a note until the TM is updated.

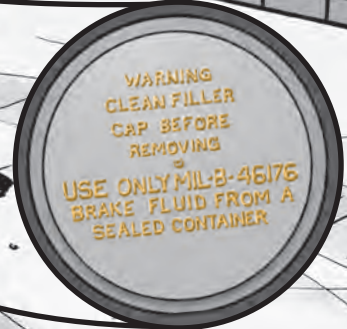

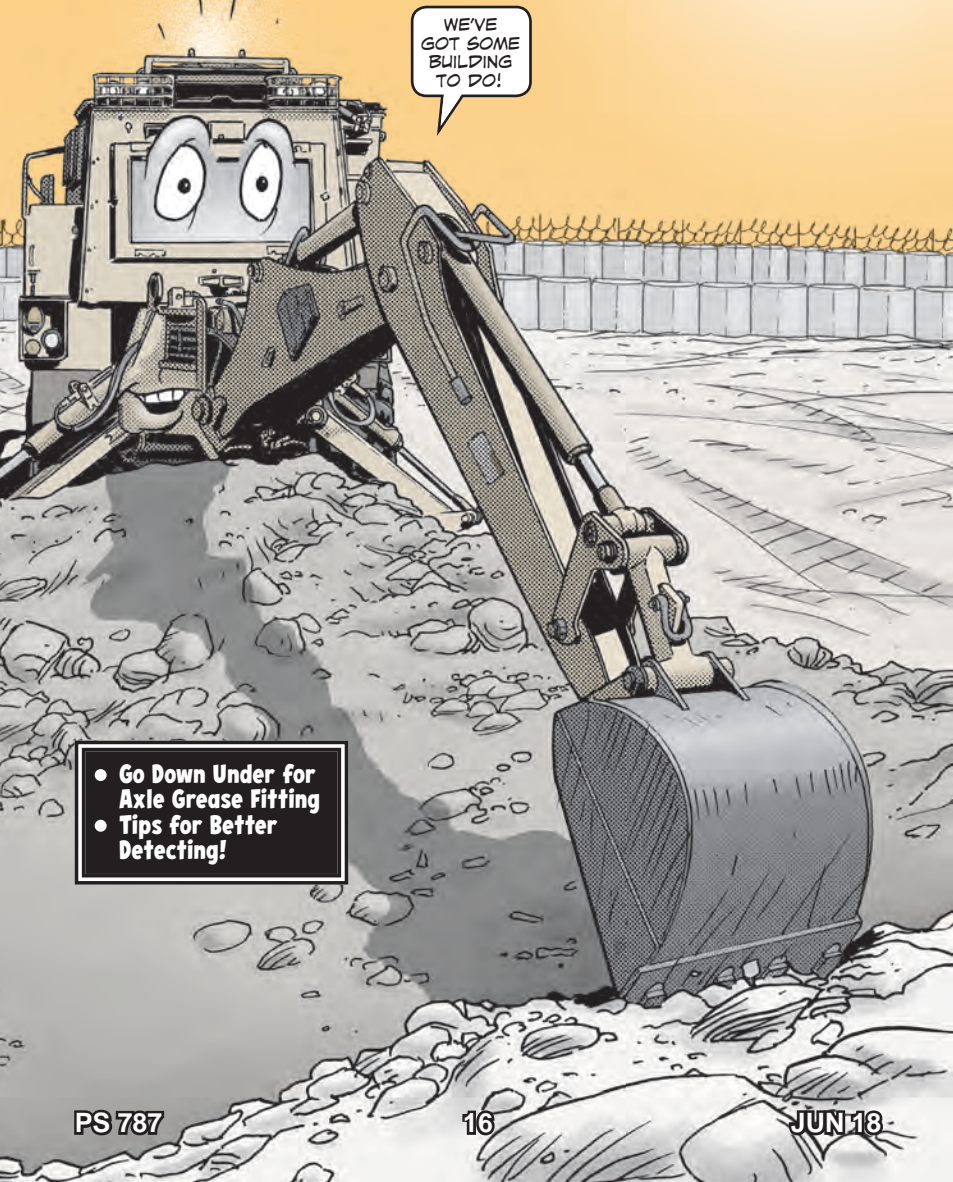

WE'VE GOT SOME BUILDING TO DO!

- Go Down Under for Axle Grease Fitting
- Tips for Better Detecting!

HMEE-1...

GO DOWN UNDER FOR AXLE GREASE FITTING!

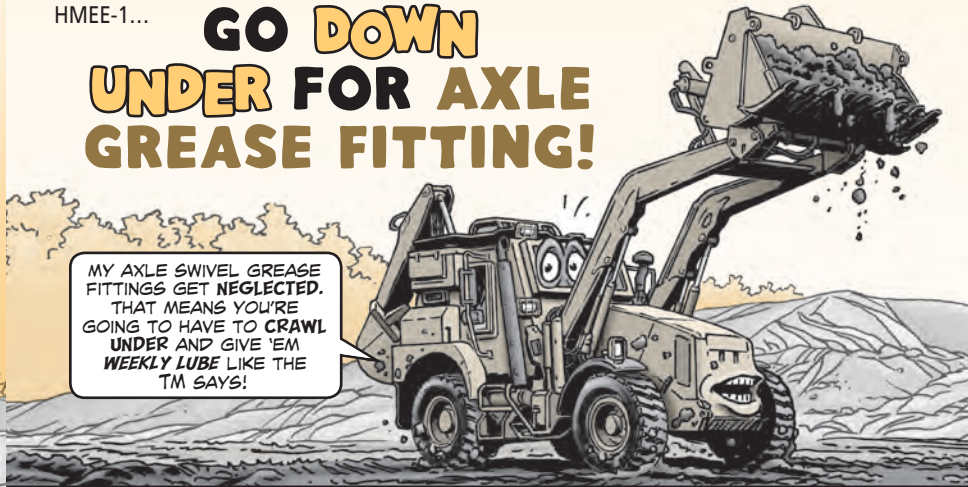

MY AXLE SWIVEL GREASE FITTINGS GET NEGLECTED. THAT MEANS YOU'RE GOING TO HAVE TO CRAWL UNDER AND GIVE 'EM WEEKLY LUBE LIKE THE TM SAYS!

OPERATORS, ONE OF THE GREASE FITTINGS ON THE HMEE-1 EXCAVATOR GETS OVERLOOKED A LOT. IT'S THE AXLE SWIVEL FITTING UNDER THE VEHICLE. YOU'LL FIND ONE NEXT TO EACH OF THE WHEEL ASSEMBLIES' BRAKE CALIPER AND DISC.

THE PMCS TABLES CALL THIS AN AXLE SWIVEL FITTING, WHILE THE PARTS MANUAL LISTS IT AS A TRUNNION FITTING. EITHER WAY, THE FITTING NEEDS TO BE LUBED WEEKLY.

AND THAT MEANS YOU HAVE TO CRAWL UNDER THE VEHICLE WITH A GREASE GUN TO DO THE JOB.



THE RECESSED AREA WHERE THE FITTING IS MOUNTED GETS CLOGGED UP WITH MUD AND DIRT, SO THE FITTING IS EASY TO MISS. PRY OUT ANY CRUD AND WIPE THE FITTING WITH A CLEAN RAG. THEN GIVE IT FOUR TO FIVE SHOTS OF GREASE.

WHEN YOU'RE FINISHED, MAKE SURE TO PUT THE RED PLASTIC CAP BACK ON THE FITTING TO KEEP OUT DIRT.

IF IT'S MISSING, ORDER A PACKAGE OF 10 NEW CAPS WITH NPN 4730-99-142-5123.

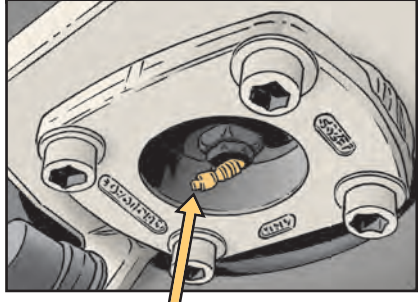

Clean recessed area and give fitting four to five shots of grease

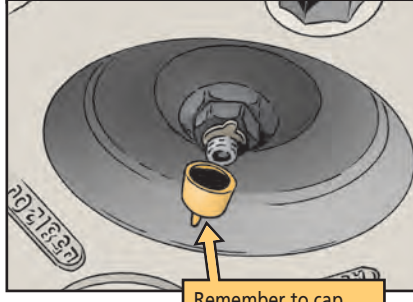

Remember to cap fitting when finished

DON'T FORGET THE AXLE SWIVEL FITTINGS UP TOP NEED THE SAME TREATMENT.

HELLO, I'M STAFF SERGEANT MARVIN HAMLER AND HERE ARE A FEW...

TIPS FOR BETTER DETECTING!

WE SHARE THESE TIPS WITH OUR STUDENTS AT THE COMBAT ENGINEERING SCHOOL AT FORT LEONARD WOOD.

Before use, prepare and calibrate the detector so it can adapt to the soil it will be detecting in. That tells the mine detector what minerals are in the soil and helps prevent false readings. If the terrain changes, calibrate again. That way you don't waste time trying to find a non-existent mine.

DID YOU MAKE SURE I'M CALIBRATED FOR THIS SOIL?

Remember LOSS:

- L = lane coverage
- O = operator stance
- S = sweep speed
- S = search head position

Keep the detector search head parallel to the ground and no more than two inches from the ground. That's especially important on uneven ground.

If the head is at an angle, it can give false ground penetrating radar (GPR) readings. That could cause you to miss a mine. Try to sweep one meter per second across a 1-meter lane. If you sweep wider or faster, you'll have less control and more fatigue.

Keep head parallel to ground and no more than 2 inches from ground



Beware of RF. Electrical interference can hurt detectors' detecting ability. Don't carry a cell phone or radio. Stay at least two meters away from anyone else operating a mine detector. Always be aware of where other Soldiers are sweeping. Stay at least 25 meters away from mounted systems that block RF to IEDs and at least 10 meters from manpack systems that do.

r-r-r-ring

OH, C'MON! YOU KNOW PHONES HURT MY DETECTING!

Take a break. Rotate with another operator every 20 minutes to prevent fatigue that could cause you to miss a signal.

GEE, TAKE A BREAK! YOU'RE NO GOOD TO ME WHEN YOU'RE THIS TIRED.

Editor's note: A gold mine of mine detector tips! Thanks, Sergeant.

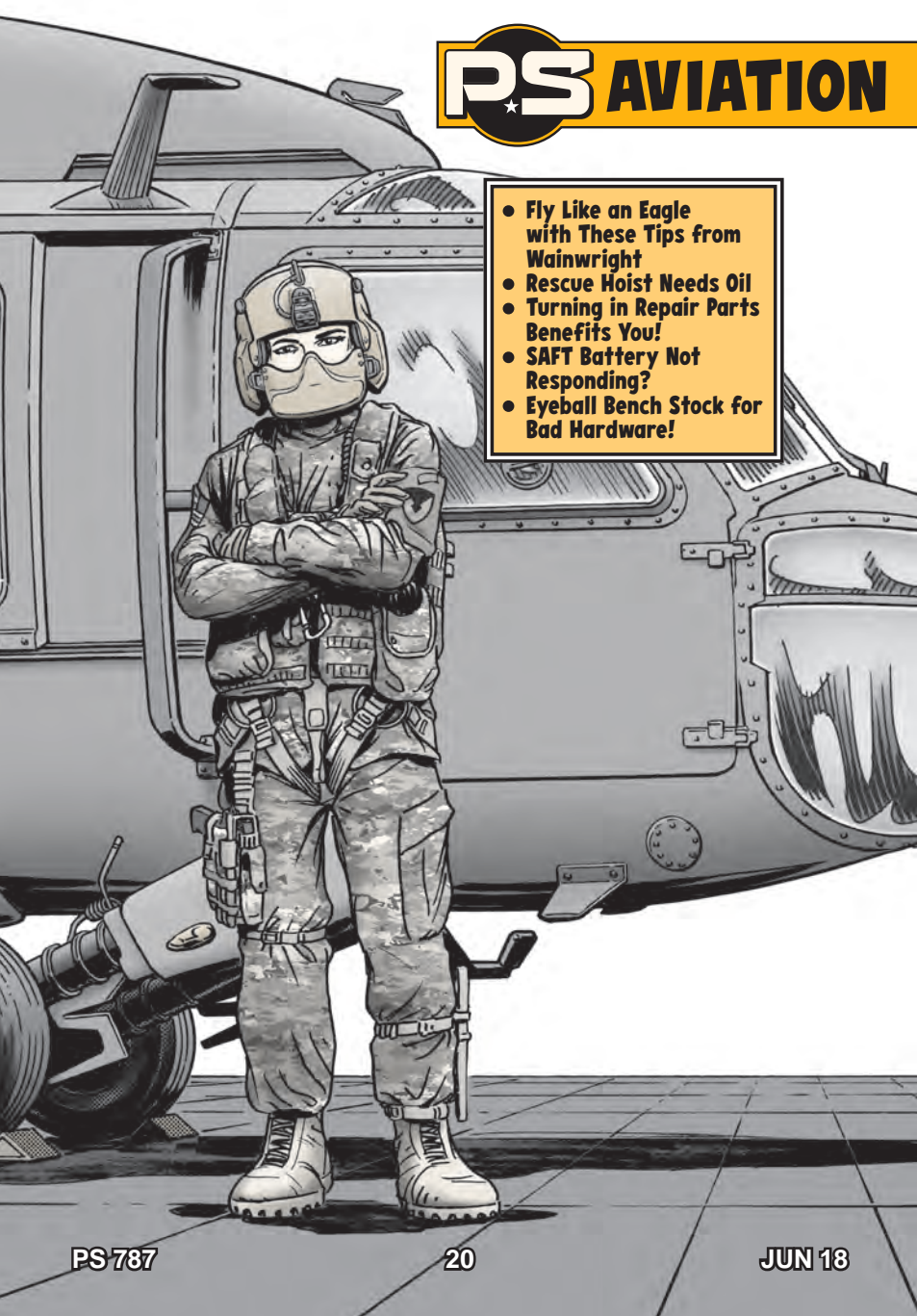

- Fly Like an Eagle with These Tips from Wainwright
- Rescue Hoist Needs Oil
- Turning in Repair Parts Benefits You!
- SAFT Battery Not Responding?
- Eyeball Bench Stock for Bad Hardware!

Fly Like an Eagle with These Tips from Wainwright



Dear Editor,

Through our experience keeping Gray Eagle UAVs flying at Ft Wainwright, we offer these tips:

When checking for FOD, look in the lower aft cowl. Debris tends to collect by the mounting bolts. Also be on the lookout for water and oil in the cowl. They can affect the material that makes up the Gray Eagle's body. The lubes and coolant glow under black light, making them easier to spot.

Keep the door to the ground control station closed. Otherwise, the ECU has trouble cooling the equipment. Then it overheats and shuts down. The door also blocks out RF interference and keeps the enemy from spotting the lights inside.

Easy does it with the ground control station headsets. Rough handling damages their padding and microphones. If you're not using the microphones, hang them gently on their hooks inside the station. Never toss them. It costs \$2,000 to replace them.

Remember to check lower aft cowl for FOD and oil and water

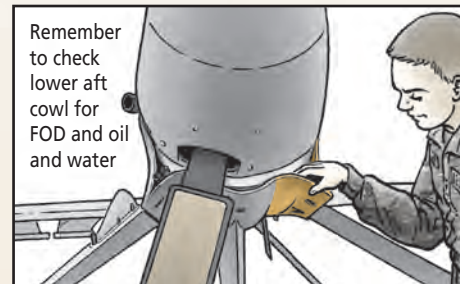

Keep ground control station door closed to help ECU cool equipment

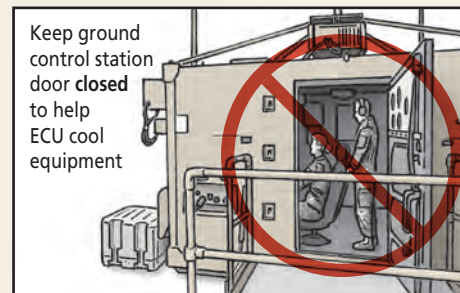

SGT Nicholas Parade
SGT Joseph Klomp
Ft Wainwright, AK

Editor's note: Thanks for helping Gray Eagles fly even higher.

RESCUE HOIST NEEDS OIL

AHH... THAT'S BETTER! MY HOIST MOTOR DIDN'T HAVE ENOUGH OIL AND IT GOT HOT!

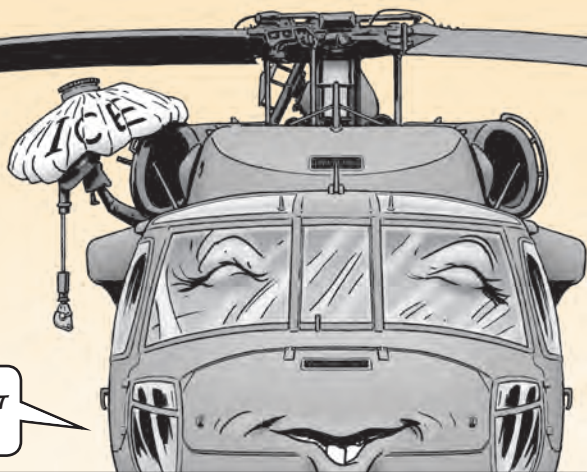

Mechanics, quite a few Black Hawk external rescue hoist motors are burning up. Hoists turned in to supply were torn down and analyzed. Many did not have sufficient oil. A hoist motor has no oil, but there must be enough oil in the drum assembly to prevent additional friction that can cause premature motor failure.

You're required to check the oil level every six months. And make sure you keep up with pre-flight inspections of the hoist to include visual checks of the end covers for oil leaks, like it says in WP 1222 00 of TM 1520-280-23&P. An empty reservoir will hold 17 ounces of oil.

Since adding oil takes time, you'll need a little patience when doing the job. Filling too fast can cause a vacuum that requires some settling time before more oil can be added.

ALWAYS PRE-FLIGHT YOUR AIRCRAFT'S HOIST AND MAKE SURE YOU VISUALLY CHECK THE END COVERS FOR OIL LEAKS.

EVERY SIX MONTHS, CHECK THE OIL LEVEL. BURNT-OUT HOIST MOTORS ARE AVOIDABLE.



CHECKING THE OIL ENSURES YOU'LL HAVE NO HITCHES WITH THE HOIST WHEN IT'S TIME TO AIRLIFT PATIENTS!

TURNING IN REPAIR PARTS BENEFITS YOU!

HEY, DO YOU GUYS HAVE ANY COMBO PAKS?

WE'RE JUST ABOUT OUT OVER HERE!

YEAH, WE JUST GOT IN A BUNCH OF UNSERVICEABLES. WE'LL HAVE 'EM REPAIRED AND SENT OUT SHORTLY!

MECHANICS, GETTING PARTS FROM THE SUPPLY SYSTEM WILL **ONLY** WORK IF YOU **TURN IN UNSERVICEABLES** YOU HAVE LAYING AROUND THE SHOP AREA.

Turn in all unserviceable IAFS for repair

SO GET ON BOARD THE RETURN TRAIN AND TURN IN UNSERVICEABLE **INTERNAL AUXILIARY FUEL SYSTEM (IAFS) COMBO PAKS**. NSN 1660-01-519-4248 (PN HMO25-600-11).

THE COMBO PAKS ARE A **KEY SOURCE** OF SUPPLY FOR REPAIR PROGRAMS. THOSE PROGRAMS RELY ON RETROGRADES SO REPAIRED PARTS CAN **RESTOCK** THE SUPPLY SYSTEM.

IF YOU HAVE IAFS COMBO PAKS THAT NEED REPAIR, SEND THEM TO:
Corpus Christi Army Depot
Plant 7015/RIC B52
Corpus Christi, TX 78419

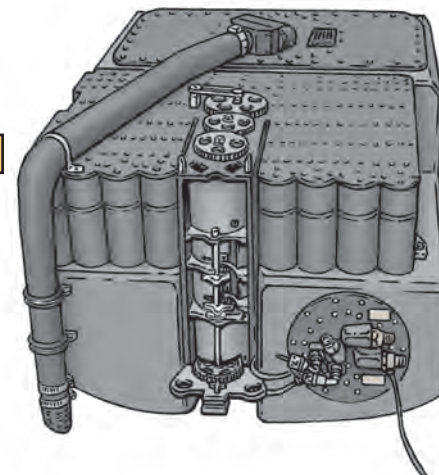

GOT QUESTIONS?

CONTACT AMCOM'S MICHAEL SHARP AT DSN 897-4276, (256) 313-4276 OR EMAIL: michael.b.sharp1.civ@mail.mil

SAFT BATTERY NOT RESPONDING?

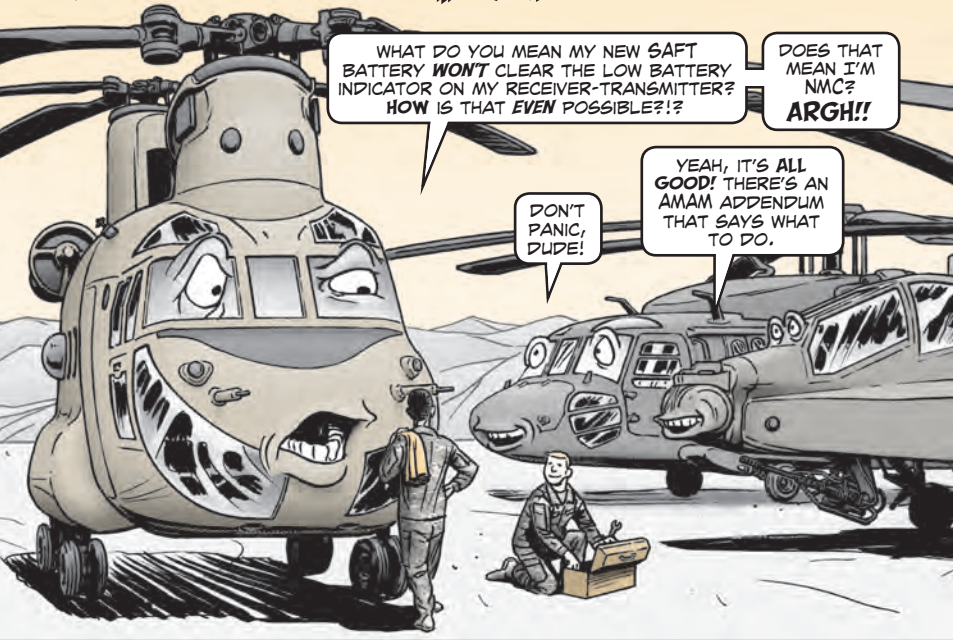

WHAT DO YOU MEAN MY NEW SAFT BATTERY *WON'T* CLEAR THE LOW BATTERY INDICATOR ON MY RECEIVER-TRANSMITTER? HOW IS THAT *EVEN* POSSIBLE?!

DOES THAT MEAN I'M NMC? ARGH!!

DON'T PANIC, DUDE!

YEAH, IT'S ALL GOOD! THERE'S AN AMAM APPENDUM THAT SAYS WHAT TO DO.

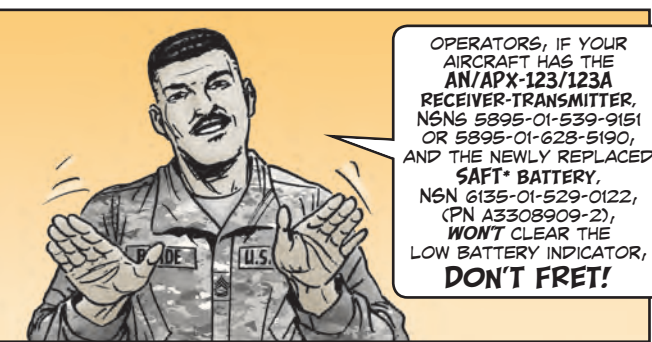

OPERATORS, IF YOUR AIRCRAFT HAS THE AN/APX-123/123A RECEIVER-TRANSMITTER, NSNG 5895-01-539-9151 OR 5895-01-628-5190, AND THE NEWLY REPLACED SAFT* BATTERY, NSN 6135-01-529-0122, (PN A3308909-2), **WON'T** CLEAR THE LOW BATTERY INDICATOR, **DON'T FRET!**

APPENDUM 1 TO AVIATION MAINTENANCE ACTION MESSAGE (AMAM) GEN-16-AMAM-04 IS THE PLACE TO GO.

IT PROVIDES ADDITIONAL INSTRUCTIONS THAT ADDRESS THE LOW BATTERY INDICATOR PROBLEM.

*SAFT batteries are identified by a black label with white lettering

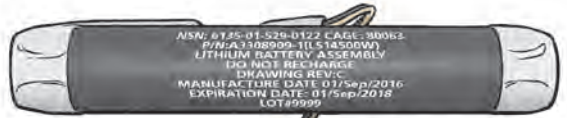

YOU NEED TO CHECK OUT THE NOTES AND STEPS 11-13 ON PAGES 2 AND 3. AFTER INSTALLING THE BATTERY:

11. Re-install the cover with the four captive screws.
 NOTE: The red LOW BTRY LED will stay lit after replacing the battery cover. To clear the indicator, briefly press the ZEROIZE button.
 NOTE: Briefly pressing the ZEROIZE button initiates a built in test (BIT) similar to the Power-Up BIT (PUBIT). It also zeroes the crypto keys, if loaded.
12. Clear the red LOW BTRY light by briefly pressing the ZEROIZE button on the front panel. It may be necessary to press the ZEROIZE button several times at one minute intervals between each cycle to burn off passivation from a stored battery. If you're not successful after four cycles, replace the battery assembly again by repeating steps 6-13.
 NOTE: If the LOW BTRY light doesn't go out, the battery may not be installed correctly or the battery voltage may be below the low battery light threshold.
13. Make sure the LOW BTRY light goes out after completion of the BIT.
 NOTE: Aircraft with the AN/APX-123A must wait 30 seconds after briefly pressing the ZEROIZE button to ensure the LOW BTRY light remains off.

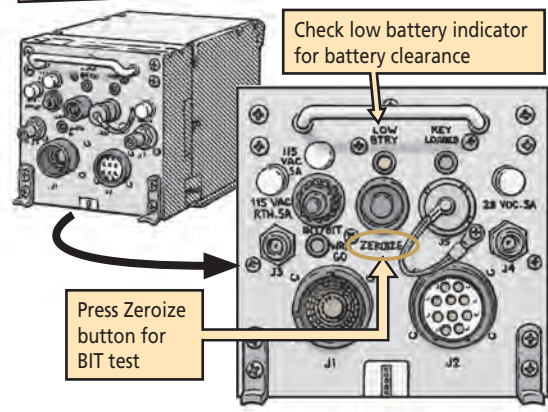

DOWNLOAD GEN-16-AMAM-04 AT:
https://asmprd.redstone.army.mil/FileHandler.ashx?file=UFI_064f9a4a-0ffe-4d4e-b615-be1138e396fb

FOR A COPY OF THE APPENDUM, GO TO:
https://asmprd.redstone.army.mil/FileHandler.ashx?file=UFI_bb87e852-e835-4e55-b74b-4ff0b6605e79

YOU SHOULD **NEVER** ATTEMPT TO CHECK THE VOLTAGE OF THE BATTERY BECAUSE THE FUSE IS SENSITIVE AND MAY BLOW. THE TRANSPONDER CAN TEST THE BATTERY VOLTAGE DURING THE ABBREVIATED PUBIT. JUST BRIEFLY PRESS THE ZEROIZE BUTTON. IT WILL INDICATE THE RESULT USING THE LOW BTRY LIGHT.

IF YOUR BATTERY **WON'T** CLEAR THE LOW BTRY INDICATOR, EVEN AFTER FOLLOWING THIS PROCEDURE, SUBMIT A PRODUCT QUALITY DEFICIENCY REPORT (PQDR) TO :
<https://www.pdrep.csd.disa.mil>

IF YOU **DON'T** HAVE A PDREP USER ID, SUBMIT THE PQDR THROUGH THE EZ PDR LOGIN TAB.

TO GET A USER ID, SUBMIT A SYSTEMS ACCESS REQUEST (SAR) TO:

https://www.pdrep.csd.disa.mil/pdrep_files/accessforms/useraccess.htm

NEED HELP WITH THE CECOM PQDR PROCESS? CONTACT THE CECOM PQDR TEAM AT:
usarmy.apg.cecom.mbx.irc-leo-b16-pqdr-support-team@mail.mil

OH NO! SOMEONE'S LOOKING TO CHECK OUR QUALITY!

AND OUR CONDITION!

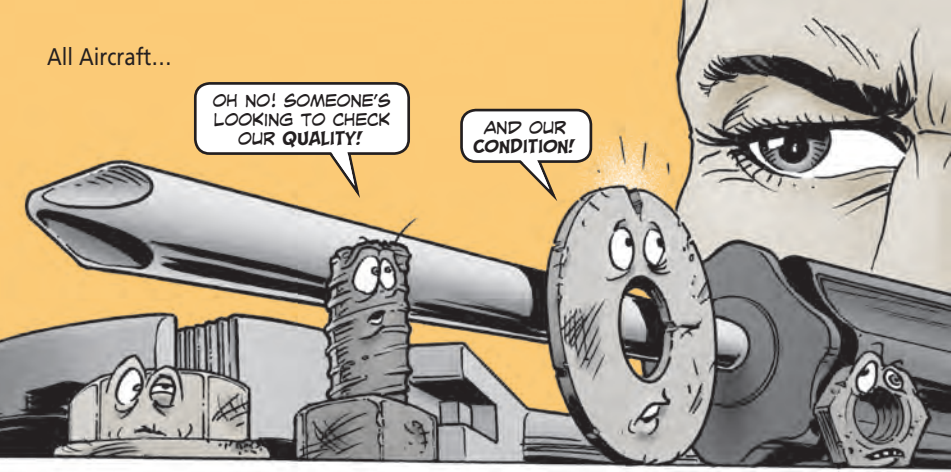

EYEBALL BENCH STOCK FOR *BAD* HARDWARE!

MECHANICS, AVIATION MAINTENANCE OFTEN INVOLVES THE USE OF COMMON HARDWARE SUCH AS NUTS, BOLTS AND WASHERS.

BUT WHEN YOU USE *BENCH STOCK*, IT'S A GOOD IDEA TO INSPECT ITS *QUALITY AND CONDITION*.

BUYING HARDWARE IN BULK FOR BENCH STOCK IS A COMMON PRACTICE. SOMETIMES WE JUST ASSUME EVERYTHING IS OK. BUT THERE HAVE BEEN INSTANCES WHERE COMMON HARDWARE *HASN'T* MET MILITARY SPECIFICATIONS.



MAKE A PRACTICE OF INSPECTING COMMON HARDWARE IN YOUR BENCH STOCK.

IF YOU FIND *PROBLEMS* WITH AN ITEM...
...PULL TOGETHER ALL THE MAINTENANCE INFORMATION YOU CAN FROM THE PACKAGING, INCLUDING *CONTRACT PURCHASING INFORMATION* AND *VENDOR CAGE*.

See the difference between a good and bad nut

GOOD NUT



BAD NUT



Only use bench stock that meets specifications

USE THAT INFORMATION TO COMPLETE A SUPPLY DISCREPANCY REPORT (SDR) OR QUALITY DEFICIENCY REPORT (QDR).

THAT HELPS IDENTIFY VENDORS WHO *AREN'T* PRODUCING HARDWARE TO STANDARD AND COULD PREVENT AN AIRCRAFT INCIDENT.

PM Mission to Mars

WOW! WOULD JA LOOK AT THAT VIEW!



The year is 2025. A series of missions have sent robot rovers to Mars. But all have fallen strangely **silent**. At last, a manned crew is sent to **solve** the mystery...

LET'S GET TO THE LAB.

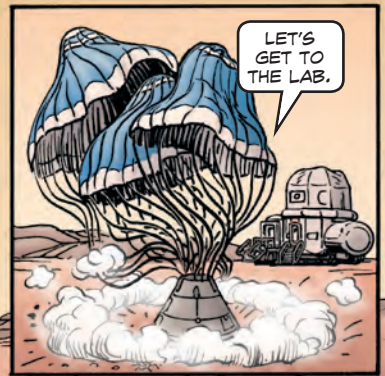

IT'S TIME WE FIGURED OUT WHAT'S GOING ON HERE.



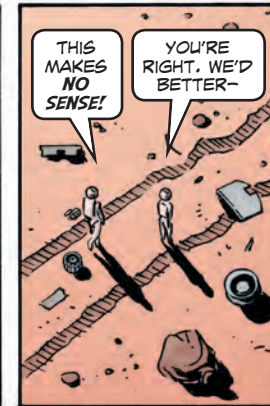
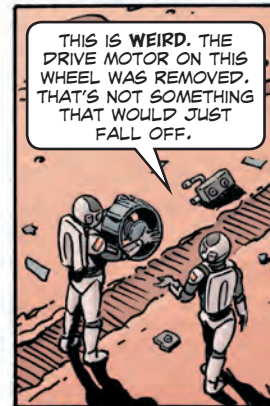
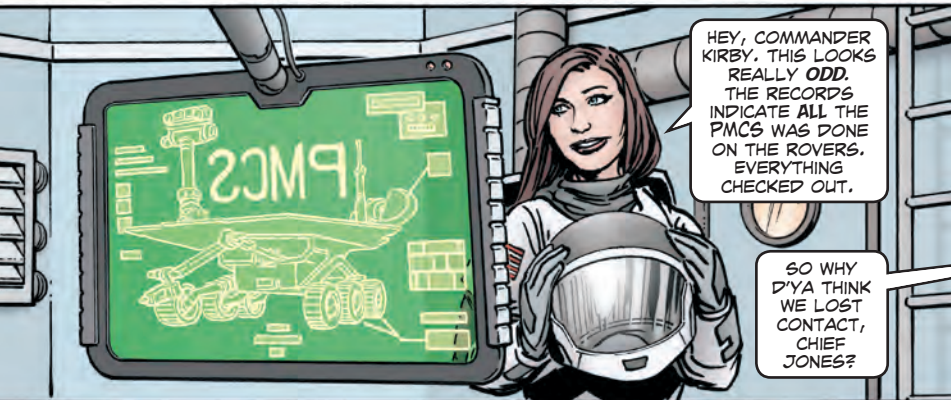
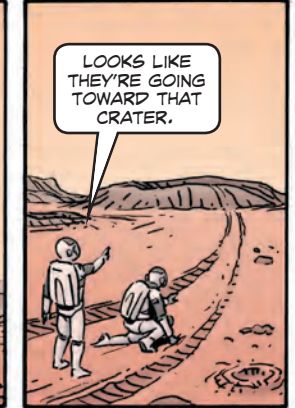
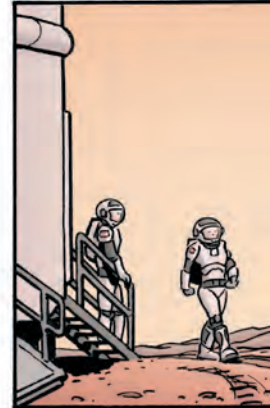
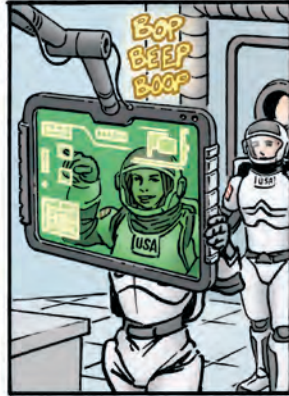
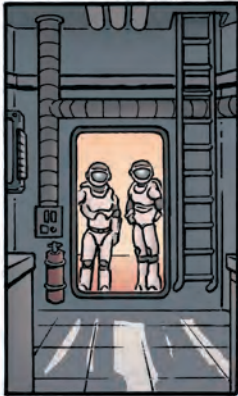
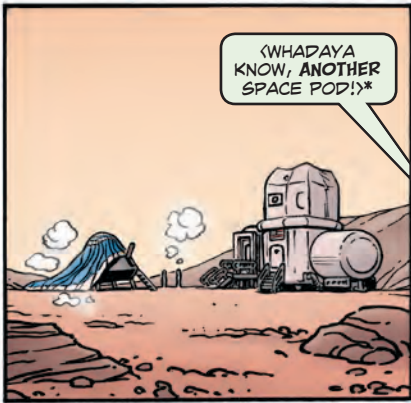

*◀TRANSLATED FROM THE ALIEN▶

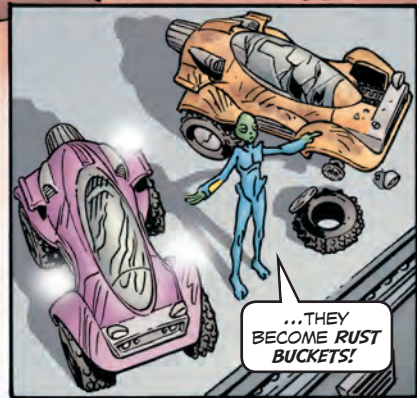
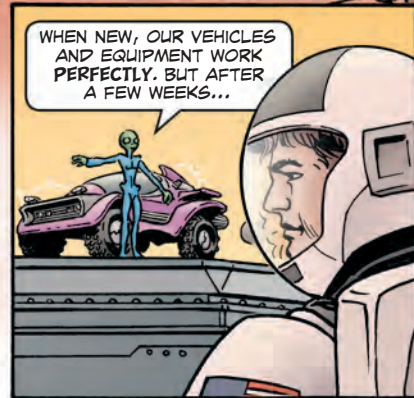
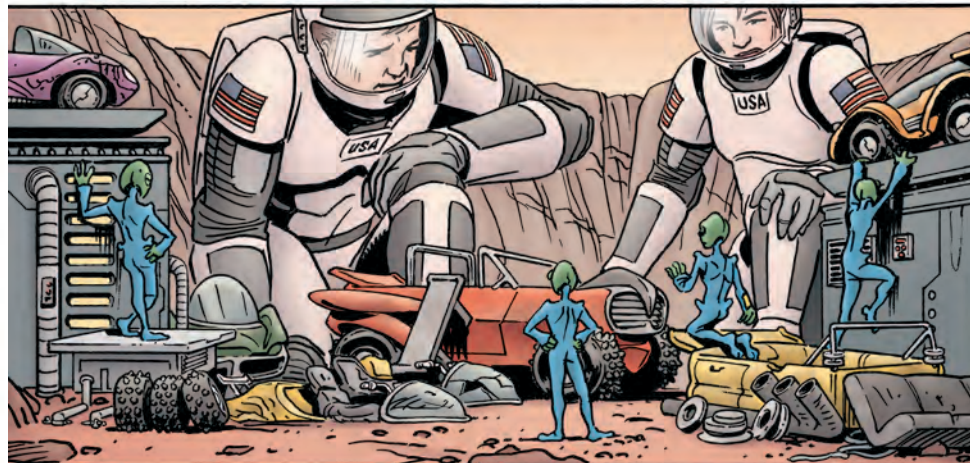
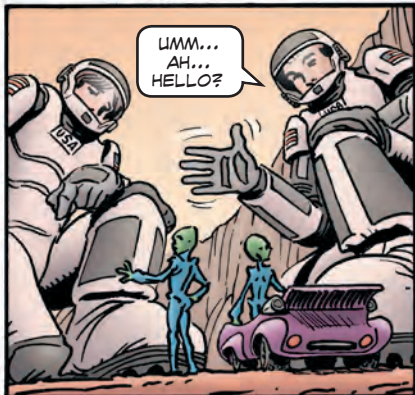
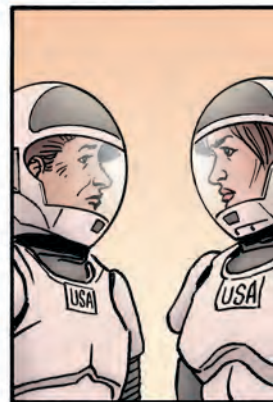
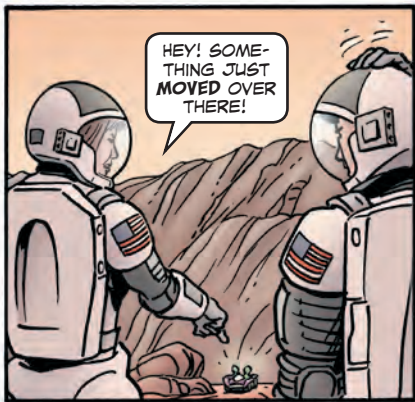

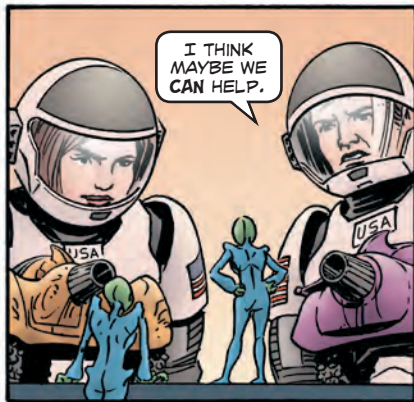

I THINK
MAYBE WE
CAN HELP.

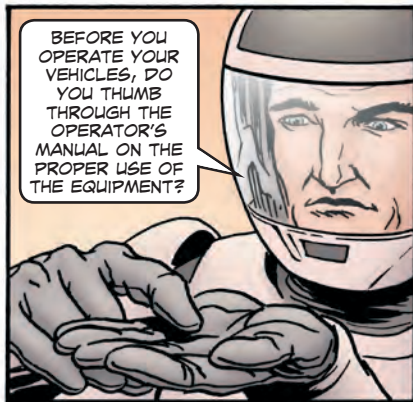

BEFORE YOU
OPERATE YOUR
VEHICLES, DO
YOU THUMB
THROUGH THE
OPERATOR'S
MANUAL ON THE
PROPER USE OF
THE EQUIPMENT?



YOU HAVE A
QUESTION?



UMMM...
WHAT'S A
THUMB?

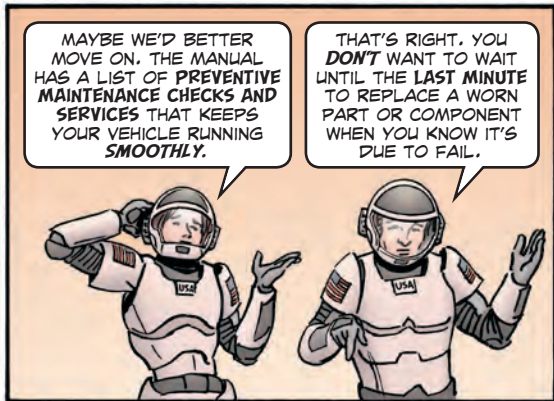

MAYBE WE'D BETTER
MOVE ON. THE MANUAL
HAS A LIST OF PREVENTIVE
MAINTENANCE CHECKS AND
SERVICES THAT KEEPS
YOUR VEHICLE RUNNING
SMOOTHLY.

THAT'S RIGHT. YOU
DON'T WANT TO WAIT
UNTIL THE LAST MINUTE
TO REPLACE A WORN
PART OR COMPONENT
WHEN YOU KNOW IT'S
DUE TO FAIL.



WHAT'S A
MINUTE?



I'M TRYING TO
SAY YOU NEED TO
TAKE CARE OF
EQUIPMENT SO IT
DOESN'T BREAK!!!



THE SAME GOES FOR
YOUR SPACE SHIP OR
FLYING SAUCER, OR
WHATEVER, IN CASE
YOU WANT TO GET
OFF THIS PLANET.



UGH!
LEAVE OUR
PLANET?
DUDE, WE
LOVE IT
HERE!

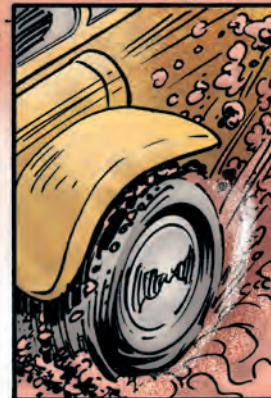

SIGH...

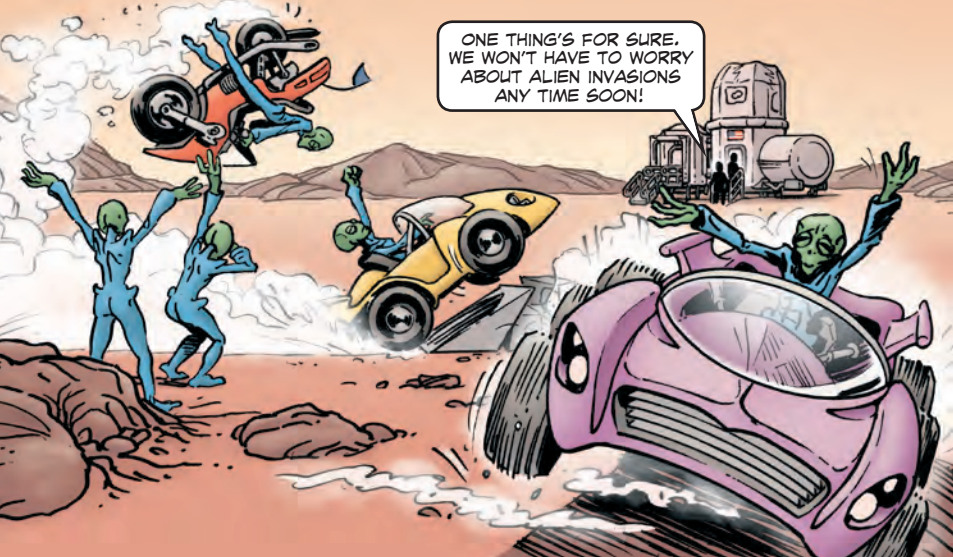
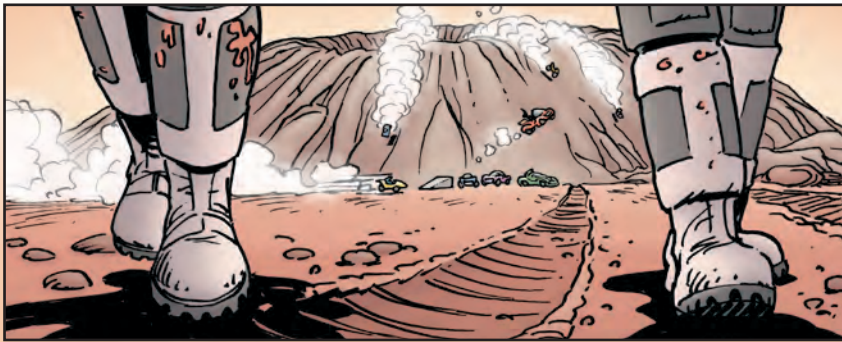

PS SMALL ARMS

ALSO
FEATURING
**TOOLS,
MISSILES,
AND
CBRN**

- Small Arms Help from Ft Carson
- SFL Pen for Small Arms Touch-ups
- M3 Rifle TMs Now Online
- Turning in Small Arms Parts? Check SMR Codes
- What Weapons Can You Camouflage?
- Silicone Grease Can Help
- Do Your BIT for MITAS Sake
- Subscribe to MLRS/HIMARS Newsletter
- Better Detecting with PM

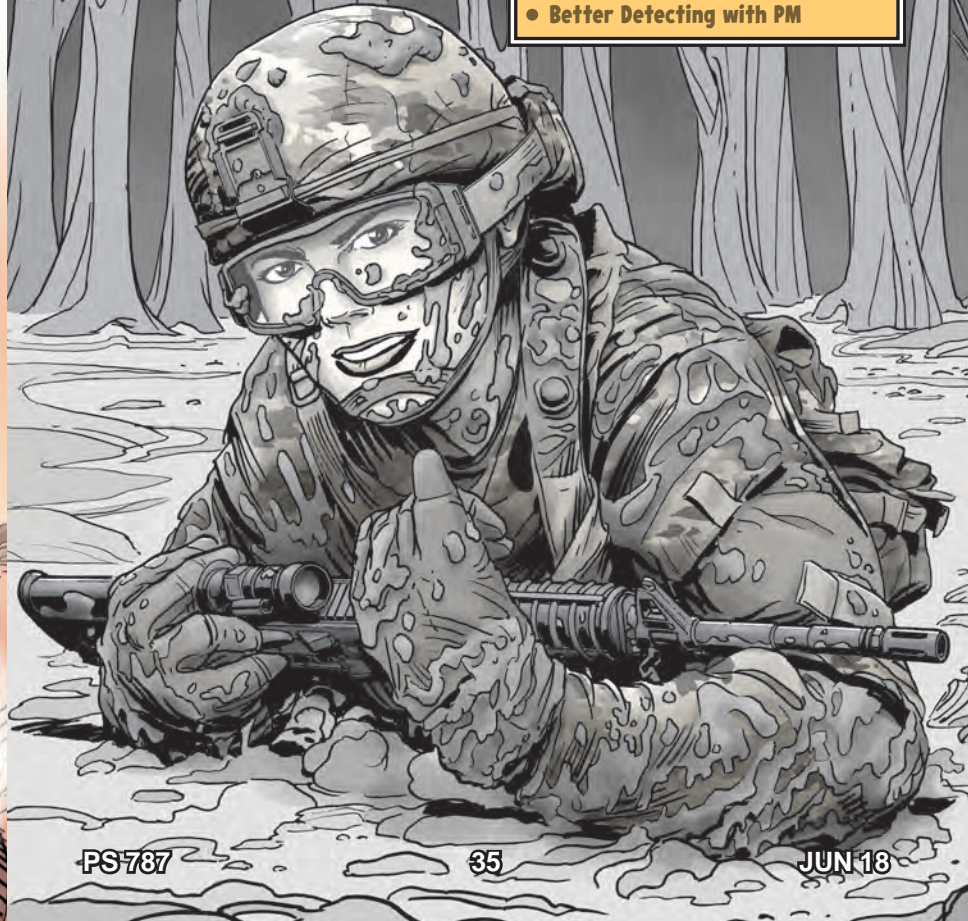

SMALL ARMS HELP FROM FT CARSON

LISTEN TO THESE WISE WORDS FROM THE LRC SMALL ARMS FOLKS AT FT CARSON.



Dear Editor,

At the Logistics Readiness Center (LRC), we see these small arms problems repeatedly. Soldiers and armorers can make it easier for themselves and their weapons by remembering these tips:

Lube like it says in the weapon's -10 TM. We see weapons at either lubeing extreme: bone dry or dripping with CLP. A weapon stored with no lubrication will soon be attacked by corrosion and damaged, maybe severely. A weapon with too much lubrication will quickly have firing problems in the field. Every -10 TM has very precise lubeing directions. Follow them! It's a good idea for armorers to make copies of the directions and give them to every Soldier. Correct lubeing is also a good topic for Sergeants' Time Training.

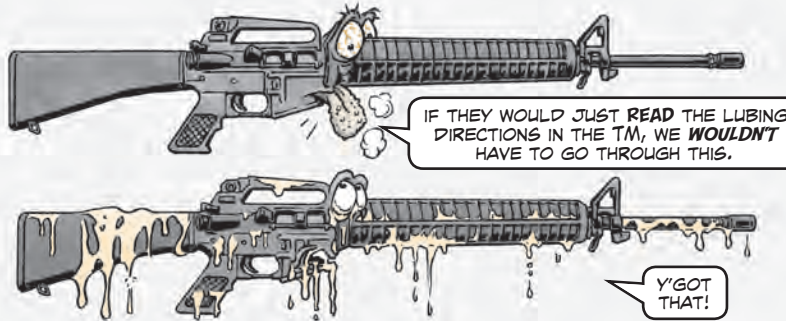

Think relaxed for storage. Armorers store weapons cocked. Why? Soldiers store lock and clear their weapons before they turn them in to the arms room. Armorers leave the hammer cocked and the bolt locked to the rear when they put the weapon in the rack. That tension on hammer and trigger springs causes them to weaken. Then the springs have to be replaced. Leaving the bolt locked back also weakens the recoil spring, which could cause jamming.

Things get even worse with the M16 rifle and M4 carbine. Storing them cocked can also cause them to fail the trigger pull test. Then the hammer and trigger pins must be removed and reinstalled. If that happens too often, the pins' holes enlarge and fail gaging. Then the lower receiver must be replaced.

If armorers do this *every time* they store a weapon, all those problems disappear: Leave the bolt or slide forward, the selector on SEMI for the M16/M4 or off SAFE for pistols and machine guns, and the hammer uncocked.

Help the springs for the M2 and MK 19 last longer by storing them muzzle down when possible.

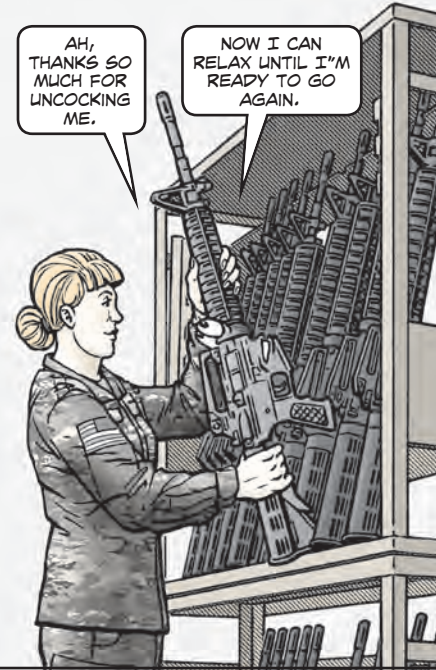

Pay attention to the M2's feed. If you get the feed wrong, you'll not only be unable to feed ammo in the M2, but you'll also damage the feed pawl guide lever when you slam the feed cover in place.

Just a glance at the bolt switch can tell you if you've got the feed right. If you're firing with the left-hand feed, the left groove beginning at the bolt's base should run through the bolt switch unblocked. Right hand feed? The right groove should be unblocked.

M2 gunners should be reminded to *always* check the feed before firing.

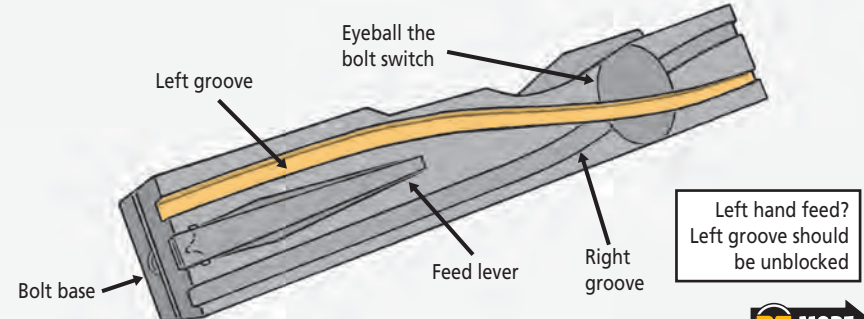

No unauthorized mods. Putting stuff like unauthorized grips or slings on weapons are bad for the weapon, but also your pocketbook. When weapons are turned in for repair or maintenance, those unauthorized items are removed and you'll never see them again.

CHECK OUT MY M16! I'VE REALLY DECKED IT OUT GOOD!

YOU DO REALIZE ALL THIS STUFF *DISAPPEARS* AS SOON AS I GO FOR REPAIR. NOT ONLY THAT, BUT I *DON'T* NEED ANY OF IT.

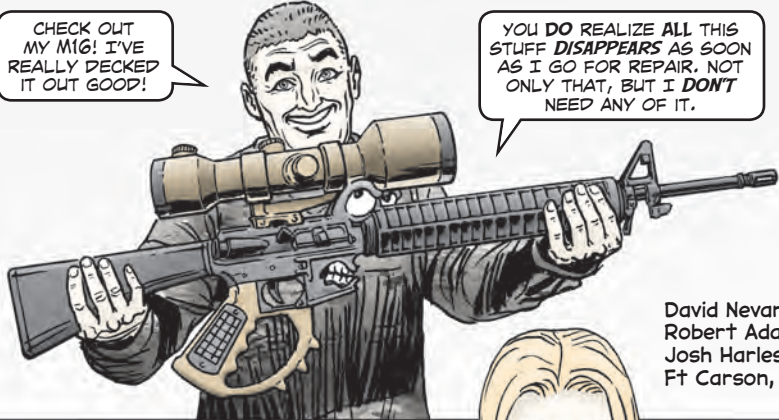

David Nevarez
Robert Adair
Josh Harless
Ft Carson, CO

IF SOLDIERS FOLLOW YOUR ADVICE, MANY SMALL ARMS PROBLEMS WILL *DISAPPEAR*. THANKS FOR THE HELP!



SFL Pen for Small Arms Touch-ups

TOUCHING UP WEAPONS WHERE THE FINISH HAS WORN OFF JUST GOT EASIER!

REPAIRMEN, YOU CAN NOW ORDER A SOLID FILM LUBRICANT (SFL) PAINT PEN DISPENSER WITH NSN 9150-01-646-0099.

THE DISPENSER MAKES TOUCHING UP NICKS, SCRATCHES AND SHINY SPOTS A SNAP!

THE PEN COSTS \$33.



M3 Rifle TMs Now Online!

IF YOU NEED INFO ON YOUR M3 84MM RECOILLESS RIFLE, YOU *DON'T* NEED TO LOOK ANY FURTHER THAN ETM ON LIW. BOTH TM 9-1015-262-10 AND -238P HAVE BEEN POSTED TO ETM:

<https://liw.logsa.army.mil/etmapp/#/etm/home>



TURNING IN SMALL ARMS PARTS? CHECK SMR CODES!

DO WE DISPOSE OF YOU LOCALLY OR TURN YOU IN TO BE DISPOSED OF SOMEWHERE ELSE?

IT'S EASY! ALL YOU GOTTA DO IS CHECK MY SMR CODE.

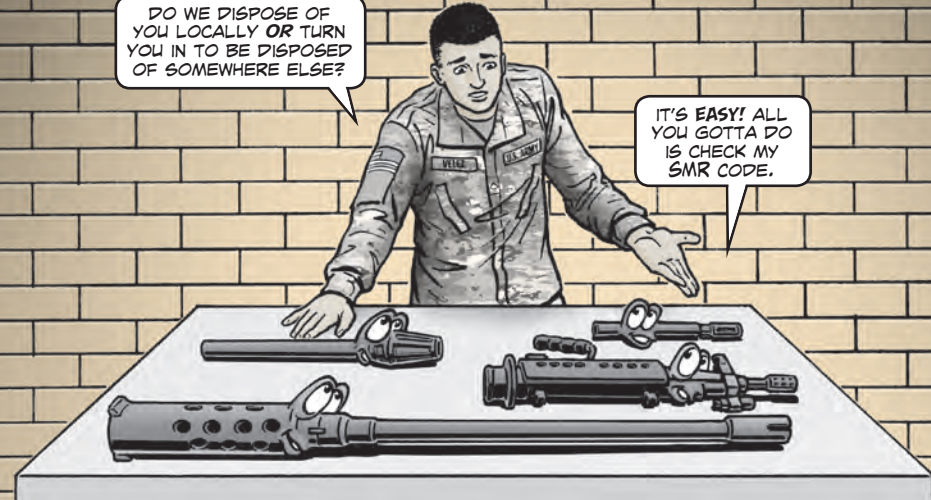

PAY ATTENTION TO THE SMR CODES WHEN YOU TURN IN UNSERVICEABLE CLASS IX SMALL ARMS REPAIR PARTS.

UNITS ARE *MISTAKENLY* TURNING IN PARTS THAT SHOULD BE DISPOSED OF AT FIELD LEVEL.



IT'S EASY TO TELL WHAT SHOULD BE DONE WITH AN UNSERVICEABLE PART! IN THE WEAPON'S -238P TM, CHECK THE *5TH POSITION* OF THE PART'S SMR CODE.

IF IT'S C, O, F OR H, *DISPOSE OF THE PART LOCALLY.*

IF IT'S ANYTHING ELSE, *TURN IN THE PART.*

GENERALLY, ALMOST ALL CLASS IX SMALL ARMS PARTS CAN BE DEMILLED LOCALLY, EITHER BY THE SMALL ARMS REPAIR SHOP OR THE BSB'S WELDING SHOP.

THIS *CONTRADICTS* THE INFORMATION THAT WAS ON PAGE 41 IN PS 776 (JUL 17), WHICH TOLD UNITS TO TURN IN UNSERVICEABLE SMALL ARMS PARTS TO DLS DISPOSITION SERVICES (DLA DS).

ALMOST ALL SMALL ARMS REPAIR PARTS CAN BE DEMILLED LOCALLY AND *DON'T* NEED TO GO TO DLA DS.

FOR MORE INFORMATION, SEE TACOM-SBC SUPPLY ADVISORY MESSAGE 17-986:
<https://tulsa.tacom.army.mil/Safety/message.cfm?id=SAM17-986.html>

FOR MORE INFO ON SMR CODES, SEE PAGES 55-59 OF PS 775 (JUN 17):
<https://www.logsa.army.mil/psmag/archives/PS2017/775/775-55-59.pdf>

WHAT WEAPONS CAN YOU CAMOUFLAGE?

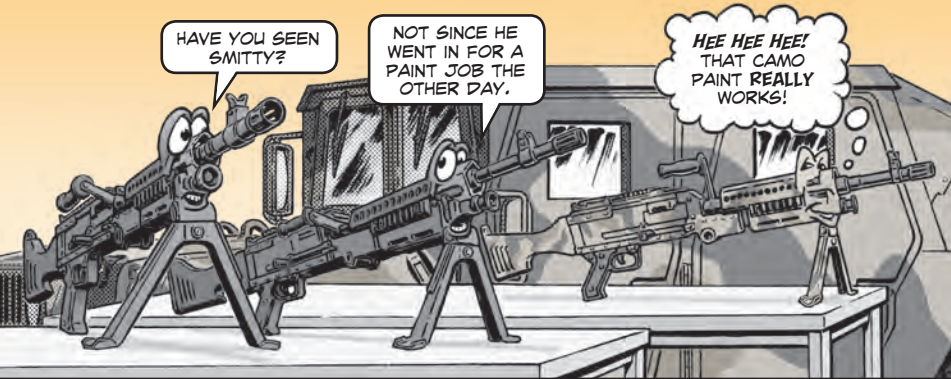

HAVE YOU SEEN SMITTY?

NOT SINCE HE WENT IN FOR A PAINT JOB THE OTHER DAY.

HEE HEE HEE! THAT CAMO PAINT REALLY WORKS!

Dear Half-Mast,
We would like to camouflage paint our weapons, but we're not sure if that's allowed or how to do it. Can you help?

SSG S.I.

OF COURSE, SERGEANT!



TACOM MAINTENANCE INFORMATION (MI) MESSAGE 15-002 GAVE INSTRUCTIONS FOR CAMOUFLAGE PAINTING M16 RIFLES AND M4 CARBINES. FIND IT AT:
<https://tulsa.tacom.army.mil/Maintenance/message.cfm?id=MI15-002>

INSTRUCTIONS FOR PAINTING THE M240 AND M249 MACHINE GUNS ARE IN TACOM MESSAGE 15-021, WHICH CAN BE FOUND AT:
<https://tulsa.tacom.army.mil/Maintenance/message.cfm?id=MI15-021.html>

REMEMBER YOU **MUST** GET YOUR COMMANDER'S APPROVAL **BEFORE** PAINTING M16s, M4s, M240s OR M249s.

AND REMEMBER THAT BEFORE YOU **TURN IN** THESE WEAPONS FOR REDEPLOYMENT OR TRANSFER ALL THE PAINT MUST BE **REMOVED**. INSTRUCTIONS FOR REMOVING THE PAINT ARE IN THE TACOM MESSAGES.



THERE ARE NO AUTHORIZED DIRECTIONS FOR CAMOUFLAGE PAINTING SNIPER RIFLES.

SILICONE GREASE CAN HELP!



SILICONE GREASE IS HANDY TO KEEP AROUND YOUR SHOP OR MOTOR POOL.

It works great for lubricating and preserving rubber parts, like O-rings. It doesn't swell or soften the rubber, which hydrocarbon-based greases can do. Silicone grease does a good job as a corrosion inhibitor, especially when a thicker lubricant is needed. And it's electrically insulating and doesn't break down when high voltage is applied. That makes it good for electrical connectors, particularly those containing rubber gaskets. It lubricates and seals rubber portions of the connector without causing arcing.

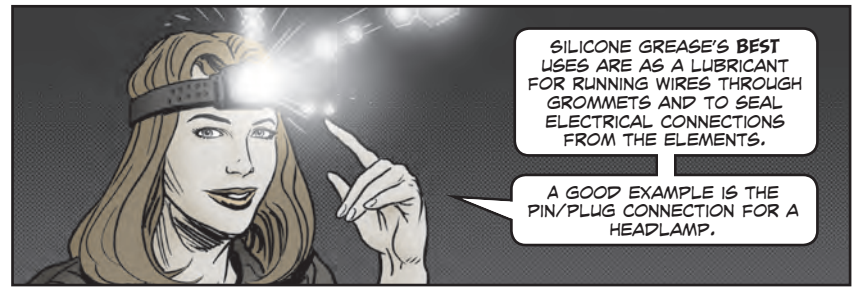

SILICONE GREASE'S BEST USES ARE AS A LUBRICANT FOR RUNNING WIRES THROUGH GROMMETS AND TO SEAL ELECTRICAL CONNECTIONS FROM THE ELEMENTS.

A GOOD EXAMPLE IS THE PIN/PLUG CONNECTION FOR A HEADLAMP.

Order an 8-oz tube of silicone grease with NSN 6850-00-880-7616. But you don't want to use silicone grease in sandy areas because it attracts sand. Then it's better to use a "dry" silicone spray. It has some cleaning ability, but its main advantage is that it dries almost instantly and doesn't act as a magnet for sand. Order silicone spray with NSN 7930-01-380-9028. That brings a dozen 11-oz cans for around \$150. Or you can buy a single can with NSN 9150-01-039-4745.

DO YOUR BIT FOR MITAS SAKE

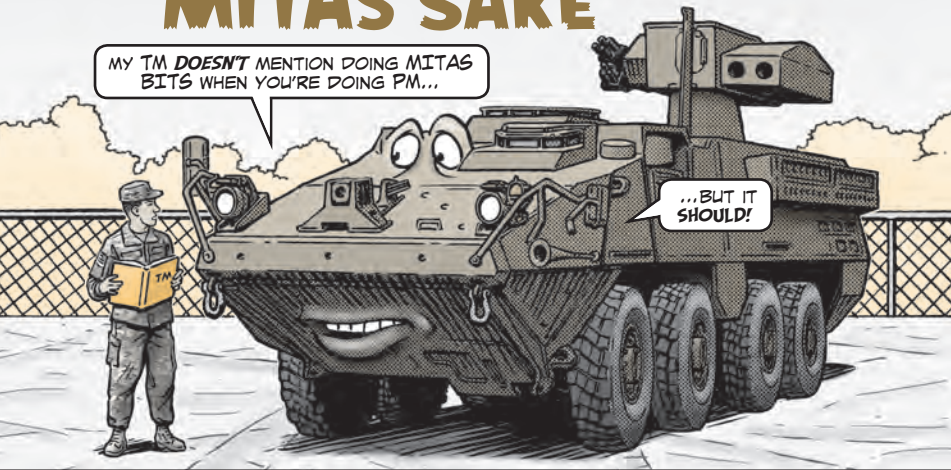

Dear Editor,

The M1134 Stryker's TM *doesn't* mention doing built-in tests (BITs) for the MITAS during PMCS.

It *should*. Along with the operational checkout, the MITAS's BITs (PBIT, IBIT, BORSGT, GRIPS) are the best way to ensure MITAS is working properly. And it's easy to do:

1. Power up the MITAS following the TM procedure and wait for the system to cool. It should cool within 15 minutes. The NOT COOL indicator in the bottom right of the Gunner's MITAS screen will disappear once the system is cool enough.
2. PBIT was done automatically when the MITAS was powered up. PBIT checked the power distribution and the operational circuits needed to engage targets with the day sight.
3. Select MENU-BIT-IBIT to run IBIT to check all FLIR operational circuits.

Main menu CANCEL RANGE BIT BORSGT TNG

BIT menu CANCEL IBIT GRIPS TAS MAINT

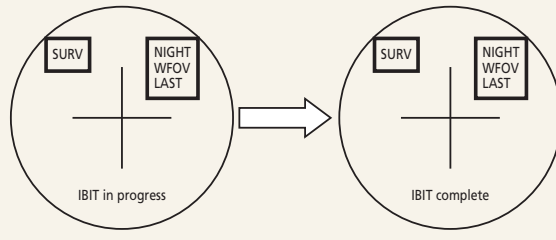

4. Once the IBIT is finished, boresight MITAS by selecting BORSGT. This aligns the day sight and FLIR. Remember to close the sight door first and make sure there is no movement of the MITAS or turret during boresighting.
5. Next select MENU-BIT-GRIPS and follow the instructions to test the gunner station hand grip controls.

Accidentally hitting the wrong button during the GRIPS test produces an error icon. If MITAS fails the GRIPS test, test it again before calling in your 91S repairman.

6. If the BITs ID any mission critical failures, you'll see failure icons at the bottom of the MITAS display. Report them to your 91S. If it passes, you're good to go.

SFC Stephen Brown
Stryker Master Gunner Course
Ft Benning, GA

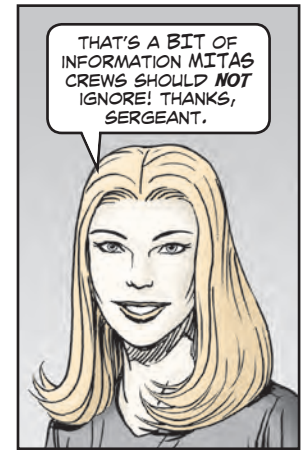

Subscribe to MLRS/HIMARS Newsletter!



MLRS and HIMARS units need to get on the email list for *MFOM Precision Points*, a newsletter devoted to the MLRS family of munitions.

The newsletter, which comes out as needed, gives the latest info on POCs, publications, maintenance changes and other munitions topics.

To request to be added to the email list, email:

usarmy.redstone.peo-ms.mbx.fieldconcerns@mail.mil

BETTER DETECTING WITH PM

TRY THESE TIPS FROM FT CARSON TO MAKE DETECTING EASIER FOR YOUR M1135 NBCRV STRYKER.

IF I'M DETECTING BETTER, WE'RE ALL DOING BETTER!

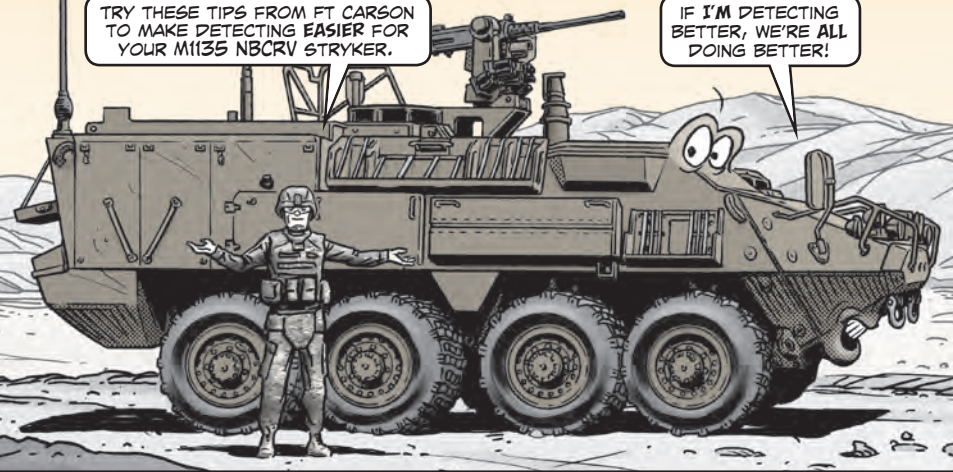

MAKE SURE THE CONSUMABLE BOTTLES ARE SEATED AND LOCKED IN PLACE.

IF A BOTTLE *ISN'T* FULLY SEATED AND LOCKED, YOU'LL GET FAULTS. AND SOMETIMES IT'S *DIFFICULT* TO IDENTIFY WHAT'S CAUSING THOSE FAULTS.

TO INSTALL A BOTTLE, PULL THE COUPLING BACK, CONNECT THE BOTTLE AND PUSH THE COUPLING FORWARD TO LOCK THE BOTTLE IN PLACE. THEN GIVE THE BOTTLE A LITTLE TUG TO MAKE SURE IT'S SECURE. ALSO MAKE SURE THE CAPS AREN'T LEAKING. SOMETIMES THEY CORRODE AND START LEAKING.

DON'T LEAVE THE STRYKER SHUT UP FOR LONG PERIODS, ESPECIALLY IN HUMID AREAS.

AT LEAST EVERY OTHER WEEK, OPEN UP THE STRYKER AND RUN THE A/C TO DRY UP ANY MOISTURE. THAT *PREVENTS* A NASTY CASE OF MILDEW FROM FORMING.

MOISTURE CAN ALSO CAUSE FAULTS WHEN YOU'RE READY TO OPERATE THE CHEMICAL BIOLOGICAL MASS SPECTROMETER (CBMS).

YOU HAVEN'T OPENED ME UP FOR A MONTH! I DON'T THINK YOU WANT TO SEE WHAT I *LOOK* LIKE INSIDE.

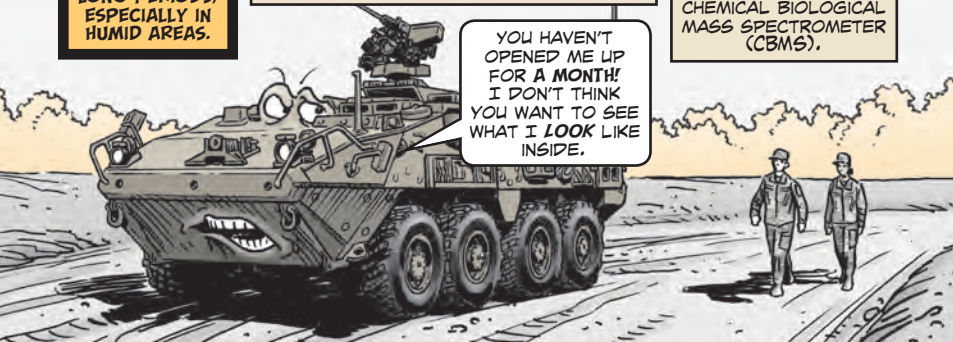

BE PATIENT WHEN TROUBLESHOOTING WITH BIT.

SOMETIMES IT CAN TAKE AS LONG AS 30 MINUTES FOR THE TEST TO RUN ITS COURSE.

GIVE THE BIT TIME ENOUGH TO DO ITS JOB. IF NOTHING SHOWS UP AFTER 30 MINUTES, THEN REPORT IT.

WAIT 30 MINUTES BEFORE YOU CALL A REPAIRMAN.

LET MY BIT DO ITS BIT *FIRST*.

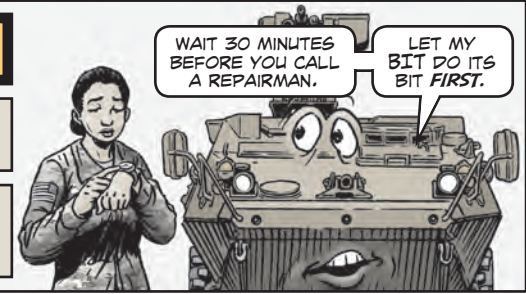

WHEN OPENING THE BOTTOM OF THE REAR DOOR, MAKE SURE ITS HANDLE IS COMPLETELY IN THE CLOSED POSITION BEFORE LETTING THE DOOR SWING DOWN.

OTHERWISE, THE DOOR HANDLE CAN BE *DAMAGED*.

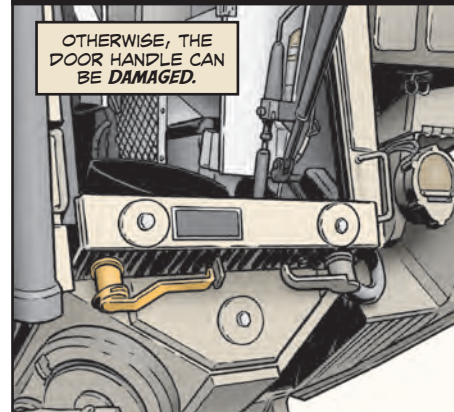

BEFORE INSTALLING A TRAINING SAMPLE CANISTER IN THE CHEMICAL VAPOR SAMPLING SYSTEM (CVSS), VACUUM IT.

IF YOU *DON'T*, THE TRAINING CANISTER WILL READ **NOT READY...**

...AND YOU'LL WASTE TIME FIGURING OUT WHAT'S WRONG.



Training canisters have a blue top

DO ALL THE SUITE SYSTEM CHECKS WEEKLY.

MAKE THEM PART OF YOUR MONDAY PMCS. LETTING THE SYSTEMS OPERATE WILL SAVE LOTS OF TROUBLESHOOTING LATER.

REPORT PROBLEMS ON A DA FORM 5988 OR 2404.

THAT'S THE ONLY WAY THEY GET FIXED!

OK, YOU KNOW I'VE GOT PROBLEMS. BUT THEY *WON'T* GET FIXED *UNLESS* YOU WRITE THEM UP.

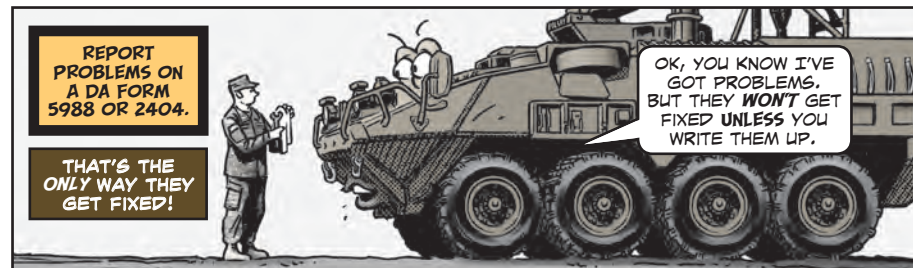

PS COMMUNICATIONS & SOLDIER SUPPORT

- Driver's Vision Enhancer Sensors Get Enhanced
- Easy Does It Installing RT
- How to Get PLS Radio Kit
- Refrigerant Change Sparks Alert
- Knock Three Times



ANVAS-5 Series...

Driver's Vision Enhancer Sensors Get Enhanced

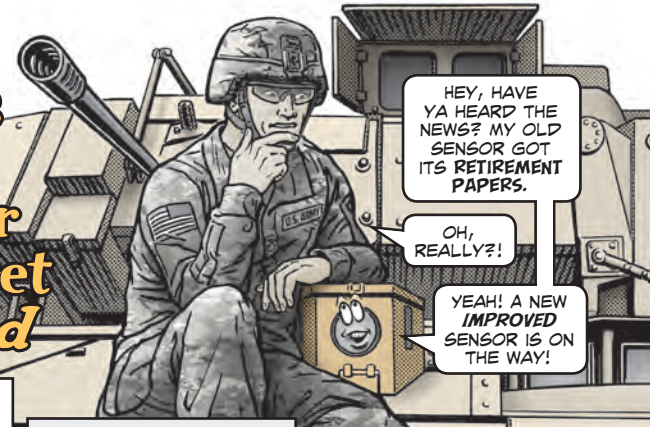

HEADS UP IF YOU'RE ONE OF THE MANY USERS OF THE DRIVER'S VISION ENHANCER (DVE), LIN D41659. THE EXISTING 25-MICRON FAMILY OF DVE SENSORS IS BEING REPLACED THROUGH ATTRITION BY A NEW 17-MICRON SENSOR WITH ENHANCED TECHNOLOGY.

THE NEW LENS ARRAY IS SMALLER BUT **WILL** WORK WITH THE OLD HOUSING.

- IMPROVEMENTS INCLUDE:
- pixel pitch
 - less power consumption
 - MIL-STD-1275D power compliance

Driver's Vision Enhancer, LIN D41659

CHECK OUT THE OLD AND NEW NSNs:

Nomenclature	25-micron sensors	New 17-micron sensors
	Old NSNs	New NSNs
Combat Vehicle Sensor (CV Sensor-V3)	5855-01-525-1636	5855-01-661-4314
CV Sensor-V5	5855-01-588-3771	
Tactical Wheeled Vehicle Sensor (TWV Sensor-V3)	5855-01-525-1631	
TWV Sensor-V5	5855-01-588-3763	5855-01-661-4313
TWV Sensor by BAE (No longer procurable)	5855-01-587-5899	
Abrams CV Sensor	5855-01-599-3102	5855-01-662-0300

GOT DVE QUESTIONS? CONTACT:

SHELLY COLELLO AT (443) 861-3017, EMAIL: shelly.a.colello.civ@mail.mil OR
GLENN CASSIMORE AT (443) 861-2954, EMAIL: glenn.a.cassimore.civ@mail.mil

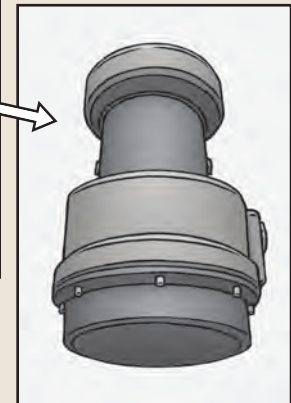
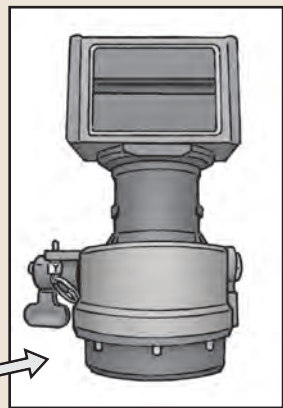

Easy Does It Installing RT



GUIDE RAILS, NSN 5975-01-467-4678, MAKE MOUNTING EASIER. THE RAILS CLOSE THE GAP BETWEEN THE RIGHT SIDE OF THE RADIO AND THE MOUNT.

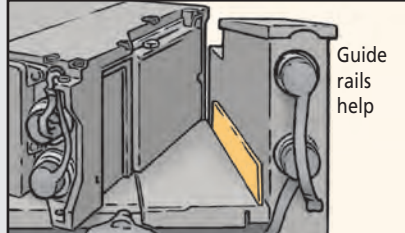

BUT DON'T DEPEND ON THEM ENTIRELY. EVEN WITH THE RAILS, THE CONNECTORS ARE USUALLY NOT PERFECTLY ALIGNED.

IF YOU NEED INSTRUCTIONS FOR MOUNTING THE GUIDE RAILS, EMAIL PS AT:

BE AWARE THAT EVEN WHEN THE RT IS INSTALLED PROPERLY AND LOCKED DOWN, VIBRATION CAN CAUSE IT TO SHIFT ENOUGH THAT THE RT LOSES ITS CONNECTION.

usarmy.redstone.logsa.mbx.psmag@mail.mil

Dear Editor,

We have had a real problem with Soldiers damaging the 17239 mount when they install the SINGGARS RT 1523E/F. They jam the SINGGARS in and break the P1 and GPS connectors. In one month we had 120 mounts damaged. It would be great if PS did an article on how to install SINGGARS properly.

SSG Clinton Hogue
Ft Polk, LA

WE HEAR YOU, STAFF SERGEANT.

INSTALLATION IS DIFFICULT BECAUSE THERE IS LEEWAY ON BOTH SIDES OF THE RT.

YOU CAN'T JUST PUT THE RT IN THE MOUNT AND SHOVE.

THAT ALMOST GUARANTEES BENT OR BROKEN CONNECTOR PINS.

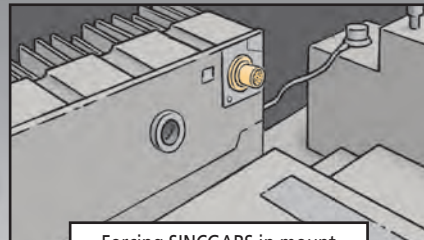

Forcing SINGGARS in mount damages P1 and GPS connectors

THE ONLY SOLUTION IS SLOW AND EASY WHEN INSTALLING THE RT.

EASE THE RT INTO THE MOUNT UNTIL YOU FEEL THE CONNECTORS MEET.

THEN CAREFULLY PUSH THE CONNECTORS TOGETHER.

IF THE CONNECTORS AREN'T LINING UP, REPOSITION THE RT AND TRY AGAIN. IF REPOSITIONING DOESN'T WORK, GET HELP FROM YOUR REPAIRMAN.

JUST DON'T TRY TO FORCE THE RT IN PLACE!

How to Get PLS Radio Kit

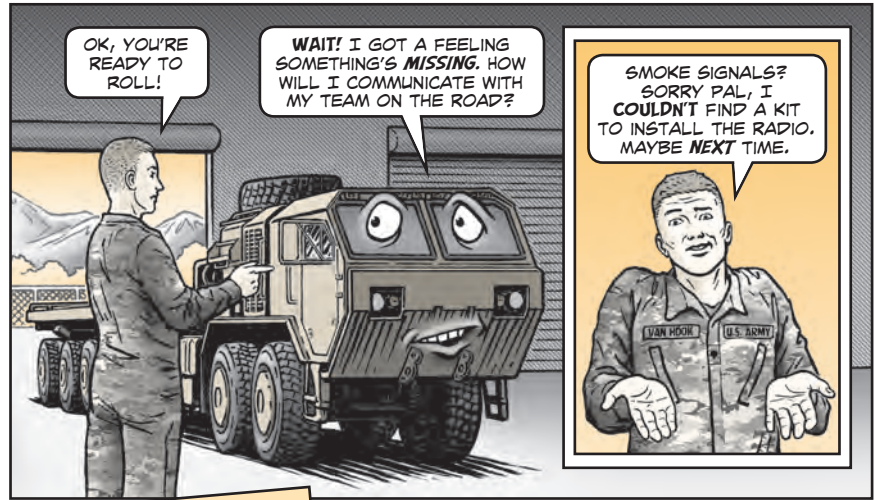

Dear Half-Mast,
What's the NSN for the radio installation kit for the M1075A1 PLS? I've searched through TM 9-2320-319-13&P (Mar 10) without luck. There's a section about installing a radio kit, but it doesn't give the kit's NSN.
SGT W.J.

Dear Sergeant,
MK-2694/VRC, NSN 5895-01-347-6187, is the radio installation kit for installing SINGGARS AN/VRC-87, -88 or -90 into PLS A1 (M1074A1/M1075A1) trucks. You'll find the installation instructions in TB 11-5820-890-20-84 (Sep 93). You can get the TB at the LOGSA ETM website. Go to: <https://liw.logsa.army.mil/etmapp/#/etm/home>

Half-Mast

REFRIGERANT CHANGE SPARKS ALERT

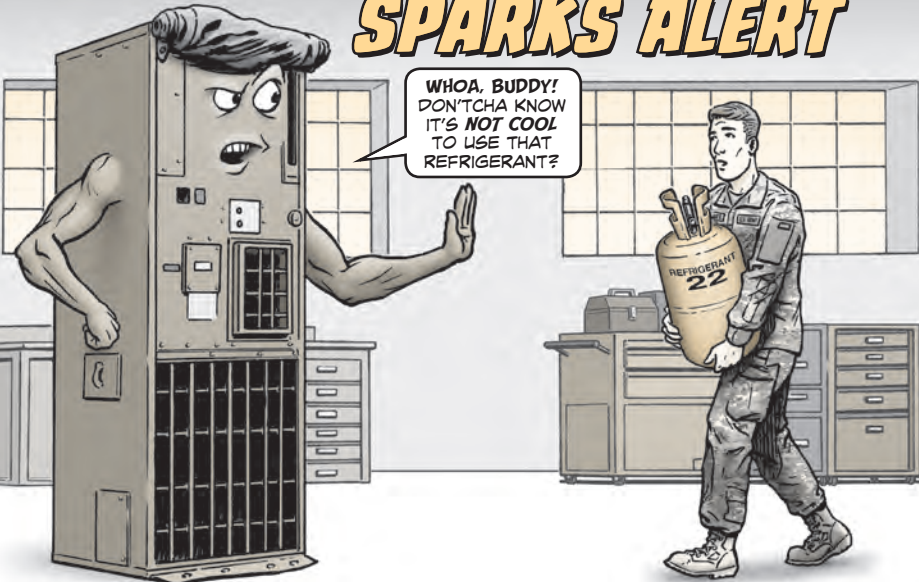

AS A SOLUTION, CECOM ILSC HAS TESTED AND APPROVED THE USE OF M099, ALSO KNOWN AS R438A, AS A SAFE AND SUITABLE "DROP-IN" REPLACEMENT REFRIGERANT FOR R22 IN LEGACY ECU SYSTEMS.

R438A REFRIGERANT IS ONLY AUTHORIZED FOR USE IN THE FOLLOWING ECU SYSTEMS...

BTU/hr	NSN 4120-	LIN
9,000, 1 PH	01-456-6954	A23828
9,000, 3 PH	01-330-6542	A23955
18,000 horizontal	01-523-4472	A24463
18,000 vertical	01-329-1515	A24455
36,000	01-467-2638	A24763

Unit Instructions

1. Be aware of any ECU systems that have already been charged (retrofitted) with R438A refrigerant with identification plates stating that the newer refrigerant was applied.

Note: This is a critical step to ensure the two refrigerants aren't mixed, which can cause a chemical/pressure imbalance, making ECU systems NMC.

Apply identification plates to retrofitted ECU systems

RETROFITTED BY:
TOBYHANNA ARMY DEPOT

System Charged with
 Refrigerant M099 (R-438A) 2.54 lbs.

Date Retrofitted: 4/09/14

2. Units performing retrofits should contact the CECOM representatives listed below or LARS to acquire CAUTION identification plates to be attached to retrofitted ECU systems.
3. R438A retrofits are to be performed on an as-needed basis (attrition), unless units are informed otherwise or unit resources become available.
4. Units are asked to retrofit ECU systems to R438A prior to deployments in theater.
5. If R438A is not available through DLA and service is necessary, local purchase is authorized through LAR-approved sources.

HERE'S AN IMPORTANT MESSAGE FOR UNITS!

REFRIGERATION AND MAINTENANCE SERVICES ON ENVIRONMENTAL CONTROL UNIT (ECU) SYSTEMS THAT CONTAIN A REFRIGERANT KNOWN AS R22 ARE NO LONGER AUTHORIZED TO BE PERFORMED IN OCONUS LOCATIONS IN EUROPE.

THIS RESTRICTION INCLUDES SERVICE PROCEDURES LIKE FULL REFRIGERANT CHARGES AND/OR "TOPPING OFF."

UNITS CAN CONTINUE TO OPERATE ECU SYSTEMS USING R22 UNTIL REFRIGERATION SERVICES ARE REQUIRED.

BUT ONCE ANY SERVICES ARE DUE, R22 MUST NOT BE USED AND/OR SERVICED.



R22 use may result in host nation fines

PERSONNEL STATIONED IN OCONUS WHO VIOLATED INTERNATIONAL RESTRICTIONS BY CONTINUING TO SERVICE R22, WHICH HAS OZONE-DEPLETING HYDROCHLOROFLOURCARBONS, HAVE BEEN PENALIZED AND FINED BY HOST NATIONS.

TAKE NOTE OF THESE R438A REFRIGERANT CHARGING PRESSURES.

BTU/hr	R438A lbs
9,000, 1 PH	1.90
9,000, 3 PH	1.90
18,000 horizontal	2.62
18,000 vertical	3.25
36,000	5.70



IF YOU HAVE QUESTIONS ON ECU SYSTEMS SUPPORT, CONTACT THE FOLLOWING CECOM ILSC POCS

KAREN ADAMS AT (443) 395-6898,
 EMAIL: karen.m.adams6.civ@mail.mil
SYDNEY MAPP AT (443) 395-6897,
 EMAIL: sydney.w.mapp3.civ@mail.mil
JOE SAVITSKY AT (443) 395-6241,
 EMAIL: joseph.t.savitsky.civ@mail.mil

KNOCK THREE TIMES



COMBAT IS TOUGH ENOUGH, EVEN WHEN YOU HAVE **COMPLETE CONFIDENCE** IN YOUR BODY ARMOR. **DO REGULAR INSPECTIONS** TO MAKE SURE YOU'RE **PROTECTED**.



HARD ARMOR INSERTS HAVE **SAVED THE LIVES** OF MANY SOLDIERS IN COMBAT. BUT LIKE ANY EQUIPMENT, BODY ARMOR NEEDS TO BE **INSPECTED** BEFORE USE.

YOU CAN CHECK YOUR PLATES AND CONDUCT **SIMPLE TESTS** TO ENSURE THAT YOUR ENHANCED SMALL ARMS PROTECTIVE INSERTS (ESAPI) ARE INTACT AND WILL OFFER LIFE-SAVING **PROTECTION**.

BECAUSE PLATE DAMAGE **ISN'T** ALWAYS VISIBLE, DO THESE **TWO TESTS** TO HELP **ENSURE** YOUR ESAPI IS FIT FOR THE FIELD: THE **TAP TEST** AND THE **TORQUE TEST**.



The Tap Test

THE TAP TEST CHECKS FOR **DELAMINATION** OF THE HARD ARMOR PLATES.

HERE'S HOW TO DO IT...

THE TAP TEST SHOULD BE DONE IN A **QUIET AREA** SO YOU CAN **HEAR** THE TAPS.

USE A PROPER TOOL FOR THE TEST. A TAP TEST TOOL MUST BE A **DENSE, SOLID METAL OBJECT**, LIKE A BOLT, METAL PIN OR FOLDING KNIFE.



Bolt Metal pin Folding knife

NOTE: THE TAP TEST SHOULD **NOT** BE DONE ON THE ESAPI'S SIDES.

WHEN DOING THE TAP TEST, REST THE PLATE ON THE FINGERTIPS OF YOUR **NON-DOMINANT** HAND.

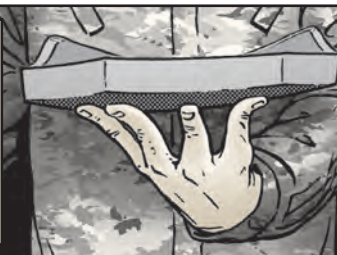

TAP IN THE **UPPER PORTION** OF THE PLATE.

WHILE TAPPING ON THE PLATE, LISTEN FOR **ONE OF TWO SOUNDS**: EITHER A **CHIME** (THREE TINNY CHIMES) OR A **THUD** (THREE DULL THUDS).

A CHIME-LIKE SOUND MEANS THE PLATE **ISN'T** DELAMINATED. A THUDDING SOUND MEANS THE PLATE MAY BE DELAMINATED.

WHEN TAPPING A PLATE, IF YOU HEAR **THREE DULL THUDS**. PUT THAT PLATE ASIDE. **DON'T** ISSUE OR USE THE PLATE BECAUSE THERE MAY BE DELAMINATION ISSUES.

THERE ARE TWO EXCEPTIONS TO THIS RULE!

1. Tapping directly in the center of the plate will **always** result in a solid sound (three tinny thuds). The amount of surrounding material acts as a dampener, which prevents large amounts of resonance.
2. If you tap a plate directly on a label, you may also hear a solid sound (three tinny thuds). However, that **doesn't** mean the plate is delaminated because the curvature of the plate in this area also dampens the resonance.

SOLUTION: AVOID TAPPING IN THESE TWO AREAS.



The Torque Test

THE TORQUE TEST INSPECTS FOR CRACKS IN THE CERAMIC TILE IN THE HARD ARMOR PLATE.

DO THE TEST IN A QUIET PLACE.



START BY SHAKING THE PLATE.

GRAB ONE CORNER OF THE PLATE WITH ONE HAND AND THE OPPOSITE CORNER WITH THE OTHER HAND, AND TORQUE, OR TWIST, THE PLATE.

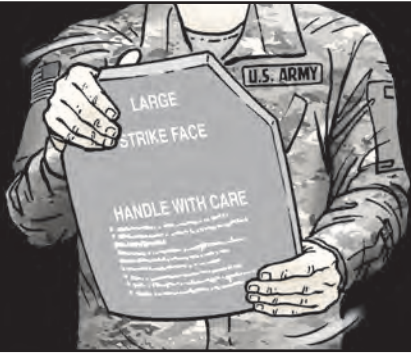

LISTEN FOR ANY CRUMBLING, CRACKING OR RATTLING SOUNDS.



SWITCH HANDS TO THE OPPOSITE CORNERS OF THE PLATE AND TWIST AGAIN, LISTENING CAREFULLY FOR ANY CRUMBLING, RATTLING OR CRUNCHING SOUNDS.

FEEL AROUND THE OUTER EDGES OF THE PLATE, TOO.

ENSURE THAT YOU GO **ALL THE WAY AROUND** THE PLATE, BECAUSE THE **OUTER EDGE** IS THE MOST SUSCEPTIBLE TO DAMAGE.

PLATES SHOULD BE SCANNED EVERY NINE MONTHS.

A SCANNED PLATE DISPLAYS A SILVER STICKER THAT SHOWS THE LAST DATE IT PASSED INSPECTION.



NDTE 05

Passed Inspection

3/17/2016

Silver sticker shows last time plate passed inspection

ALL PLATES THAT ARE FOUND UNSERVICEABLE BECAUSE OF FAILING EITHER THE TAP TEST OR THE TORQUE TEST SHOULD BE **PULLED AND DISPOSED OF** IN ACCORDANCE WITH ARMY GUIDANCE.

FOR A STEP-BY-STEP VIDEO SHOWING THE PROPER WAY TO DO BOTH THE TAP AND TORQUE TESTS ON YOUR ESAPI, VISIT:

<https://www.dvidshub.net/video/473427/peo-soldier-armored-plate-tap-test-training>



- Scared Stiff of Corrosion
- Desiccant In Action

SCARED STIFF OF CORROSION



THE REAPING WILL TAKE YOU ALL!

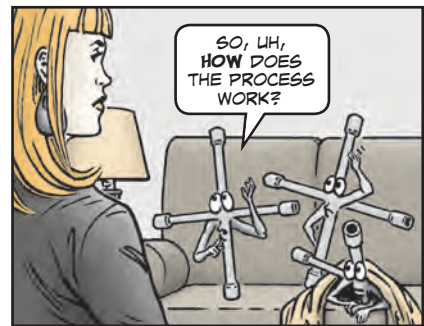

SO, UH, HOW DOES THE PROCESS WORK?

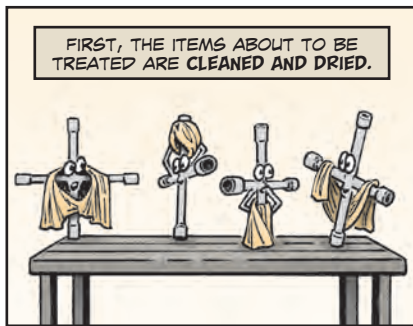

FIRST, THE ITEMS ABOUT TO BE TREATED ARE CLEANED AND DRIED.

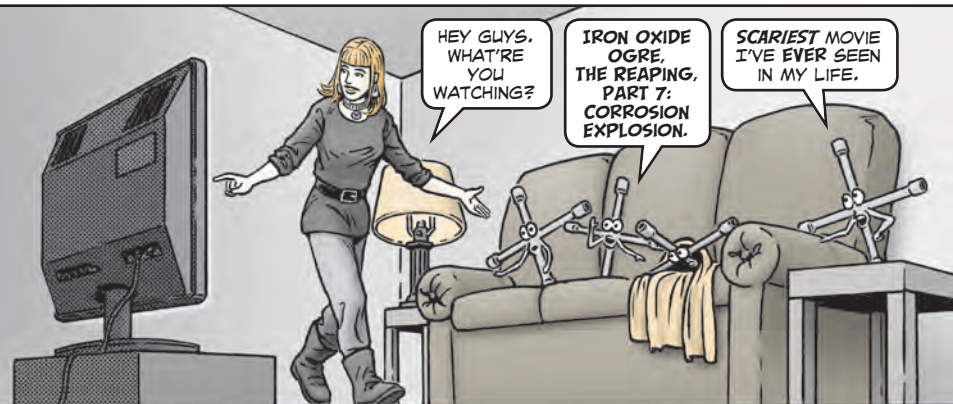

HEY GUYS. WHAT'RE YOU WATCHING?

IRON OXIDE OGRE, THE REAPING, PART 7: CORROSION EXPLOSION.

SCARIEST MOVIE I'VE EVER SEEN IN MY LIFE.

THEN THE CORRECT PREVENTIVE COMPOUND IS SELECTED, PER MIL-STD-2073-1 (STANDARD PRACTICE FOR MILITARY PACKAGING) AND APPLIED TO THE ITEM EITHER BY:

- dipping
- slushing
- flow coating
- spraying
- flushing
- fogging
- brushing

AFTER THE ITEMS ARE TREATED, THEY'RE TUCKED AWAY IN A WRAP THAT CONFORMS TO MIL-PRF-121, TYPE I OR II, AND MARKED ACCORDING TO MIL-STD-129.



AHHH...

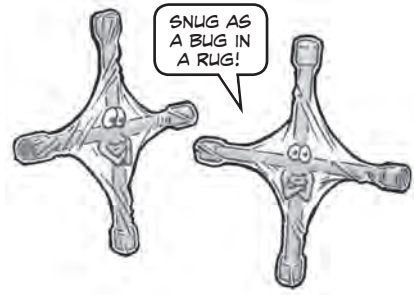

SNUG AS A BUG IN A RUG!

WE COULDN'T HAVE PICKED A WORSE SHOW TO WATCH RIGHT BEFORE WE HEAD INTO STORAGE.

WELL, YOU GUYS DON'T HAVE ANYTHING TO FEAR BECAUSE YOUR SOLDIERS WILL USE METHOD 20 TO PROTECT YOU FROM CORROSION BEFORE THEY STORE YOU.

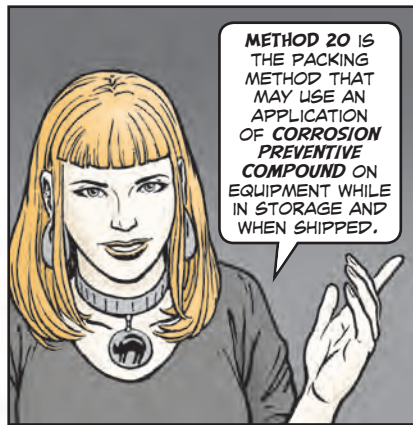

METHOD 20 IS THE PACKING METHOD THAT MAY USE AN APPLICATION OF CORROSION PREVENTIVE COMPOUND ON EQUIPMENT WHILE IN STORAGE AND WHEN SHIPPED.

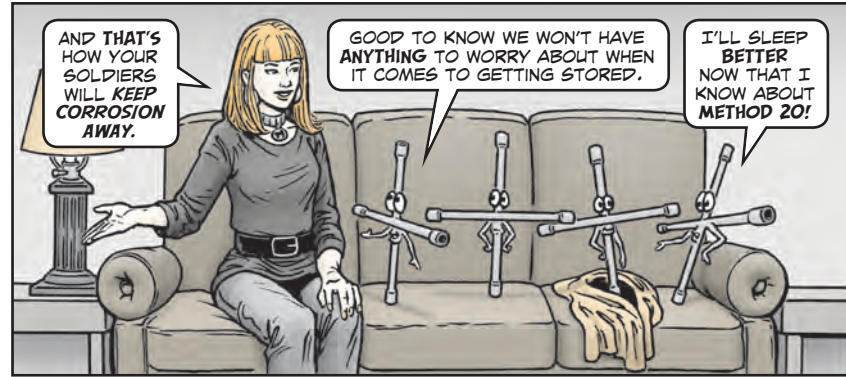

AND THAT'S HOW YOUR SOLDIERS WILL KEEP CORROSION AWAY.

GOOD TO KNOW WE WON'T HAVE ANYTHING TO WORRY ABOUT WHEN IT COMES TO GETTING STORED.

I'LL SLEEP BETTER NOW THAT I KNOW ABOUT METHOD 20!

FOR MORE ON METHOD 20 AND OTHER CORROSION PREVENTION AND PACKAGING TIPS DOWNLOAD THE PACKAGING, STORAGE AND CONTAINERIZATIONS CENTER'S (PSCC) PACKAGING - BASICS AT: https://www.logsa.army.mil/documents/LOGSAP_746-1.pdf

OR CHECK OUT PS MAGAZINE ISSUE 724 FROM MARCH 2013.

Desiccant In Action

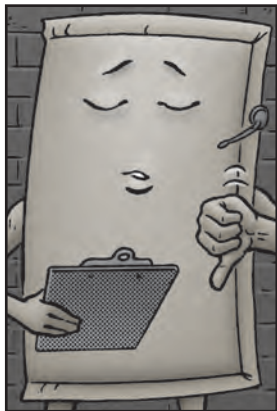
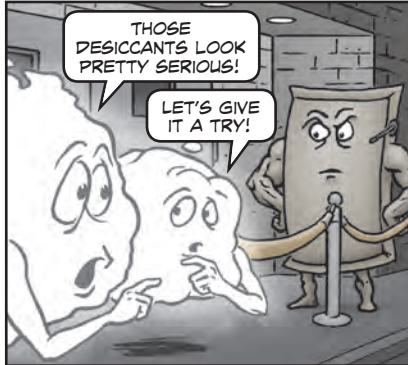
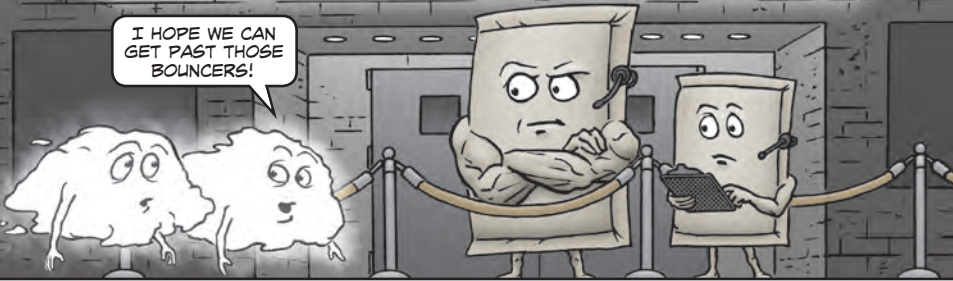

IF YOU'RE USING **METHOD 50** TO FIGHT CORROSION, THEN YOU'LL BE USING **MOISTURE-ABSORBING DESICCANT**.

DESICCANT **ABSORBS** WATER VAPOR THAT TRIES TO SNEAK THROUGH THE BARRIER MATERIAL DURING STORAGE OR SHIPPING.

WHILE DESICCANT IS DEFINITELY YOUR ALLY, THERE ARE A FEW RULES TO KEEP IN MIND **BEFORE** YOU START PACKING...



- When the item is protected in a watervaporproof bag enclosure, desiccant should be strategically placed to avoid direct contact with the item. The bag will be heat-sealed to ensure moisture can't enter the watervaporproof bag enclosure.
- Activated desiccant means the desiccant is already working to absorb moisture in its vicinity. **Don't** expose desiccant to the environment when removed from their sealed storage container any longer than necessary.
- Removing the activated desiccant and inserting it into the unit pack should be the **last** action before sealing the bag or container.
- Add a greaseproof wrap to any items using contact preservatives that separate the desiccant from incompatible elements. Be sure to secure desiccant bags around the item and use humidity indicators for all packs containing desiccant.
- **Never** use damaged or frayed bags of desiccant or store them near lubes or oils.
- **Don't** remove desiccant bags from their container until you're ready to use them.

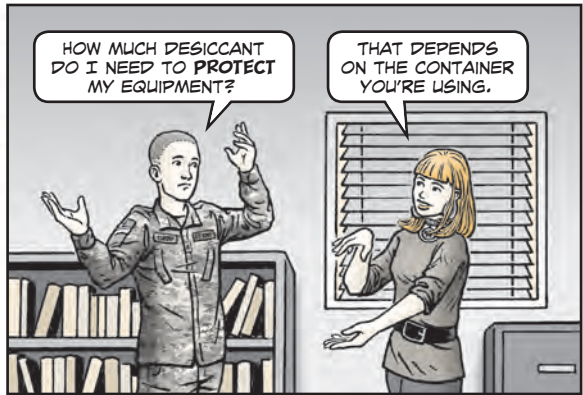

MANY HIGH DOLLAR ITEMS STORED IN LONG LIFE REUSABLE CONTAINERS (LLRCs) MAY HAVE DESICCANT INFORMATION AVAILABLE ON THE LLRC DATA PLATE. SPECIAL PACKAGING INSTRUCTIONS WILL PROVIDE THE INFORMATION AS WELL, IF IT'S AVAILABLE. THE ITEM'S TM CAN PROVIDE THE AMOUNT OF DESICCANT, TOO.



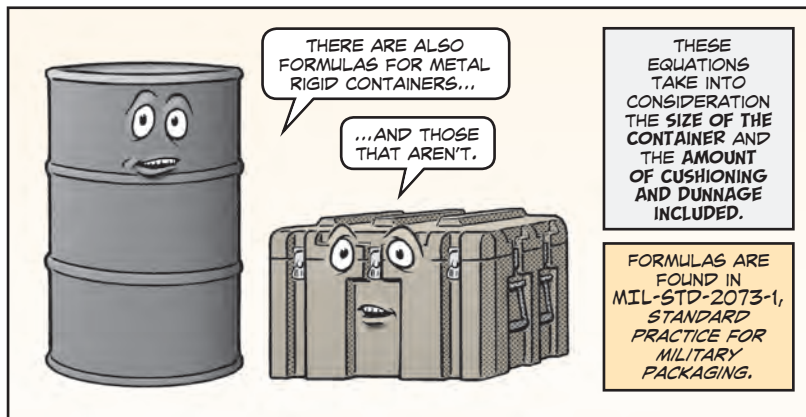

THERE ARE ALSO FORMULAS FOR METAL RIGID CONTAINERS...

...AND THOSE THAT AREN'T.

THESE EQUATIONS TAKE INTO CONSIDERATION THE SIZE OF THE CONTAINER AND THE AMOUNT OF CUSHIONING AND DUNNAGE INCLUDED.

FORMULAS ARE FOUND IN MIL-STD-2073-1, STANDARD PRACTICE FOR MILITARY PACKAGING.

STICK TO THESE FORMULAS WHILE USING METHOD 50 AND THE ACTIVATED DESICCANT WILL WORK TO KEEP MOISTURE AWAY FROM YOUR EQUIPMENT. THAT HELPS KEEP YOUR EQUIPMENT **CORROSION-FREE**.

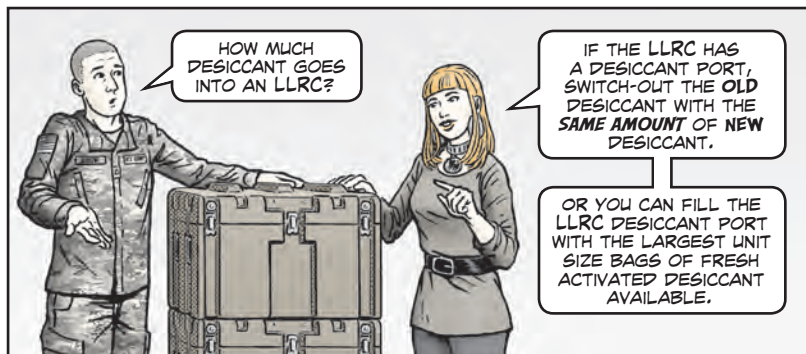

HOW MUCH DESICCANT GOES INTO AN LLRC?

IF THE LLRC HAS A DESICCANT PORT, SWITCH-OUT THE OLD DESICCANT WITH THE SAME AMOUNT OF NEW DESICCANT.

OR YOU CAN FILL THE LLRC DESICCANT PORT WITH THE LARGEST UNIT SIZE BAGS OF FRESH ACTIVATED DESICCANT AVAILABLE.

IF YOU HAVE ANY QUESTIONS ABOUT **METHOD 50**, OR CALCULATING THE AMOUNT OF DESICCANT NEEDED, EMAIL THE LOGSA PACKAGING, CONTAINERIZATION AND STORAGE CENTER (PSCC) AT: usarmy.tyad.usamc.mbx.pt@mail.mil

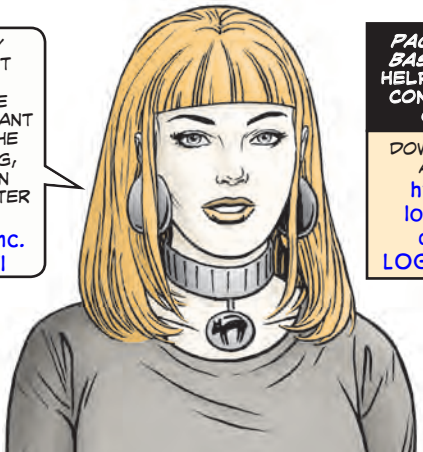

PACKAGING - THE BASICS CAN ALSO HELP ANSWER YOUR CONTAINERIZATION QUESTIONS.

DOWNLOAD A COPY AT THIS LINK: https://www.logsa.army.mil/documents/LOGSAP_746-1.pdf



Connie's POST SCRIPTS

AT422-T 22-ton Crane Intake Pipe

Get a new air cleaner intake pipe for your 22-ton crane with NSN 2940-00-107-1192. It replaces NSN 2940-01-542-1638, which is shown as Item 14 in Fig 20 of TM 5-3810-307-24P (May 07). That NSN is a terminal item.

BATTERY BOX COATING COMPOUND

Get a gallon of bituminous coating compound for your battery box with NSN 8030-00-290-5141. First use a wire brush to scrape off rust and old paint. After cleanup, protect the bare metal inside the box with a coat of the compound.

PLS A1 Engine Control Unit NSN

Order a new PLS A1 flashed or programmed C-15 engine control unit (ECU) with NSN 2920-01-643-4016. The current PLS A1 IETM only lists NSN 2540-01-565-8385, but that brings an unflashed or unprogrammed ECU.

M915A5 Radiator NSNs

There are two different radiators available for the M915A5 tractor truck. Which one you order depends on the truck's serial number. For SN AJ1134-AS8387 and AS8546-AS8961, order the radiator with NSN 2930-01-581-2109. SN AS8388-AS8545 and AS8962-AZ3356 take radiator, NSN 2930-01-597-0622.

Would You Stake Your Life ^{right now} on the Condition of Your Equipment?

AH-64 TRANSPORT HANDLE ASSEMBLY

The AH-64's transport handle assembly, NSN 1740-01-220-8472 (PN 7367311029), isn't stocked and cannot be ordered. Instead, order the transport bar assembly, NSN 1740-01-221-9436 (PN 7-367310013). That's the next higher assembly.

M915A5 Rear Wheel Seal

Get a new rear wheel seal for the M915A5 with NSN 5330-01-568-5883. It replaces PN CM 10008717, which is shown as Item 8 in Fig 138 of TM 9-2320-426-13&P in IETM EM 0308 (Aug 14). That PN doesn't cross to an NSN. Make a note until the TM is updated.

M334 Decon Kit TM Hits LIW

There's a new TM in town: TM 3-6665-439-10. It covers the M334 Decontamination Kit, Individual Equipment, NSN 4230-01-643-8267. It's also known as the Joint Service Equipment Wipe (JSEW).

Note: This TM is restricted. To view it, log in to the Logistics Information Warehouse (LIW) with your CAC at:

<https://liw.logsa.army.mil/>

Then choose the "ETM/IETM" icon and search for the TM.

M1070A1 HET Belt Tensioner NSN

The M1070A1 HET has a new, more robust belt tensioner available. NSN 2930-01-650-8617 (P/N 25278890, CAGE 0U928) replaces the belt tensioner listed as Item 32 in Fig 53 of TM 9-2320-427-13&P in IETM EM 0210 (Jan 11).

WANTED



**“Big Fist”
MURPHY**

*Disregards
torque limits!*

*Thinks a
good torque
is as much
as you can
tighten it!*

REWARD

**BETTER MAINTENANCE
AND SAFER EQUIPMENT!**

MURPHY'S LAW #27: *If a part can be
installed wrong, someone will do it.*