

Issue 803

PS

★
October
2019

THE PREVENTIVE MAINTENANCE MONTHLY

TB 43-PS-803

Approved for
Public Release;
Distribution is
Unlimited

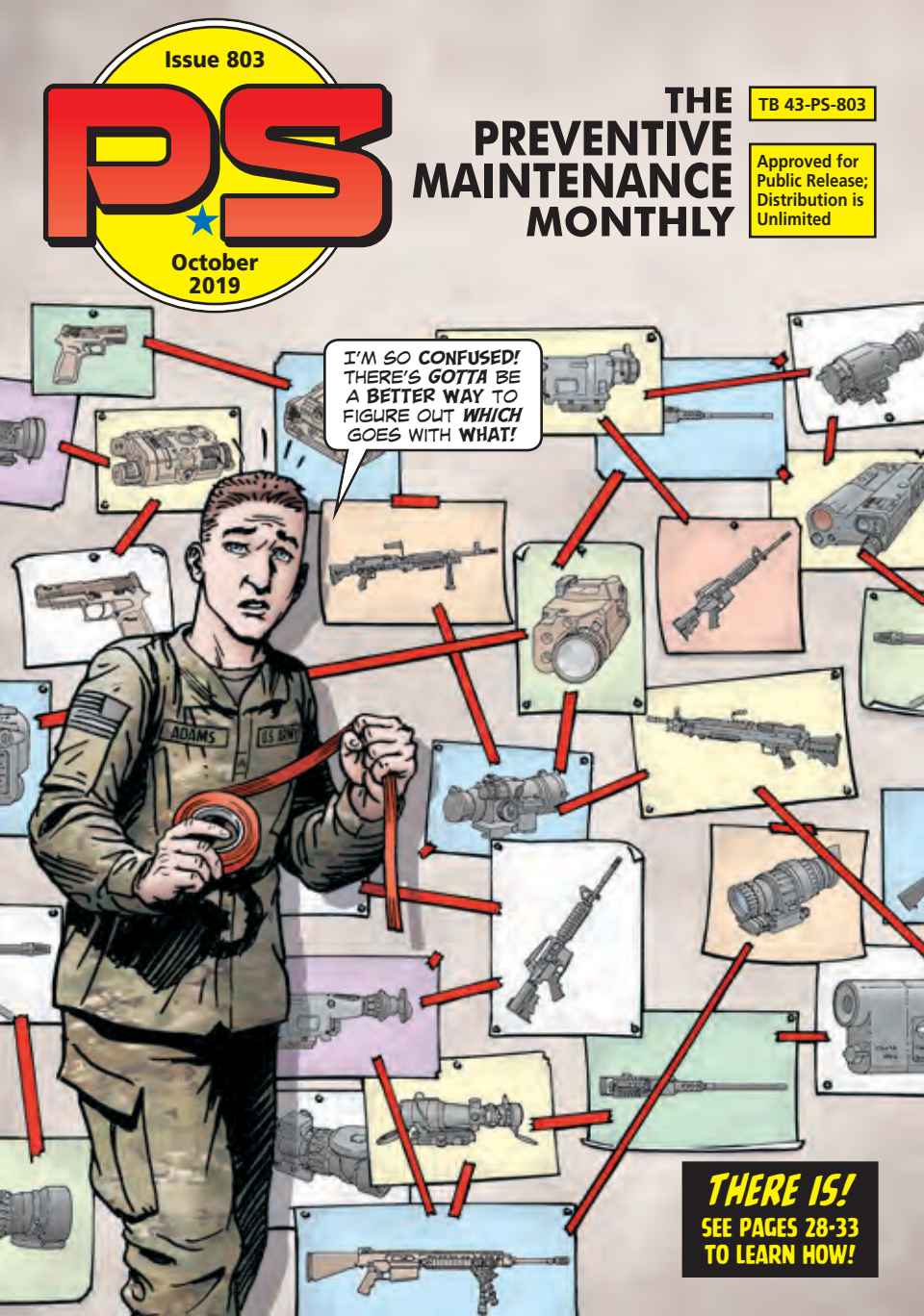

I'M SO CONFUSED!
THERE'S GOTTA BE
A BETTER WAY TO
FIGURE OUT WHICH
GOES WITH WHAT!

THERE IS!
SEE PAGES 28-33
TO LEARN HOW!



**THE
PREVENTIVE
MAINTENANCE
MONTHLY**

ISSUE 803 OCTOBER 2019



COMBAT VEHICLES 2

M88A2 Engine Fire Prevention Tips	2-3
M109A6 Paladin Cradle Mount Lube Points	4
M119A3 Howitzer, Sticking Firing Pin	5
M1-Series Tank Engine Exhaust Deflector	6
Bradley FOV DVDB Turn-in	7
Stryker Wheel Seal, Headset Repair	7, 8-9



TACTICAL VEHICLES 10

FMTV Transmission Parts, GRS Gunner's Platform	10-13
M1087A1 FMTV Mud Flap vs Splash Guard NSNs	14
M1076 PLS Trailer Dust Cap NSNs	14
Resurrecting Dead Batteries	15



CONSTRUCTION 16

966H Scoop Loader Quick-Coupler Parts	16-17
M400W Skid Loader Battery Drain Fix	17
120M Grader Door Stop Adjustment	18-19
ATLAS II Parking Brake Pad NSN	19
621G Scraper Battery Disconnect Switch	20



AVIATION 21

New H-60A/L EAWIS Resistor Improved	21
UH-72A Lakota, CPC Prevents Erosion, Corrosion	22-23
Shadow UGCS, AVT Shelter Towing Tips	24-25
UH-60A/L Internal Rescue Hoist TM	25
UH-60A/LM External Rescue Hoist Aft Cowling Mod 26	26
H-60 Series, Turn in B-Kit Assets for AN/PRC117F	27

The Right Sight Match for Your Weapon 28-33



MISSILES 34

HIMARS, MLRS Hoist Cable Checks	34
Patriot PM Tips	35-36



TOOLS 37

SECM Rain Tube, Gutter NSNs	37
UIC Changes for TMDE Calibration	38



SMALL ARMS 38

CROWS Height Clearance	38
M7 Spider Lithium Battery Safety	39
M2/M2A1 Loading Steps, M2A1 Bolt Erosion	40-41
M16 Rifle, M4/M4A1 Carbine Fit in M12 Racks	42-43
M320A1 Grenade Launcher Sight Support Cracks	44



CBRN 45

JSGP Mask, Keep Faceform and Outsert Pouch	45
--	----



COMMUNICATIONS 46

AN/VIC 3 Power Cable Arcing	46-47
ECU/FDECU Turn-in	48-49
AN/PSQ-40, CDSS, IF5 TMs	49
MEP-1030 5-kW TQG Paralleling Cable	50



SOLDIER SUPPORT 51

Security Container Combination Safety	51
Space Heater PM a Year-Round Job	52-53
Petroleum Ops Planning Smart Book	54



LOGISTICS MANAGEMENT 55

DLA's RTD Program	55-58
PSSC HAZMAT Help, CCDC-DAC Bench Stock	58
Series 200 Padlock, PSSC COSIS Training Videos	59

Connie's Post Scripts 60-61

TB 34-PS-803, *The Preventive Maintenance Monthly*, is an official publication of the Department of the Army, providing information for all Soldiers assigned to combat and combat support units and all Soldiers with unit maintenance and supply duties. All information published has been reviewed and approved by the authority responsible for the equipment, publication or policy discussed. Application of the information is optional with the user. Masculine pronouns may refer to both genders. The use of product or company names does not constitute endorsement of those products, services or companies by the U.S. Army. The use of non-DoD hyperlinks, along with their content, does not constitute endorsement by DoD or DA. Neither DoD nor DA exercises any editorial control over, and cannot vouch for, content on non-DoD websites.

PS, The Preventive Maintenance Monthly (ISSN 0475-2953)
is published monthly by the Department of the Army, Redstone Arsenal, AL 35898.

You are invited to send PS your ideas for improving maintenance procedures, questions on maintenance and supply problems and questions or comments on material published in PS.

Just write to:
MSG Half-Mast
PS, the Preventive Maintenance Monthly
USAMC ARMY SUSTAINMENT COMMAND
BLDG 3307
Redstone Arsenal, AL 35898

Or email:
usarmy.redstone.asc.mbx.psmag@mail.mil

Internet address:
https://www.aschq.army.mil/home/psmag.aspx

By Order of the Secretary of the Army:

JAMES C. MCCONVILLE
General, United States Army
Chief of Staff

Official:

Kathleen S. Miller
KATHLEEN S. MILLER
Administrative Assistant
to the Secretary of the Army
192052

DISTRIBUTION:
Distributed in electronic media only(EMO)

Click here for a copy of this article to save or email.



PS MAGAZINE – THE EVOLUTION CONTINUES, PART 1



FOR OVER 68 YEARS, PS HAS PROVIDED THE BEST MAINTENANCE AND SUPPLY INFORMATION THE ARMY HAS TO OFFER.

AND WE MEAN TO KEEP THAT MISSION GOING FOR **MANY YEARS TO COME!**

The November 2019 issue will be our last 64-page, illustrated magazine. Although “magazine” will still be part of our name, we’re **evolving** to a fully-online, mobile-friendly information portal.

The cartoons that have been part of our brand for the past 68 years will give way to **new forms** of illustration, predominately photographs and videos. Our iconic characters—particularly MSG Half-Mast—will continue to appear, although less frequently.



The primary reason is speed.
Producing a fully-illustrated magazine takes approximately four to six months to render illustrations and conduct several editing reviews for correctness.
With our new platform, turn-around time from inception to publication will routinely be days rather than weeks or months.
Look for more detail about this transformation in our November issue but wanted to give you a heads-up about these pending changes.

Fight Engine Fires with PMCS!

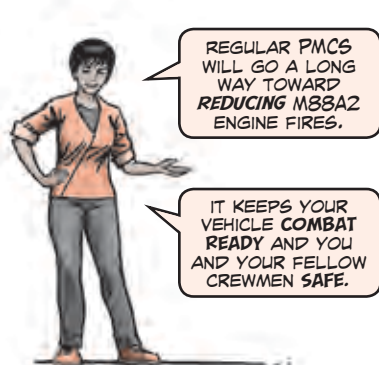
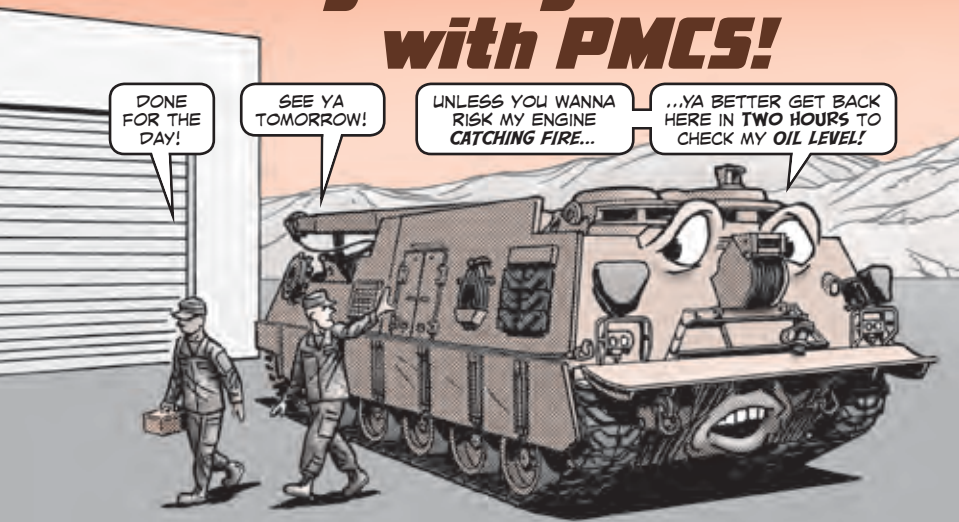

Oil Levels

Keeping a close eye on transmission and engine oil levels and staying vigilant for leaks are an important part of reducing engine fires.

Too much oil in the engine or transmission can cause as many problems as too little oil. Operating the engine or transmission with the oil level over the full mark pushes oil into the breather systems.

At the next startup, that excess engine oil is forced up through the crankcase ventilation pipe and into the turbocharger. The turbocharger's extreme heat ignites the oil and flames shoot out the right-side exhaust stack.

That's dangerous!

[Click here for a copy of this article to save or email.](#)

READ BELOW
FOR THE
RIGHT WAY
TO CHECK THE
ENGINE OIL!



Always wait at least two hours after shutdown before checking the engine oil level. That allows time for all the oil to drain back down from the engine. Sometimes operators check it too soon. Since the reading is low, they assume more oil should be added to bring the level up.

There's only one time it's OK to check the engine oil without waiting two hours after shutdown. That's during extended operations, when it's not possible to shut down the engine for that long. In that case, you can check the oil level after the engine has been idling for at least five minutes and is at normal operating temperature.

As long as the level is no more than one gallon low or one gallon high, your engine is good to go. Then do a cold check as soon as the mission allows, making sure the engine has been shut down for at least two hours.

If the oil level is too low after doing a proper check, be on the lookout for leaks. Running the engine without enough oil will do serious damage.

Ensure oil fill caps are installed and tight. Also, make sure the engine oil fill caps have rubber gaskets installed.

Check the transmission oil like it says in the -10 TM. If the oil level is low, inspect for leaks. The same goes for the auxiliary power unit (APU).

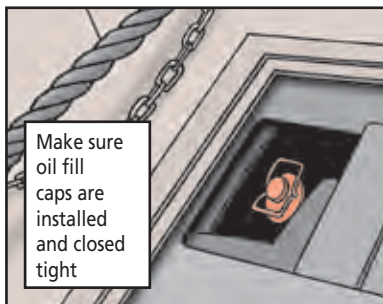

Batteries

Inspect the battery box and remove any debris. Look closely for broken or corroded supports, trays and retainers.

Make sure the battery cables don't have tears, frays or evidence of arcing such as burned areas or melted terminal boots.

The terminal connections should be good and tight, too. Finally, check the battery retainers for damage and make sure they're fastened tight.

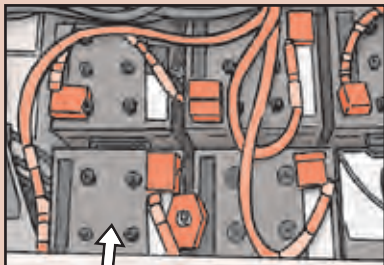

Remove any debris from battery box and check for damaged cables and retainers

Set Lube Points In Your Sights



I'VE GOT 10 LUBE POINTS ON MY CRADLE MOUNT!

SOME OF 'EM, YA REALLY GOTTA LOOK FOR -- OR ELSE WE'RE GONNA HAVE SOME PROBLEMS!

Crewmen, out of sight often means out of mind. That's not good when it comes to the hidden or hard to reach lube points on the cradle mount bearings of your M109A6 Paladin.

There are 10 lube points on the cradle mount—four inside and six outside the vehicle. The four interior lube points and the two exterior lube points on top of the cradle mount usually get lubed regularly. The four on the bottom of the cradle mount are often overlooked.

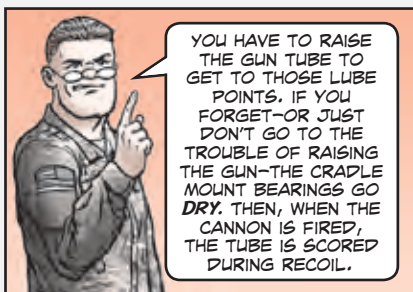
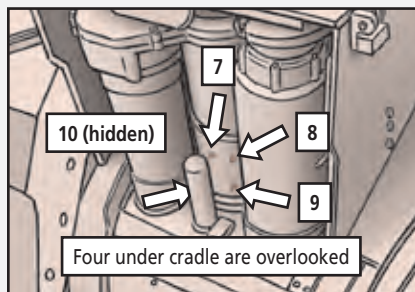
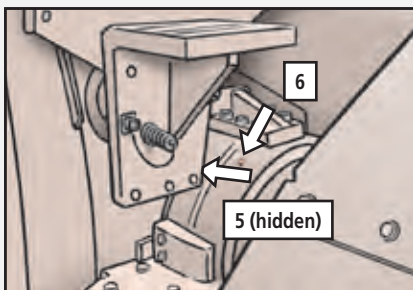
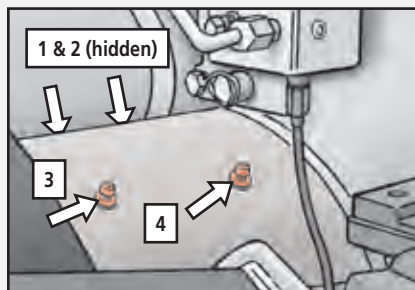

To protect the bearings, lube all 10 cradle mount lube points quarterly with molybdenum disulfide grease (GMD) or general purpose grease (GPP), following the TM's lubrication instructions operational temperature chart.

GMD comes in a 14-oz cartridge, NSN 9150-00-935-4018, or 1³/₄-lb can, NSN 9150-00-754-2595. A 1³/₄-lb can of **GPP** comes with NSN 9150-00-985-7316.

AVOID STICKY FIRING PIN!

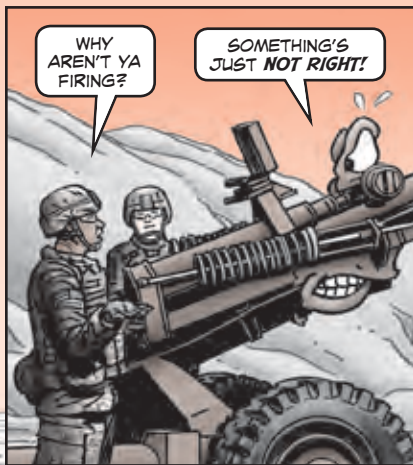

CREWMEN, IF YOUR M119A3 HOWITZER IS HAVING FIRING PIN PROBLEMS, LISTEN UP!



You can keep your howitzer firing downrange by checking that the firing pin is in place and the retaining plunger is not stuck down.

A sticking retaining plunger can cause the firing pin to rotate so the round won't fire.

Spring

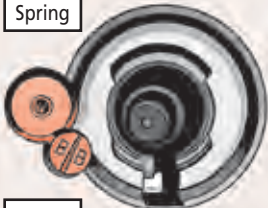

Screw

Install spring and screw in set block

Make sure that the **newest configuration spring**, NSN 5360-01-643-9517, and **screw**, NSN 5305-01-643-7398, are installed.

Installation instructions for the spring and screw are shown in WP 0102-12 of TM 9-1015-260-10 (Nov 17).



Order new spring and screw if firing pin retaining plunger is stuck down

A retrofit for the new spring and screw is nearly complete for fielded howitzers, but units should be aware that the correct NSNs for both parts aren't reflected in the RPSTL. The updated NSNs are listed above.

TOWING? DEFLECT HEAT DAMAGE!

WHAT HAPPENED TO YOU?

I GOT TOWED BACK TO THE MOTOR POOL AND THEY *DIDN'T* USE AN EXHAUST DEFLECTOR!



Crewmen, your M1-series tank's exhaust gets *seriously hot!*

THAT'S WHY WHEN ONE TANK IS TOWING ANOTHER, THE TANK THAT'S DOING THE TOWING *HAS* TO USE AN ENGINE EXHAUST DEFLECTOR.

THE DISABLED TANK CAN BE **DAMAGED** FROM THE TOWING TANK'S EXHAUST IF A DEFLECTOR *ISN'T* USED.



The deflector directs the hot exhaust from the towing tank upward and away from the disabled tank.

Without it, the exhaust can **damage** the disabled tank's vision blocks and hatch covers.

That means the disabled tank will require even **more repairs**.

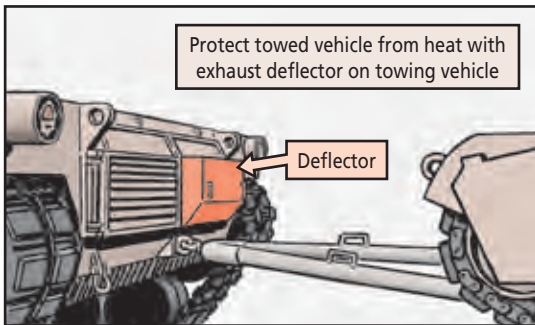

Protect towed vehicle from heat with exhaust deflector on towing vehicle

Deflector

Have your field-level maintainers make a deflector if ready-made ones aren't available. They *aren't* in the supply system. The plans are in TM 9-2350-264-23-1-8 (Jul 11, w/Ch 4, Jan 18) and TM 9-2350-388-13&P (IETM EM 0334, Jan 18).

Be sure to check out the TMs for proper towing procedures!

If you have **trouble** mounting the deflector to the exhaust grate, try **grinding down** the deflector's lower hook a bit to help it fit.

**Bradley
FOV...**

WANNA HELP
COMBAT
READINESS?

HERE'S
YOUR
CHANCE!

Turn In Unserviceable DVDBs

If you have unserviceable digital vehicle distribution boxes (DVDBs) for your Bradley, improve combat readiness and earn unserviceable credit by turning them in right away!

TACOM has a critical need for DVDBs, so turn them in through the supply system ASAP. Turning in **wired housing assembly**, NSN 5855-01-588-5668, will get your unit \$21,803 in unserviceable credit. **Wired housing assembly**, NSN 5855-01-537-1406, will also get your unit the same amount in unserviceable credit once it's updated in the system.

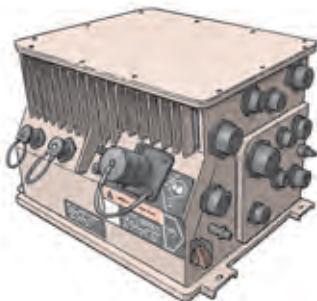

Turn in unserviceable DVDBs ASAP!

Stryker...

REPLACE SEALS, NOT WHOLE WHEEL ASSEMBLY

Dear Editor,

We've had trouble with the inner hub seals going out on the Stryker's wheel assemblies. We thought the only fix was to replace the whole wheel assembly at a cost of \$40,000 a pop. But then we discovered that just the **seals**, NSN 2530-21-906-4057, for the #1 and #2 axles can be replaced for only \$203. The procedure is in TM 9-2355-311-13&P under FRONT AXLE DRIVE SHAFT ASSEMBLY AND OIL SEAL REPLACEMENT.

Please let other Stryker repairmen know. This will save units big bucks.

SSG Michael Greene
Ft Stewart, GA

Editor's note: *You got it, Sergeant.*

Stryker...

FAULTY HEADSET? NOW HEAR THIS!

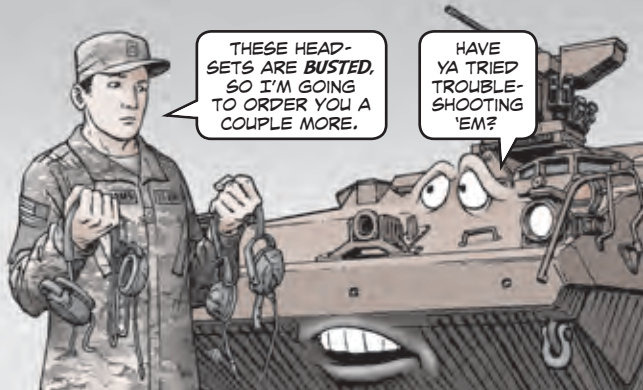

Mechanics, having a problem with the Stryker's Bose® improved tactical headset (ITH)? If so, don't be so quick to toss it aside and order a new one. Instead, save your unit money by troubleshooting and *repairing* it.

Bose improved tactical headset is repairable by field maintenance

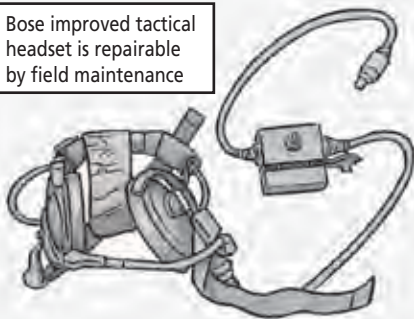

The headsets, NSN 5965-01-612-5328, cost more than \$800 each. Troubleshooting and repairing the ITH is usually easy, so give that a try instead of spending bucks when you *don't* need to!

You'll find all the info you need to maintain and repair the Bose® headsets in TM 11-5830-263-20&P (Apr 00) and TM 11-5830-274-13&P (Mar 16).

Figure out what's wrong with a faulty headset using this revised troubleshooting flow chart.

It *hasn't* been added to the TM yet.

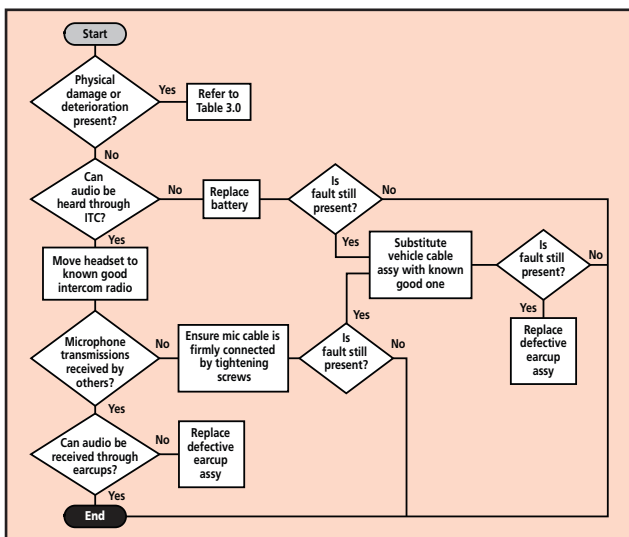

[Click here for a copy of this article to save or email.](#)

Use the following table to fix faulty components:

Components	Condition	Corrective Measures
Earcup assembly	Check for cracks and other visible damage to the housing	Replace earcup assembly
Neckband	Check for visible damage	Replace neckband
Neckband cover	Check for cuts or tears	Replace neckband cover
Over-helmet strap	Check for physical damage	Replace strap
Ear cushions	Check for visible cuts	Replace ear cushions*
Cloth scrim in earcup	Check for tears or excessive dirt	Clean or replace scrim*
Cables	Check for cuts, kinks, or frayed area on cable	Replace cable/mic assembly*
Connectors	Check for dents or other physical damage; corrosion buildup	Replace cable/mic assembly*
Battery compartment	Check for leakage, dents, corrosion buildup or other physical damage	Replace cable/mic assembly*
Microphone and boom	Check for visible damage to microphone assembly	Replace cable/mic assembly
Windscreen and O-ring	Check for damage to windscreen or missing O-ring	Replace windscreen and O-ring

*Refer to applicable removal and replacement procedure in the TM.

Here are the repair parts that are available. Note that they *haven't* been added yet to the RPSTL:

Part	NSN
Headband top	5965-01-525-1695
Headband back	5965-01-525-2635
Outer ear cushion	5965-01-525-1694
Inner ear cushion	5965-01-525-2016
Microphone harness	5965-01-525-2019
Microphone shield	5965-01-525-1684
Electrical headset	5965-01-525-1685
Cable assembly	5995-01-525-1680
Electrical cover	5930-01-525-1675

Crewmen, you can make those headsets last a LOT LONGER with preventive maintenance!

That means keeping them clean, storing them properly so they don't get stepped on or crushed by falling gear, and regularly checking them for cracks and other damage.



Headsets get damaged if not stored properly

TM Misprints Cause Transmission Misdiagnosis

Faulty solenoids Defective valve bodies Malfunctioning mode selectors Blown transmissions Bad wiring harnesses...

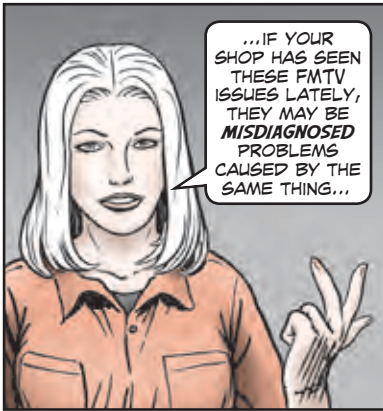

The Problem

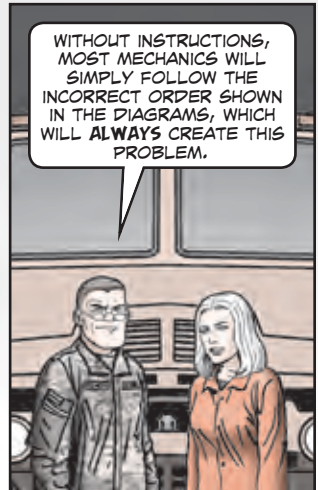
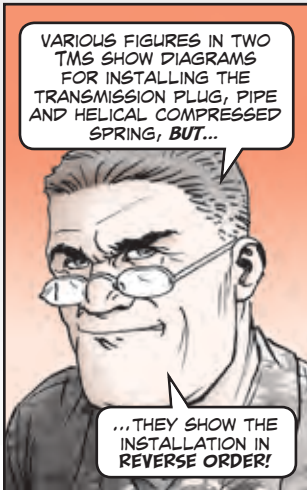

The Discovery

Mechanics at Ft Stewart, GA, discovered this when they took apart an FMTV transmission for service.

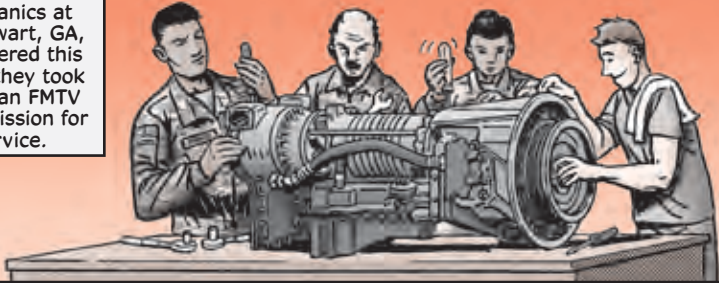

They reassembled it according to the TM diagrams...



...but the truck failed its repair inspection because...

...IT WOULDN'T SHIFT GEARS!

Further inspection revealed that the plug, pipe and spring *weren't* allowing fluid to pass through the valve body.

That caused the shift modes to lock either forward or backward without engaging the transmission mode selector, which is why the truck wouldn't shift gears.

But when the plug and spring were *reversed*, the fluid passed through the valve body and solved the problem.

The discovery was confirmed in the *Allison Transmission Troubleshooting Manual 3000/4000 Product Families (Allison 4th Generation Controls)...*



Helical spring goes into pipe plug...



...then pipe plug goes into valve body



I SHOW THE CORRECT ORDER OF THE PLUG AND SPRING!

The Fix

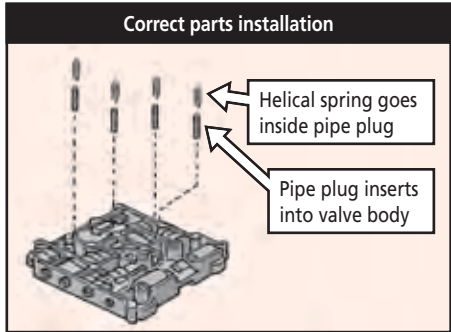
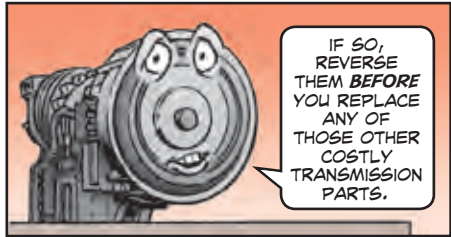
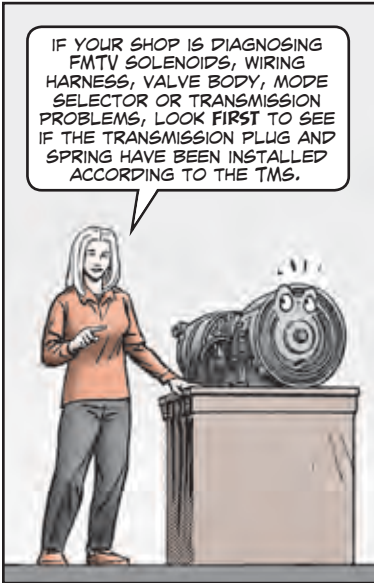

Aside from the cost of parts, improper installation due to the TM misprints costs an estimated 2.5 man-hours to correct.

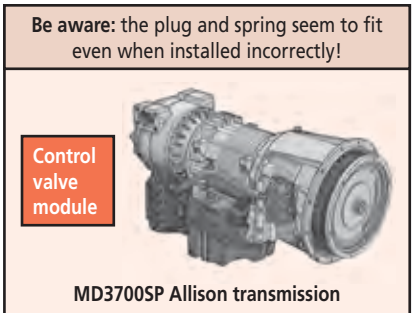
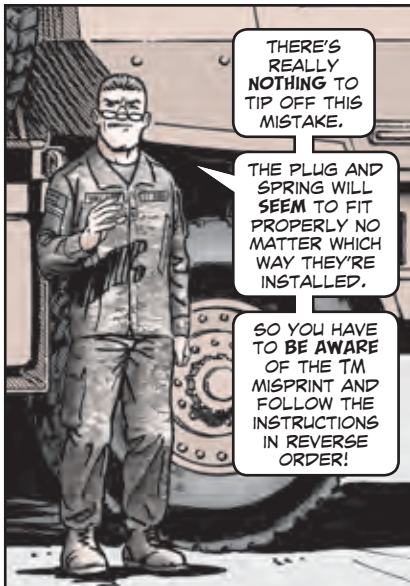

Until the TM corrections are published, the following figures should be installed in **reverse order** from what is currently shown in the TMs:

TM	Group	Fig	Items
9-2320-333-13&P	0714	142	21 & 22
9-2320-333-13&P	0714	1142	21 & 22
9-2320-391-23&P	0714	1480	22 & 50

Removal and replacement of the valve body for FMTV Gen IV Allison transmissions is moving from field level to sustainment.

All down parts, except the filter, will also be moved to sustainment level.

This will happen during the next revision of the IETM.

JUST TO CLARIFY, TRANSMISSION REPAIR AT THE FIELD LEVEL IS NOW **PROHIBITED**. UNITS CAN **ONLY** REMOVE AND REPLACE THE TRANSMISSION.

INTERNAL TRANSMISSION ISSUES SUCH AS VALVE BODY REPLACEMENT CAN **ONLY** BE DONE AT THE SUSTAINMENT LEVEL.

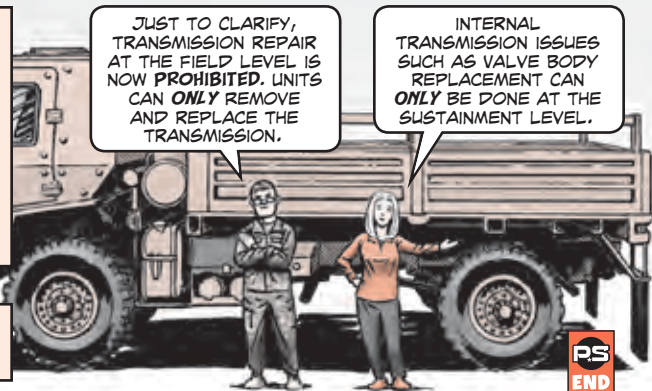

Gunner's Platform for FMTV?



AM I SUPPOSED TO HAVE A **PLATFORM** TO STAND ON WHILE I'M FIRING?

YOU BET!
PS CAN TELL YOU ALL ABOUT IT.



Dear Half-Mast,

Is there a gunner's platform for when you fire using the gunner restraint system (GRS) in an FMTV?

SSG J.B.

Dear Sergeant J.B.,

Yes, there is a gunner's platform for all AO and A1 models of the FMTV. It's part of the **machine gun mounting kit**, NSN 2540-01-570-2405. If you need instructions for mounting the kit and platform, write PS at:

usarmy.redstone.asc.mbx.psmag@mail.mil

But for the LTAS, there is no platform for a Soldier to stand on. There is a **weapons station**, NSN 2510-01-567-8727, which includes a GRS, .50-cal weapon station and the necessary hardware. The **turret hatch**, NSN 2510-01-583-8987, includes both the turret assembly and the seal interface ring for the weapons station.

Half-Mast

M1078A1
FMTV...

MUD FLAPS VS SPLASH GUARDS



It's a messy world out there. Mud flaps and splash guards can help. But not if you get the wrong ones, which has been happening with the M1078A1 FMTV!

The M1078A1 FMTV mud flaps and splash guards, shown as Items 26 and 28 of Fig 241 in TM 9-2320-391-23&P (IETM EM 0369, Oct 17), are reversed.

Item 26 shows the mud flap, but the NSN listed belongs to Item 28, which is the metal splash guard that attaches to the mud flap.

Until the TM is corrected, make a note to order the mud flaps with NSN 2540-01-377-4293 for serial numbers 100,000 and below or NSN 2540-01-525-3309 for serial numbers 100,001 and above. Order the metal splash guards with NSN 2540-01-522-1856.

Both the mud flaps and splash guards come as sets of two. And don't be confused, since they're both listed as splash guards in FED LOG.

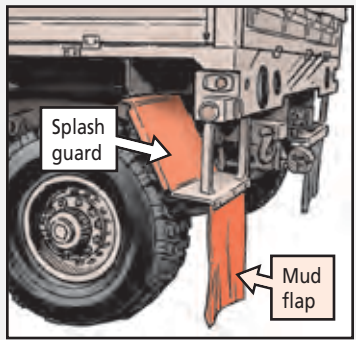

Big thanks to CW3 David Karels who caught this TM mistake!

M1076 PLS Trailer Dust Caps

Having a hard time finding an NSN for replacement dust caps on the M1076 PLS trailer's air brake chambers? That's because the newly designed air brake chambers **don't** have dust caps! For the older air brake versions, however, you'll need to order replacement dust caps with NSN 2530-01-367-6668.

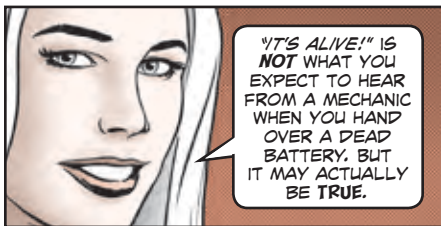

Absorbed glass mat (AGM) batteries like the 6TAGM may *seem* dead when they're really not.

It happens when a battery's voltage gets so low that it won't register on a battery charger. If you don't know that batteries sometimes play this trick, then you'll assume they're totally dead.

How can you tell? Here's a cheap and easy solution:

1. Place a good battery parallel to the dead battery, positive to positive and negative to negative.
2. Attach the charger's jumper cables to the good or bad battery, positive to positive and negative to negative.
3. Charge for about 15-20 minutes. That pushes amperage into the dead battery, raising the voltage high enough to register on the charger.
4. Remove the good battery.
5. Now charge the bad battery like you would normally.

Attach battery cables in parallel, positive to positive and negative to negative



Watch the TARDEC video on how to bring dead batteries back to life. It's on MilTube at: <https://www.milsuite.mil/video/watch/newvideo/5996>

966H Scoop Loader...

Get'cher Quick-Coupler Parts HERE!

THIS LIST OF FRONT QUICK-COUPLER HYDRAULIC LINES AND COUPLERS WILL COME IN HANDY FOR REPAIRS TO YOUR 966H SCOOP LOADER.

THANKS, JASON. IT'S MAINTAINERS LIKE YOU WHO MAKE MY JOB EASIER!



Dear Editor,

The 966H scoop loader's TM 5-3805-291-23P (Jan 10) has no listing for the vehicle's front quick-coupler hydraulic lines and couplers.

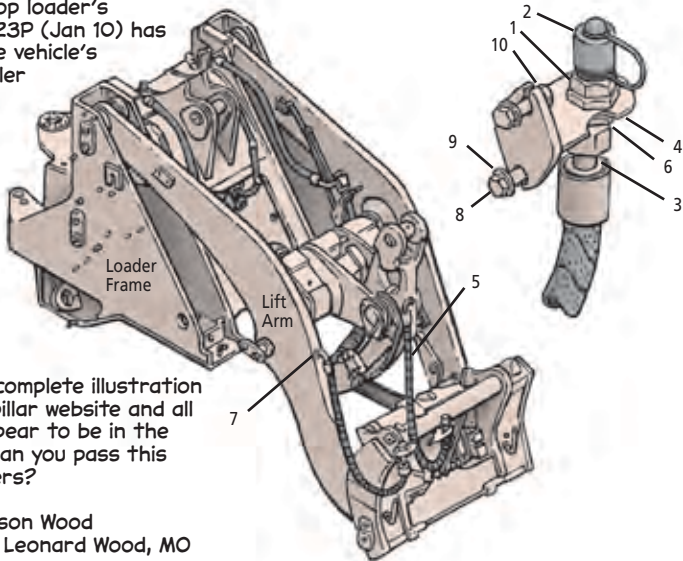

I've located a complete illustration from the Caterpillar website and all of the parts appear to be in the supply system. Can you pass this on to your readers?

Jason Wood
Ft Leonard Wood, MO

YOU BET, JASON. AND THANKS FOR THE HEAD'S UP! MECHANICS, MAKE A COPY OF THIS LIST OF COUPLERS AND QUICK COUPLER HYDRAULIC LINES UNTIL THEY'RE ADDED TO TM 5-3805-291-23P...



Item	Description	NSN	PN
1	Coupling	4730-01-290-7933	6W-2888
2	Protective cap	5340-01-563-1070	6W-2890
3	Straight adapter O-ring Seal	4730-01-630-0361 5331-01-058-4030 5330-01-626-4043	150-5430 6V-9746 163-3343
4	Bracket	5340-01-641-6878	151-2184
5	Hose assembly	4720-01-641-1777	323-9293
6	Self-locking nut	5310-01-292-8365	2P-1293
7	O-ring	5331-00-948-4063	4J-0522
8	Machine bolt	5306-01-429-3174	8T-4194
9	Flat washer	5310-01-098-0624	8T-4223
10	Hex nut	5310-01-352-7374	8T-4244

M400W Compact
Skid Loader...

IS THE DOOR SHUT?



OPERATORS, THE WORD'S OUT THAT BATTERIES ON THE M400W COMPACT SKID-LOADERS ARE KNOWN TO **DRAIN** AFTER SHUTDOWN.

A partially closed cab door is one of the most common culprits. If the door isn't shut all the way, the door's sensor stays **activated**. That **drains** the batteries, leaving no charge for the next start up!

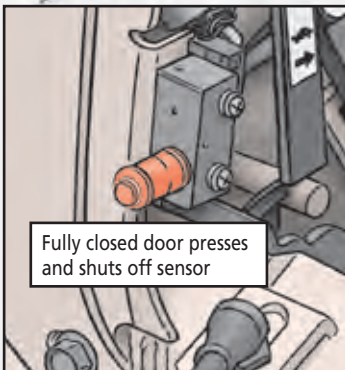

Fully closed door presses and shuts off sensor

When you close the door, make sure you hear a "click" before walking away.

That's the best way to be sure the skid-loader will start up the next time you need it.



Close door until you hear a click

STOP UPPER DOOR STOP BENDS

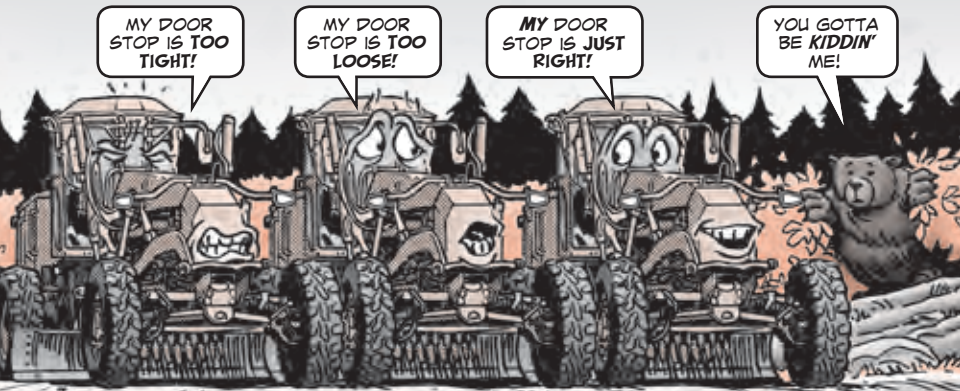

Operators, opening and closing the 120M grader's cab door can bend the door stop, especially if the stop is out of adjustment.

The door stop assembly has to be adjusted just right. If adjusted too far out, the door hits and bends the stop downward. And if the stop is adjusted too far in, the bottom of the door hits the catch and bends outward.

That puts a lot of stress on the door. A bent stop can hit the window instead of the door frame. Replacing a cracked window will set you back \$850. A new door runs about \$1,158. That's a lot of dough to throw down the drain!

If not adjusted, door stop bends over time

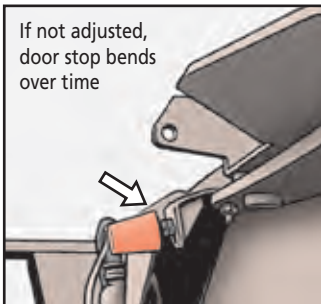

You can avoid wasting money with this simple adjustment:

1. Use a 1/2-inch open end wrench to loosen the hex nut on the door stop.
2. Adjust the door stop by screwing the rubber knob in or out. Some trial and error will be needed to get the door stop just right. It should connect with the upper door frame without allowing the bottom of the door to hit the catch.

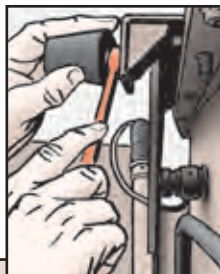

3. Once the stop is properly adjusted, tighten the hex nut to hold it in place.

Once adjusted, tighten nut with 1/2-in wrench

[Click here for a copy of this article to save or email.](#)

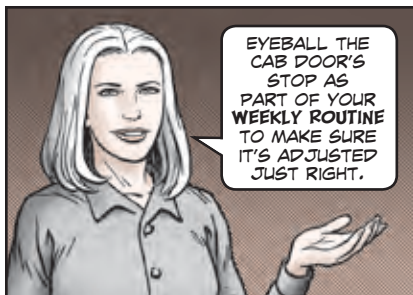

EYEBALL THE CAB DOOR'S STOP AS PART OF YOUR WEEKLY ROUTINE TO MAKE SURE IT'S ADJUSTED JUST RIGHT.

By the way, **don't** look in TM 5-3805-293-10 or -23 for this door stop adjustment.

IT'S **NOT** IN THOSE TMS YET. BUT INSTEAD, FOLLOW THE STEPS IN THIS ARTICLE.



ATLAS II Forklift...

Right Scoop on Parking Brake Pad

MY PARKING BRAKE IS **WORN OUT!** WHY DON'T YOU REPLACE IT?

I TRIED, BUT THE PARTS KIT I ORDERED **DIDN'T** HAVE WHAT I NEEDED!

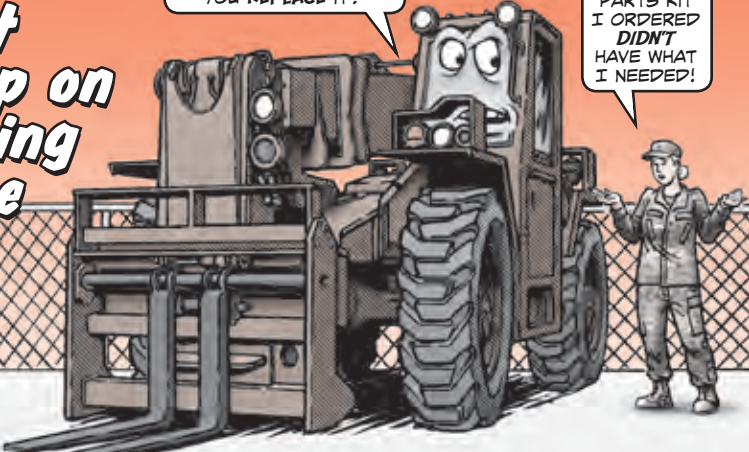

Mechanics, you may run into problems when ordering new parking brake pads for the ATLAS II forklift.

Items 4 and 15 in Fig 111 of TM 10-3930-677-23&P (IETM EM 0359, Aug 16) are the items in question. Item 4 says it's a grommet retainer when it's actually a retainer screw. And both Item 4 and 15 say they're components of parts kit, PN MPS4009. That's not true.

To get the parking brake pads, order NSN 2530-00-167-9457. Note that the NSN only brings one pad. You'll need to order two of the pads for the parking brake.

It very rarely happens, but if you need a new retaining screw, order it on a DD Form 1348-6 using part number 3105A1171 and CAGE 60250.



Order **one** brake pad with NSN 2530-00-167-9457

SAVE POWER FOR WHEN YOU NEED IT



If your 621G scrapper has been sitting for a long time, it may *not* start when you need it. The batteries in these vehicles are known to drain if they sit too long without a start.

No juice means you're going *nowhere*—at least not until help arrives for a slave start.

So after the day's run, make sure you use the vehicle's battery disconnect switch. It cuts off all flow from the batteries, so you'll have the power you need for that next start.

The battery disconnect switch is located at the front of the vehicle behind the engine panel on the right side. Simply flip back the switch's cover and use the key to switch the disconnect to the STOP position.

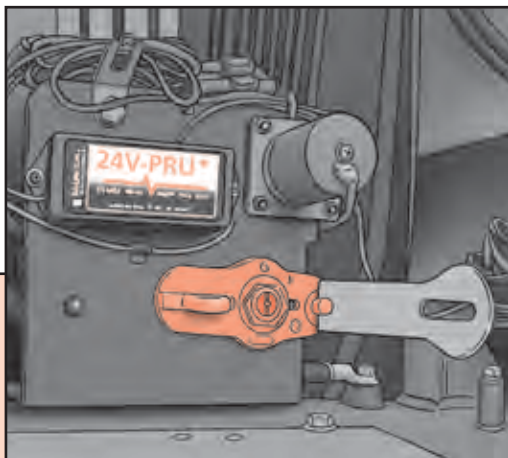

Of course, you'll need to **remember** to turn the switch back down to the run position *before* trying to start the scrapper again.

Otherwise, you won't get *any* power at all!

New Resistors Improve Encrypted Wireless Intercom Performance!



LISTEN UP,
EVERYBODY. WE'RE
GONNA GET NEW
RESISTORS!

WHAT'D
HE SAY?

Pilots, a
new resistor
configuration
is now available
for the
H-60A/L!

It allows the aft crew to hear the aircraft radios turned down to almost zero when using the encrypted aircraft wireless intercom system (EAWIS).

THIS
IS A
PRETTY
BIG
DEAL!

After all, the *current* configuration *doesn't* allow the radios to drop below about 80 percent before the aft crew can't hear them anymore. That's annoying to the pilots since the radios are competing for attention all the time at higher volumes.

The upgraded radio resistors not only improve audio performance, but also provide better clarity for EAWIS users. And an electrician can install the new resistors in less than an hour.



Though the headshed recommends installation of the new resistor modules (PN TJSE20863 and PN TJSE20553), it *isn't* mandatory. PM Air Warrior will only provide the replacement resistors to UH-60A/L aircraft units that have the EAWIS installed.

Resistor, 16 Ohms
PN: TJSE20863
Qty: 1



Resistor, 1K Ohms
PN: TJSE20553
Qty: 1



To get the resistors, contact Carrie Ducharme, (256) 842-3826 or email: carrie.a.ducharme.ctr@mail.mil

UH-72A
Lakota...

LOOKS LIKE
YOU'VE GOT SOME
CORROSION THERE,
BUDDY.

SOMEBODY
OUGHTA DO
SOMETHING
ABOUT THAT.

THAT SOME-
BODY IS YOU,
SOLDIER!

CONTROLLING EROSION AND CORROSION IS **YOUR** RESPONSIBILITY



MECHANICS, THE
LAKOTA MAY BE
A CONTRACTOR
LOGISTICS
SUPPORTED
ROTARY WING
AIRCRAFT, BUT
MAINTAINERS ARE
RESPONSIBLE FOR
ALL INSPECTIONS
AND SERVICES...

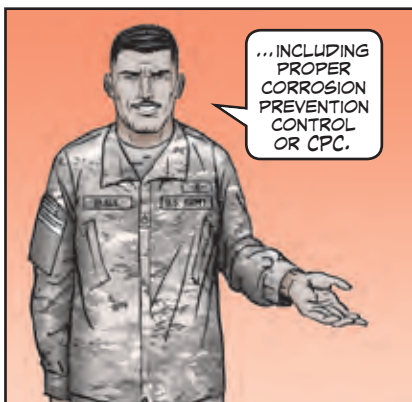

...INCLUDING
PROPER
CORROSION
PREVENTION
CONTROL
OR CPC.

The areas of focus for corrosion prevention are listed in Chap 9 of the Maintenance Compliance Inspection (MCI) checklist, *Corrosion Prevention Control Policy*. They include:

- unit SOP
- Aircraft Notebook (ACN)
- historical record documentation
- maintainer training certification

[Click here for a copy of this article to save or email.](#)

Lakota units need to follow Army guidance and use the original equipment manufacturer (OEM) guidelines to control and prevent corrosion problems.

The OEM guidelines are found in MBB-BK-117, *Corrosion and Erosion Control Guide (CECG)*, and the *Standard Practices Manual-Corrosion Inhibiting and Removal Procedures*.

The CECG provides checks and procedures that will improve aircraft corrosion and erosion prevention, based on geographic location.

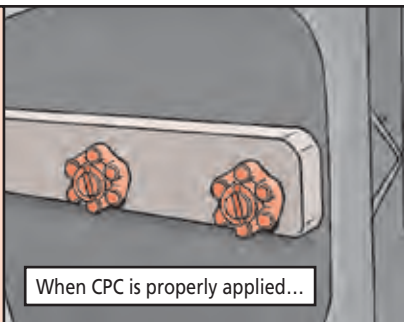

...corrosion and erosion *won't* form

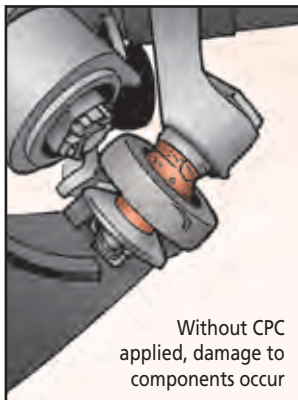
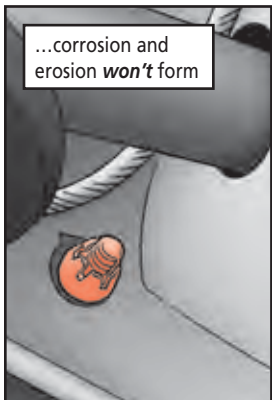

Without CPC applied, damage to components occur

If you find corrosion on an aircraft component, you'll need to follow the OEM's *Standard Practices Manual-Corrosion Inhibiting and Removal Procedures* outlined in Chapter 20-04-03-401.

Reapplying corrosion prevention compounds contained in the manual helps **protect** those components.

Be aware that **any** component needing replacement because of corrosion *isn't* covered under the Contractor Logistics Support contract.

Corrosion prevention is considered the unit's responsibility!

So **any** damage to a component from corrosion is an **over and above** contract action cost to the government and may be paid by the **unit**.



Over and above includes the component cost, shipping and handling, and any additional processing fees. So save your unit time and effort by following the proper CPC practices!

TOW HITCH NO LICENSE FOR UNLIMITED TOWING

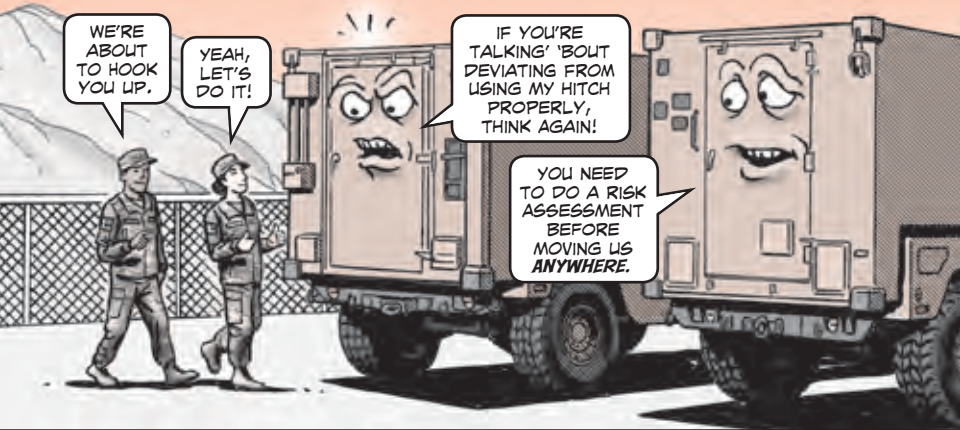

Shadow operators, just because your universal ground control station (UGCS) and air vehicle transport (AVT) shelters have tow hitches doesn't mean there's zero risk in using them for towing.

Proper operation of the Shadow's UGCS and AVT shelters is a must. If not, you may pay a heavy cost in damaged equipment, including what's loaded inside. So be forewarned.

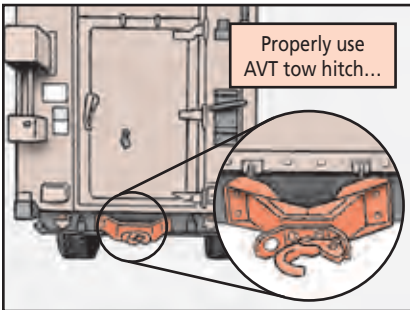

Properly use
AVT tow hitch...

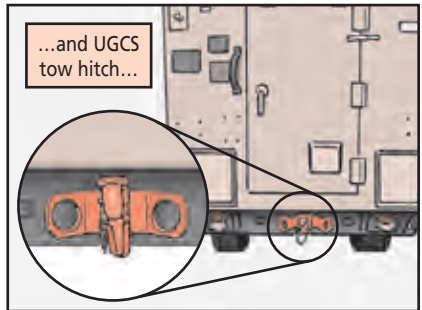

...and UGCS
tow hitch...

...for trailer towing unless commander approves deviation after risk assessment

Never load a vehicle beyond the manufacturer's listed gross vehicle weight rating (GVWR). You can find the correct weights in the DA Transportability Approval document, DP12-13 (22 Jan 16).

Once you've packed the UGCS and AVT shelters according to TM 1-1550-1689-23&P, they're already at the maximum GVWR. So stop there. Loading additional equipment can damage the HMMWV's axle and transmission.

Prior to moving equipment, make sure your commander knows about any deviation in trailer towing so that a risk assessment can be made.

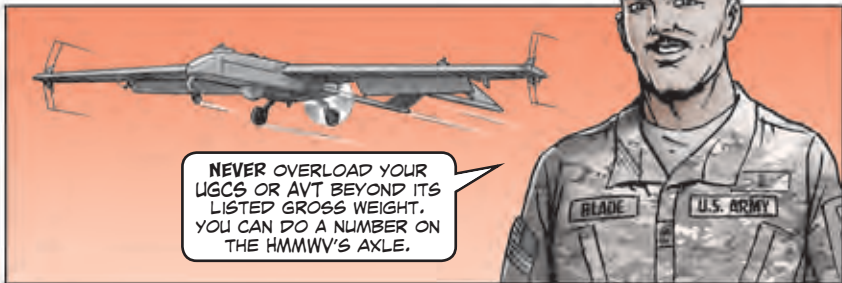

UH-60A/L...

MECHANICS, TM 1-1680-320-13&P, UH-60A/L HIGH PERFORMANCE RESCUE HOIST, NSN 1680-01-552-3442, IS REVISED AND AVAILABLE FOR USE.

Internal Rescue Hoist TM Published

The revised TM includes more troubleshooting procedures, corrected schematics, additional maintenance procedures and other updates.

If you work on the internal rescue hoist, make sure you use the good info in the revised TM 1-1680-320-13&P (Nov 18). And if you find any problems, send an email to the POCs in PD MEDEVAC. Contact Michael Brooks or Dave Dapkus at:

michael.w.brooks28.civ@mail.mil
david.b.dapkus.ctr@mail.mil

THE REVISED TM ON THIS INTERNAL RESCUE HOIST TM HAS LOTS OF NEW INFORMATION.

USE IT FOR DAILY PMCS AND MAINTENANCE.

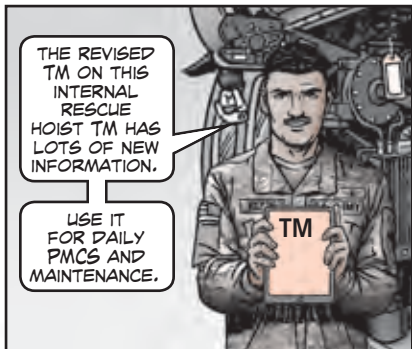

[Click here for a copy of this article to save or email.](#)

H-60A/L/M...



TO GET THE EVENT COUNTER VIEWING WINDOW MOD DONE, CALL YOUR LAR AND LIAISON ENGINEER.

IF THE UNIT PERFORMS THE MOD, ORDER SOME EXTRA FAIRINGS TO HAVE ON-HAND.

HOIST MOD **APPROVED** FOR EVENT COUNTER VIEWING WINDOW



MECHANICS, AVIATION ENGINEERING DIRECTORATE LIAISON ENGINEERS—OR AED LEs—NOW HAVE PERMISSION TO MODIFY THE MEDEVAC'S EXTERNAL RESCUE HOIST, NSN 1680-01-505-3913, AFT COWLING.

MEDEVAC units who want to apply the fairing modification must work through their logistics assistance representative (LAR) and liaison engineer (LE) for a maintenance engineering call (MEC) authorization letter.

If you *don't* have access to a servicing LE, email AED directly at: usarmy.redstone.rdecom-amrdec.mbx.ae-u-tts@mail.mil

If units decide to perform this modification, it's also a good idea to purchase a couple of *extra* fairings to keep on hand.

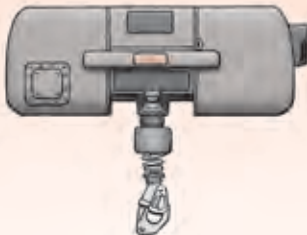

That way, if you need to turn in a hoist to supply, you can *keep* the modified fairing, which is:

AFT Cowling, PN BL-14658-1, CAGE 08484 (Breeze-Eastern LLC).

H-60 Series...

WE'RE WAITING
HERE FOR
EXTRACTION.

THIS IS THE **LAST**
TIME WE USE THIS
RADIO SET. WE'LL
HAVE TO TURN IT
IN WHEN WE GET
HOME.

Turn in AN/PRC-117F in SATCOM B-Kits

If you have aircraft in your unit with the AN/PRC-117F SATCOM MWO applied, the AMCOM headshed needs you to turn in the B-kit assets.

The B-kits are needed for overseas contingency operations requiring SATCOM, so round up all you can find and turn them in **ASAP**.

The PRC-117F radio system can **no longer** be purchased, so B-kits are only available if they're turned in.

PRC-117F radio system can no longer be purchased



Here's a list of equipment for turn-in:

Item	NSN	CAGE	PN	Qty
AN/PRC-117F radio set	5820-01-462-2484	14304	10513-0500-011	1
KDU extension cable	6145-01-461-5300	14304	10511-0704-012	1
Transceiver power unit	6130-01-493-6643	08TP4	ABP-AC/DC/BT-TR-1	1

If you have this equipment, contract the UHPO property book POC:
Eric Zurowski,
(256) 313-1310.

Or email:
eric.b.zurowski.civ@mail.mil

The return address for shipment is:

DODAAC: W913TV
AMCOM FSRD Distribution Center
Bldg. 8024
Cottonwood Rd
Attn: Gary Williams, (256) 955-9638 (RECAP)
Mark for: Eric Zurowski, (256) 313-1310
Redstone Arsenal, AL 35898

THE RIGHT SIGHT MATCH FOR YOUR WEAPON

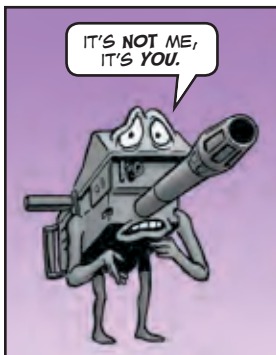
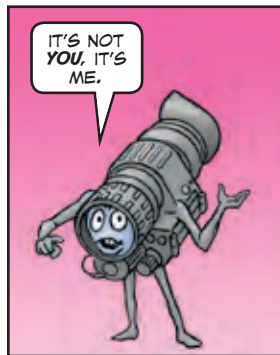
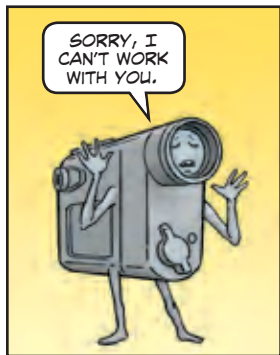

The Army gives Soldiers *all sorts of choices* for sights, lasers and infrared illuminators to use on their rifles, pistols and machine guns.

But it can be **difficult** to tell what can be used where and how to find info on mounting and using a device.



Here's a list of sights, their NSNs and TMs, along with what weapons they can be used on:

**AN/PEQ-15 multi-functional aiming light:
NSN 5855-01-537-6000 (family) (LIN J03261):**

AN/PEQ-15 (tan), NSN 5855-01-577-7174
AN/PEQ-15 (black), NSN 5855-01-534-5931

**Both are covered by
TM 9-5855-1914-13&P.**

The AN/PEQ-15 can be used on the:

- M16-series rifle
- M4/M4A1 carbine
- M249 machine gun
- M240B machine gun
- M2 machine gun
- MK 19 machine gun

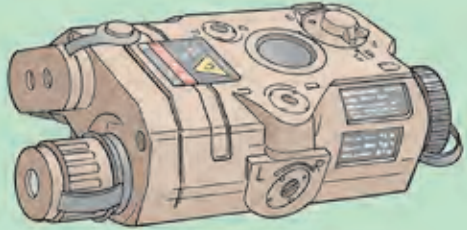

**AN/PEQ-14 integrated laser white light pointer (ILWLP)
(LIN J68403):**

AN/PEQ-14 (tan), NSN 5855-01-571-1258
AN/PEQ-14 (black), NSN 5855-01-538-0191

Both are covered by TM 9-5855-1911-13&P.

The AN/PEQ-15 is used *only* on the M9 pistol in MP units.

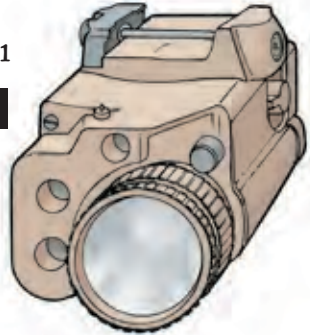

**MX-12597/U pistol aiming laser:
NSN 5855-01-679-4066**

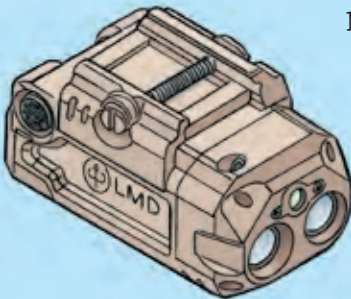

It has no TM. The enhancer is used with the new M17/M18 pistol.

Laser borelight system (LBS):

AN/PEM-1 (L05005), NSN 5860-01-471-2091, TM 9-5860-226-13&P

The AN/PEM-1 is used on all small arms and is authorized through the CTA.

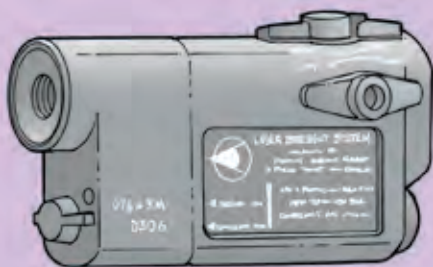

AN/PSQ-23 small tactical optical rifle mounted (STORM) micro laser range finder (MLRF) (LIN J68653):

AN/PSQ-23 (tan), NSN 5855-01-577-5946, TM 9-5855-1913-13&P

AN/PSQ-23 (black), NSN 5855-01-535-1905, TM 9-5855-1913-13&P

AN/PSQ-23A, NSN 5855-01-600-0486, TM 9-5855-1820-13&P

AN/PSQ-23B, NSN 5855-01-646-5962, TM 9-5855-1922-13&P

The AN/PSQ-23 STORM is used on all individual and crew served weapons, plus the M110 sniper system...

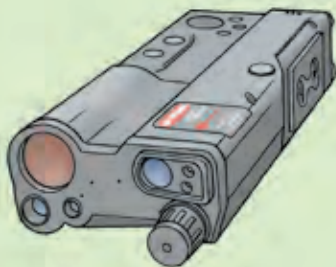

...AND THE STRYKER REMOTE WEAPONS STATION!

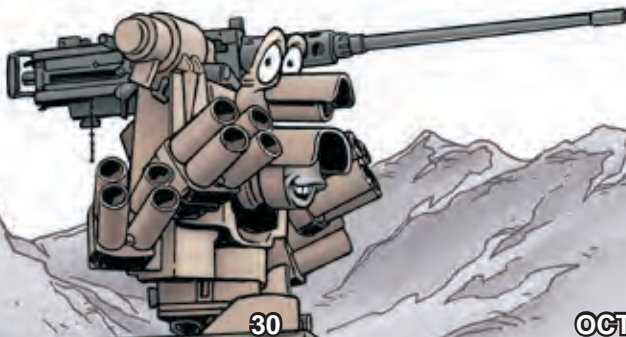

AN/PAS-13 light weapon thermal sight (LWTS) (LIN S60356):

AN/PAS-13C(V)1, NSN 5855-01-523-7707, TM 11-5855-316-10

AN/PAS-13D(V)1, NSN 5855-01-524-4308, TM 11-5855-324-10

AN/PAS-13E(V)1, NSN 5855-01-561-0057, TM 11-5855-325-10

AN/PAS-13G(V)1, NSN 5855-01-600-2717, TM 11-5855-331-10

The LWTS can be used on the:

- M16-series rifle
- M4/M4A1 carbine
- AT4

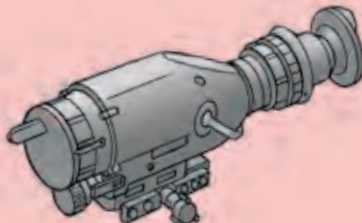

AN/PAS-13 medium weapon thermal sight (MWTS) (LIW S90535):

AN/PAS-13C(V)2, NSN 5855-01-523-7713, TM 11-5855-316-10

AN/PAS-13D(V)2, NSN 5855-01-524-4313, TM 11-5855-317-10

AN/PAS-13E(V)2, NSN 5855-01-561-3801, TM 11-5855-325-10

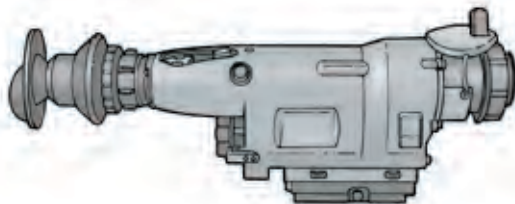

All versions of the MWTS can be used on the:

- M16-series rifle
- M4/M4A1 carbine
- M240-series machine guns
- M249 machine gun

AN/PAS-13 heavy weapon thermal sight (HWTS) (LIW S90603):

AN/PAS-13C(V)3, NSN 5855-01-523-7715, TM 11-5855-316-10

AN/PAS-13D(V)3, NSN 5855-01-524-4314, TM 11-5855-317-10

AN/PAS-13E(V)3, NSN 5855-01-561-5343, TM 11-5855-317-10

All versions of the HWTS can be used on the:

- M16-series rifle
- M4/M4A1 carbine
- M2 machine guns
- MK 19 machine gun
- M24 sniper rifle
- M107 sniper rifle

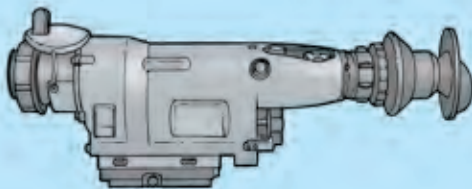

AN/PVS-29
night vision sight:
NSN 5855-01-567-9243,
TM 9-5855-1916-13&P

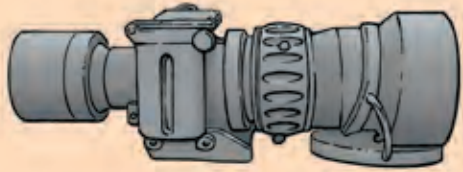

AN/PVS-30
night vision sight:
NSN 5855-01-567-9243,
TM 9-5855-1916-13&P

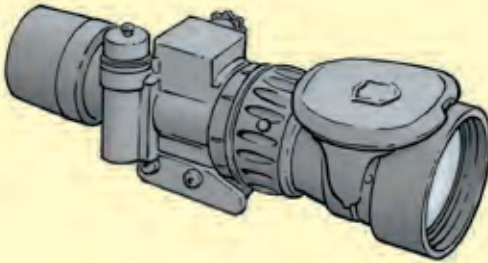

THE AN/PVS-29 AND AN/PVS-30 ARE
USED **ONLY** ON THE M110 SNIPER SYSTEM.



AN/PVS-14 monocular night vision device (LIN M79678):
NSN 5855-01-432-0524, TM 11-5855-306-10

The **AN/PVS-14** is used on the M16A2 rifle, where it's mounted behind the M68 sight.

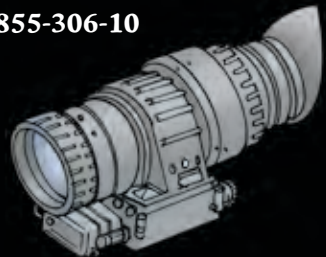

Reflex sight, M68 close combat optic (CCO) (LIN S60288):
M68 CompM4S, NSN 1240-01-576-6134, TM 9-1240-413-13&P

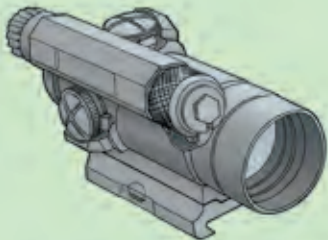

The **M68 CompM4S** can be used on the M16-series rifle and the M4/M4A1 carbine.

M150 Rifle combat optic (RCO) sight (LIN S45729):
NSN 1240-01-557-1897, TM 9-1240-416-13&P

The **M150** can be used on the:

- M16-series rifle
- M4/M4A1 carbine
- M249 machine gun

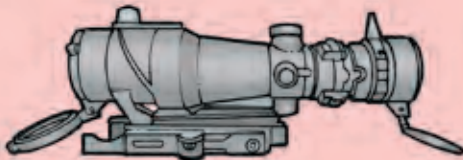

M145 straight telescope (LIN T60185):

NSN 1240-01-411-6350,
TM 9-1240-415-13&P

The **M145** is used on the M240-series machine gun.

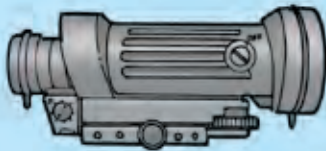

ANY TIME YOU HAVE QUESTIONS ABOUT WHAT YOU **CAN** AND **CAN'T** USE ON YOUR WEAPON, CHECK OUT THE **SMALL ARMS INTEGRATION BOOK**, WHICH CAN BE ACCESSED AT:

<https://www.ako1.us.army.mil/suite/folder/4718898>

PS
END

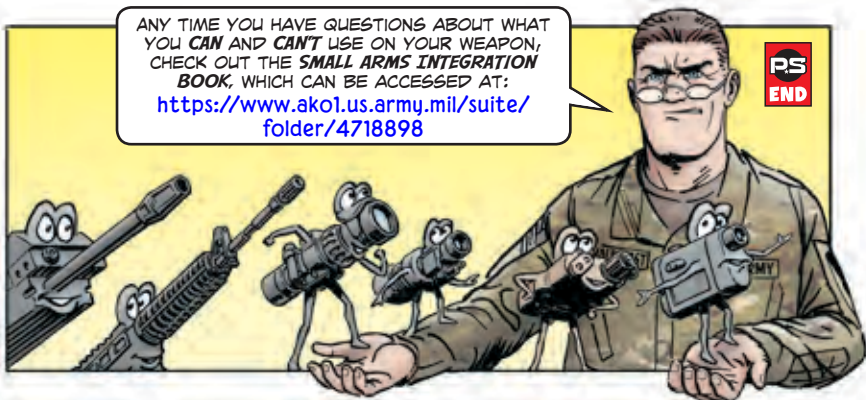

Keep Hoist Cables Hoisting

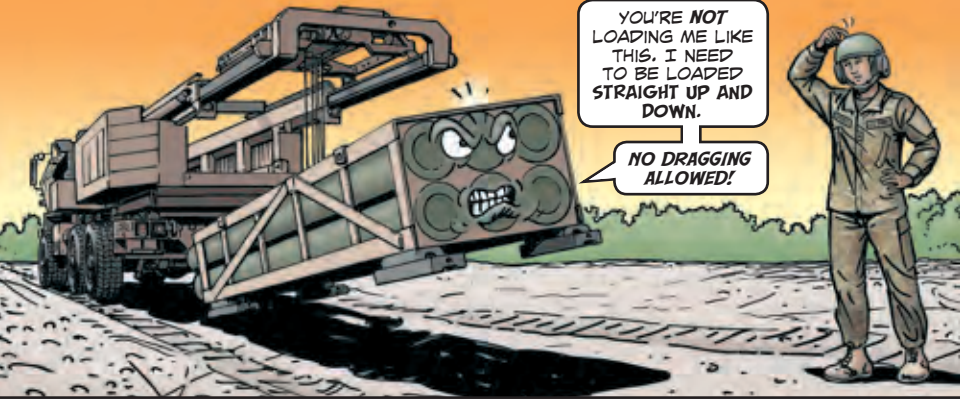

If the HIMARS or MLRS hoist cables can't do their job, your rocket firing will be pretty much one-and-done. No hoist cables mean no loading rocket pods. Your HIMARS or MLRS has just turned into expensive transportation.

That's why it's so important HIMARS/MLRS crews pay attention to the hoist cables *before* they go to the field. Spot problems while they're easy to fix.

Visually inspect hoist cable for broken wires, kinks, bulges or birdcaging, flat worn surface and unusual scrape marks. The cable is no good and must be replaced when there are six randomly distributed broken wires in one rope lay or three broken wires in one strand in one rope lay. Broken wire count should be made at the worst strand at the worst section of the cable. If it breaks during operation, you could even lose the hoist drum. Plus, a cable that snaps can whip out and remove an eye. If you have any doubts about a hoist cable, tell your repairman.

Of course, the main reason hoist cables get in bad shape is that crews drag rocket pods during loading. That's a sure cable killer.

The rule to hoist by is to lift and lower rocket pods straight up and down, keeping tension on the cable. If there's slack in the cable, it can slip off the hoist pulley.

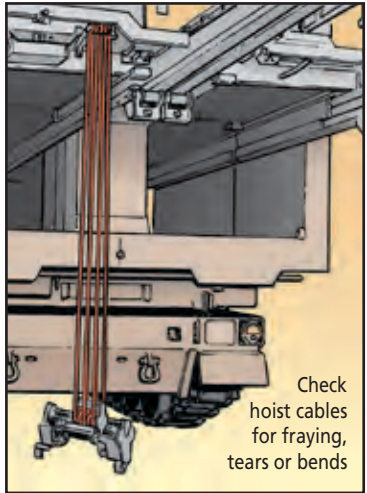

The MLRS and HIMARS TMs are specific about how far the hoist hook can be from the hoist lifting bars:

- **MLRS**—15.9 inches, the width of the hoist hook and pulley assembly.
- **HIMARS**—8 inches, half the width of the hoist hook and pulley assembly.

If the distance is **more** than that, reposition the hoist. *That's* how you save hoist cables!

PATRIOT HELP

FROM FT BRAGG

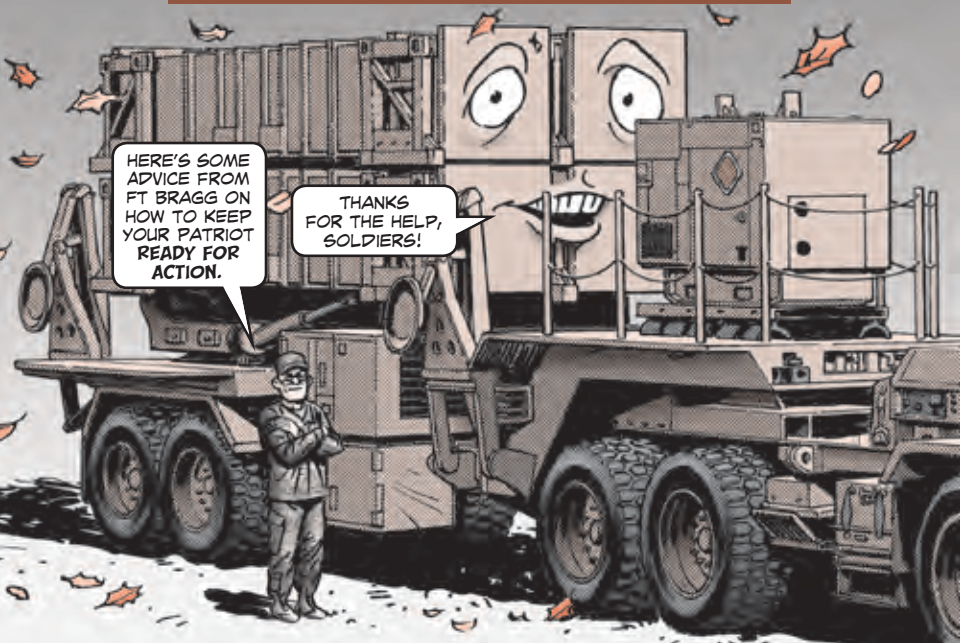

Dear Editor,

While keeping Ft Bragg's Patriot batteries ready for action, we've come up with a few tips to help other Patriot units:

- **Drain the PAC-2 launching station LMRD and the PAC-3/MSE launching station J-box/LSDU at least weekly. Drain daily in humid areas.** We've had trouble with moisture collecting in the boxes and causing major electrical damage, as in hundreds of thousands of dollars. It takes only five minutes to drain them, so to say the least, it's worth the extra time.

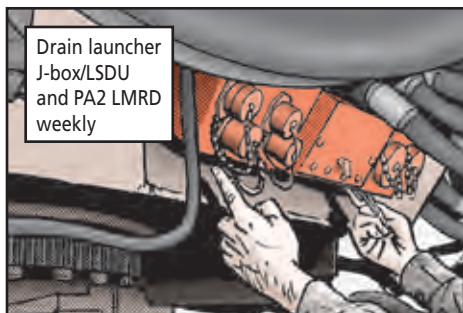

- **Don't force the fiber optic cables that run from the ECS to the launcher.** Sometimes the cable connectors don't want to turn when you unscrew them. But forcing them breaks the connector's glass ferrules. Then the connector has to be replaced. Help connectors turn by lubing the connector and jack threads with a spray lubricant like NSN 6850-00-838-7789. This NSN brings a box of 12 16-oz cans.

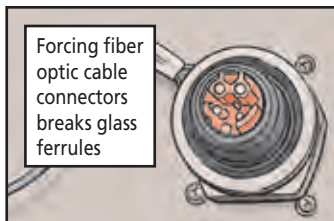

- **Keep your feet off the launcher J4, J10 and J11 cables.** During timed drills especially, Soldiers sometimes step on the cables as they rush through their tasks. That can break a cable's wiring, which usually means replacing the cable.

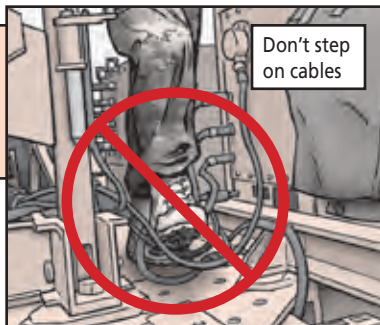

- **Launcher switch trips? Check voltage first.** If the PAC2 LEM 28VDC switch flips to the center position when you power up the launcher, check the generator's output before doing any trouble-shooting. It should be 400 hertz and 208 volts. If it isn't, adjust the generator and try again. That often solves the problem.

Lube feed horns monthly

- **Lube the AMG feed horns monthly.** The antennas are often left erected for long periods, which means corrosion can lock up the feed horns. Sometimes the only fix is to replace the whole antenna. So lower the antennas at least once a month and lube the feed horns with spray lubricant, NSN 6850-00-838-7789.



- **Keep the launching station actuator arms covered when you're not operating.** The arms have a cover, but they often disappear or get in such bad shape they do little good. Then the arms have no protection from the elements. If the covers disappear or wear out, cover the arms with tarps. Order more covers with NSN 1420-01-354-9685.

Keep actuator arms covered



CW3 Trenard Conyers
 CW2 Diana Peters
 SFC Joseph Evans
 SGT Kenneth Hickman

Editor's note: *These are indeed Patriot tips to salute. Thanks.*



Get Parts for a Rainy Day

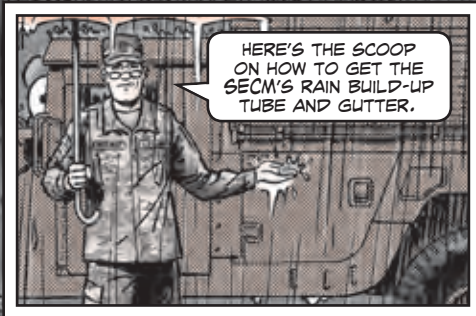

Dear Half-Mast,

Our unit needs help finding NSNs for some parts on the shop equipment, contact maintenance (SECM) truck.

First is the **rain build-up tube**, NSN 4710-01-619-6151. It's shown as Item 13 in Fig 2 of TM 9-4940-574-13&P, but the NSN is a terminal item. Is there a replacement NSN?

Second is the rain gutter shown as Item 15 in Fig 2. It has a part number (11B363073) and CAGE (59678), but they don't cross to an NSN on FED LOG. Is there a good NSN?

SFC G.K.W.

Dear Sergeant,

Here's the scoop on those SECM parts:

The NSN for the rain build-up tube was cancelled and replaced with two new NSNs. Order NSN 4710-01-642-6841 to get a **build-up tube for the rain gutter** and NSN 4710-01-642-6842 to get the **build-up tube for the floor pans**.

As for the rain gutter itself, there is no NSN. If you need one, you can fabricate it from aluminum sheet metal. For a drawing and instructions, email the SKOT group at:

usarmy.detroit.tacom.mbx.ilsc-skot-group-actions@mail.mil

Half-Mast



How to Change UIC for TMDE

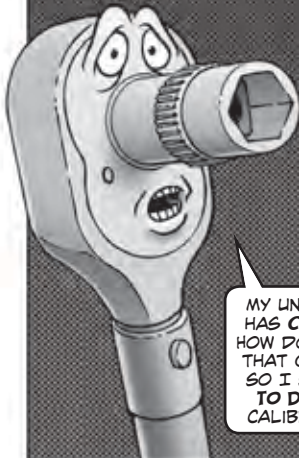

MY UNIT'S UIC HAS CHANGED! HOW DO WE GET THAT CHANGED SO I STAY UP TO DATE ON CALIBRATION?

Dear Half-Mast

I help support several units as their TMDE liaison. Some of the units are reorganizing and getting new unit identification codes (UICs). And that's causing a problem.

I can track their TMDE items using their old UICs and the TMDE app at: <https://idmng.armyerp.army.mil/>

But our local TMDE shop said they didn't know how to change to the new UICs. Do you know how to do that?

Mr. D.M.

Dear Sir,

Yes. Your TMDE shop needs to submit a Master Unit Identification Code (MUIC) request through the USATA home page:

<https://usata.redstone.army.mil/movrequest/>

Click New UIC Request and follow the directions.

Half-Mast

GIVE CROWS CLEARANCE



REMEMBER, WE CAN'T CLEAR ANYTHING LOWER THAN THIS.

Dear Editor,

Units with the M153 CROWS II installed on their vehicles need to emphasize to drivers the system makes a big difference in vehicle clearance.

CROWS adds at least three feet to the height of the vehicle. We've had several CROWS damaged because drivers forgot this.

If there's **any doubt** whether a CROWS will clear an overpass or tree limb, take a **different** route or use a ground guide.

SFC Reynaldo Reyes
Ft Hood, TX

Editor's note: Remind drivers to be aware of CROWS clearance before they leave the motor pool. CROWS parts can cost thousands to replace.

[Click here for a copy of these articles to save or email.](#)

M7 Spider Area Denial System...

RECHARGE WITH LITHIUM BATTERY SAFETY

YOU NEED SOME FRESH BATTERIES, LITTLE BUDDY.

JUST MAKE SURE YOU **DON'T** MIX 'EM UP!

If you don't follow basic safety rules for your M7 Spider area denial system's lithium batteries, equipment damage or even injuries could result!

Mixing old and new batteries can cause batteries to vent. This has happened in the past with the **LSH-20 lithium batteries**, NSN 6135-01-463-7077, in an M7's munition control unit (MCU) during testing of the M7E1 remote control unit.

Here's what you need to know when it comes to lithium battery safety:

- Replace all four batteries at the same time, using only fresh or fully-charged batteries.
- Always replace with batteries from the same contract number found on the battery label.

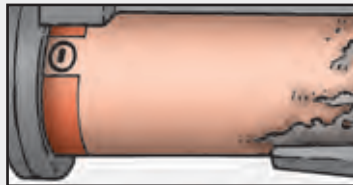
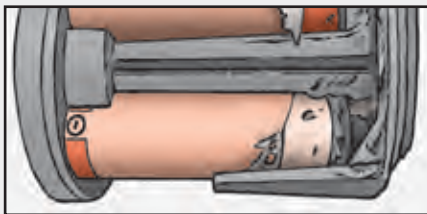

Mixing batteries with different contract numbers, manufacturers or dates can create safety and operational issues.

- Remember **not** all batteries are created equal, even if they look the same. **Never** mix batteries and **never** use a non-rechargeable and a rechargeable version of the batteries at the same time.

If you have an incident with a non-rechargeable battery, send an email to CECOM Directorate for Safety:

usarmy.APG.cecom.mbx.amsel-sf-sec-cecom-lcmc--ds@mail.mil

Then file a Product Quality Deficiency Report (PQDR) at:

<https://www.pdrep.csd.disa.mil/>

LOADING YOUR M2/M2A1
MACHINE GUN **INCORRECTLY** CAN
DO A NUMBER ON ITS BOLT.

THE BOLT'S TOP
SUFFERS DENTS,
GOUGES AND
EXCESSIVE WEAR.

Load Like This

Protect the bolt by loading like this:

1. Ensure the bolt is forward and the correct front and rear cartridges are installed.
2. Make sure the weapon is on S (Safe) with the cover closed.
3. Select **single shot** or **automatic fire**.

4. To select **single shot**, ensure the bolt latch release lock is in the unlocked position, turned to the right. The bolt latch release must be in the up position (not locked down).

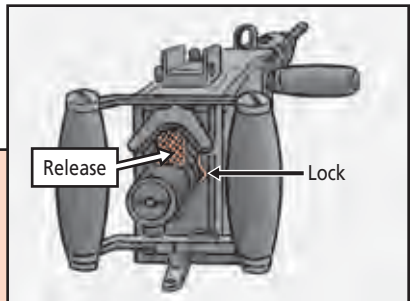

5. To select **automatic fire**, depress the bolt and lock by turning the bolt latch release lock to the left. Ensure the bolt latch release is held down completely with no movement.

6. Insert the double loop end of the ammo belt in the feedway until the first cartridge is held by the belt holding pawls.

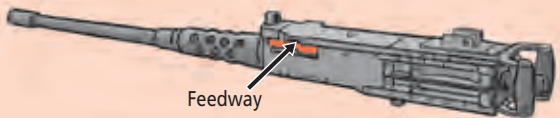

7. If firing **automatic** with the cover closed, pull the retracting slide handle all the way back until the bolt is completely to the rear. Release the handle. This half loads the machine gun.



8. Repeat Step 7. This completes loading in **automatic**.

9. If the M2A1 is set for **single** shot, the bolt will remain in the rear position, so move the slide handle forward before releasing the bolt with the bolt latch release.
10. With cover closed, pull the retracting slide handle back until the bolt is all the way to the rear. Push the retracting slide handle to the fully forward position. Depress the bolt latch release. This half loads the machine gun.
11. Repeat Step 10. This completes loading in the **single shot** setting.
12. Place the weapon on F (Fire).
13. Press the trigger to fire.

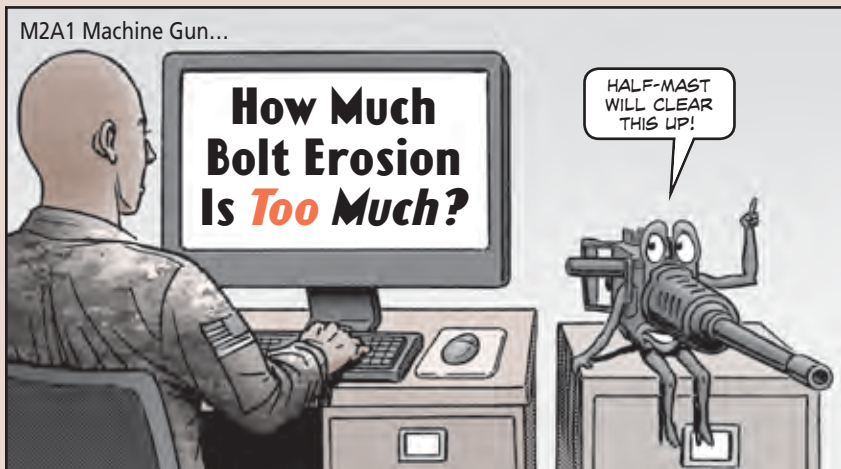

Dear Half-Mast,

WP 0018 00-3 in the M2A1 machine gun's TM 9-1005-347-23&P (Jul 11) says to inspect the bolt face for pits and/or eroded areas up to .062 inches long or wide, .031 inches deep in scattered or random patterns, or rings .031 inches deep and .062 inches wide.

I have bolts with eroded areas beyond .062 inches in length and width, but they don't meet the criteria for depth. Do they need to fail in length, width and depth to be considered NMC?

Mr. B.B.

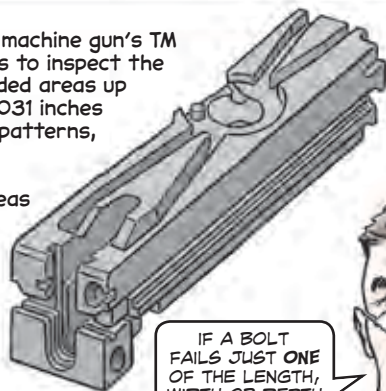

IF A BOLT FAILS JUST ONE OF THE LENGTH, WIDTH OR DEPTH CRITERIA, IT'S NMC!



M16-Series Rifle,
M4/M4A1 Carbine...

YOU JUST
WON'T FIT IN
THIS RACK!



WELL, THERE
ARE SEVERAL
WAYS TO FIX
THAT.

Fitting Rack Solution

Dear Half-Mast,

I've had trouble getting our M4 carbines to fit securely in the M12 racks. Of course, that's critical to security. Has the Army come up with any fixes for this?

SSG J.A.

YES, THERE **ARE**
SOLUTIONS...

...BUT WHICH
ONE YOU USE
DEPENDS ON
WHY YOUR M4S
WON'T FIT.



Older M12 racks need an adapter bar so that M4s can't be removed while the rack is locked.

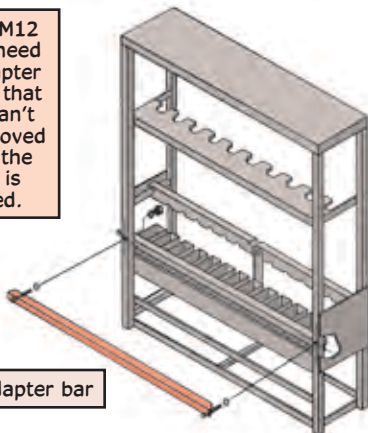

The instructions for fabricating and installing the adapter bar are in WP 0032 of TM 9-1005-319-23&P.



BUT IF THE PROBLEM IS CAUSED BY THE NEW FIRE CONTROL SELECTOR THAT WAS INSTALLED ON M4s AND M16 RIFLES SEVERAL YEARS AGO, THE FIX IS DIFFERENT.

THE SLOTS FOR OLDER M12 RACKS AREN'T WIDE ENOUGH TO ACCOMMODATE THE SELECTOR.

There are two approved methods to widen the slots.

Welding Pliers

Use welding pliers, NSN 5120-00-494-1895. Here's how:

1. Open the plier grips fully. Position the welding pliers 0.5 inches back from the face of the rack. Set the jaws to a size smaller than the sheet divider when the jaws are closed.



2. Squeeze the pliers in place on the rack until they lock and then remove them.

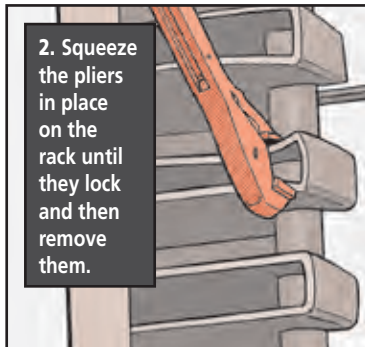

3. Test to see if the weapon fits in the rack slot.

4. If necessary, adjust the diameter of the pliers and go back to Step 2.



Mini Sledge Hammer

Use a 1 to 1½-in diameter steel bar and a 5-lb mini sledge hammer. Insert the bar in each rack slot and pound the bar with the hammer. That rounds out the flat portion of the slot, making it longer and narrower as well.

Test each slot to make sure it securely holds the weapon.

Any time you modify a weapons rack, you **must** have it certified by your local small arms LAR or security officer.

Fortunately, all M12 racks manufactured after Sep 2013 **don't** need these modifications.

Insert bar in slot and pound with sledge hammer

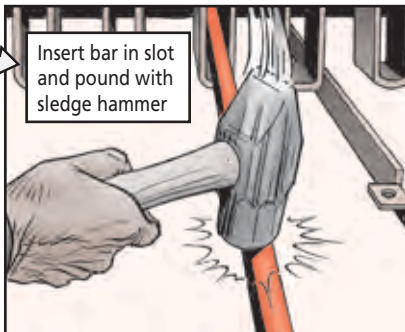

Store and Transport with Care



Dear Editor,

Here at Ft Leonard Wood, we're seeing too many cracked or broken M320A1 grenade launcher sight supports. The only fix is to order the entire leaf sight assembly kit, NSN 1005-01-564-2663, for \$55. And sometimes it can take a long time to get the kit.

But much of this damage is preventable if Soldiers and armorers just exercise a little care. The most critical thing to remember is **don't stack anything on top of an M320A1!**

In the arms room, armorers often store M320A1s on shelves and then pile other equipment on top, including other grenade launchers. Laying grenade launchers on shelves is fine. Just don't put anything on top of them.

Same thing goes for trips to the field. Don't pile other equipment on M320A1s and don't let them bounce around in the back of a truck. A good investment is a sturdy container for transport that protects launchers from equipment and feet. You can probably find containers around the unit that will work.

Charles Dutton
Ft Leonard Wood, MO

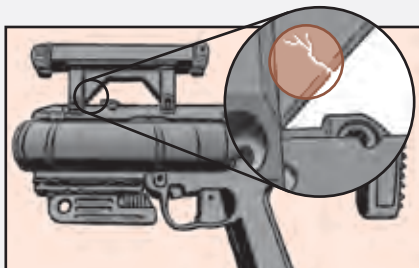

Piling stuff on M320A1 cracks sight support



Editor's note: *Common sense protection can keep M320A1s firing. Thanks for the tip, Charles. This just in! The launcher sight support can now be ordered with NSN 1005-01-682-2022.*

KEEP THOSE FACEFORMS & OUTSERT POUCHES!

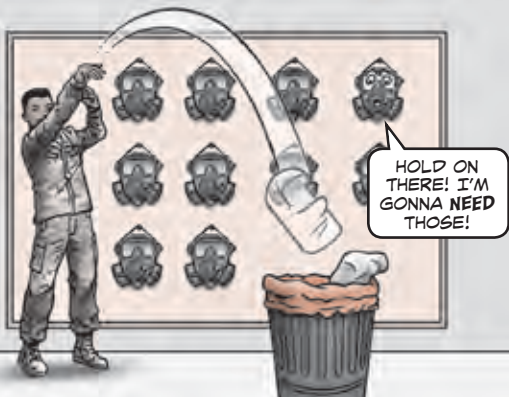

Dear Editor,

As a member of the Command Maintenance Training Team (COMET), I've noticed CBRN specialists and operators throwing away the faceforms and outsert pouches for the Joint Service General Purpose (JSGP) masks.

They don't realize that both the faceforms and outsert pouches **have a purpose** and aren't just packing material.

The FaceForm is needed if the JSGP masks are going to be stored for more than 30 days or for shipment. Otherwise, the mask can lose its shape and possibly its seal. If the seal goes, the facepiece must be replaced.

The outsert pouch is needed for much of the cleaning procedure detailed in WP 0017 00-2 in TM 3-4240-542-13&P (May 08). The pouch is used for both cleaning and drying.

David Whitmire
JBLM, WA

Hang on to faceform...



...and
outsert
pouch

Editor's note: *More good advice from you, David.*

The faceform should be installed inside the facepiece so the beard on the faceform matches the mask's beard. Pull all four straps over the faceform to keep it in place.

When faceforms aren't being used, they need to be stored in the CBRN room so they don't disappear.

Don't order new faceforms with the NSN in the TM. It's wrong. Instead, use NSN 4240-01-617-0948.

Match faceform beard with mask beard and secure with all 4 straps



POWER CABLE SPARKS PROBLEMS

HEY, WHEN YOU WORK ON MY INTERCOM SET LATER...

...DON'T FORGET TO REMOVE THE INPUT POWER CABLE FROM MY MT-6352, BEFORE REMOVING OR ATTACHING THE MCS POWER CABLE.

GOT IT AND I'M ON IT!

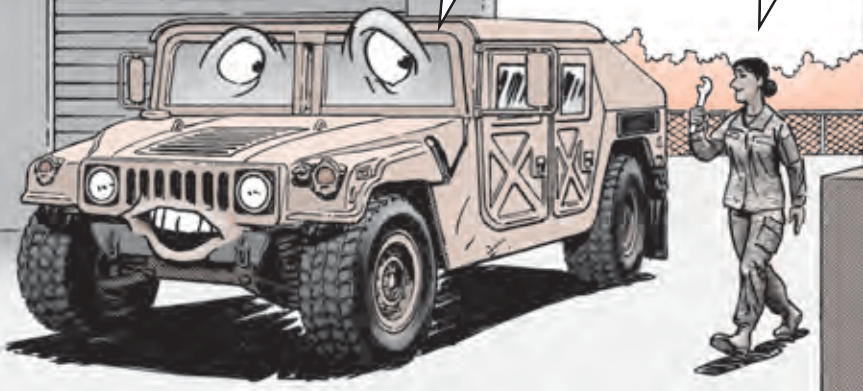

Although the AN/VIC-3, vehicle intercom system (VIS), has been in the field a long time, there's an **ongoing issue** with the power cable. If not fixed, it may cause **injury and equipment damage**.

The **problem** is the power cable can short against various items when not connected to the master control station (MCS) part of the VIS.

The MCS is powered from the MT-6352A mounting base, via the output connector on the far right.

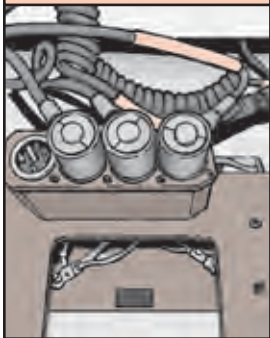

If power is connected to the mount, the cable has 24 VDC on its female connectors.



The two pins themselves protrude from the cable end.



If placed on a flat, conducting surface, this connector sparks and melts the female connectors, rendering the VIS **unusable**.

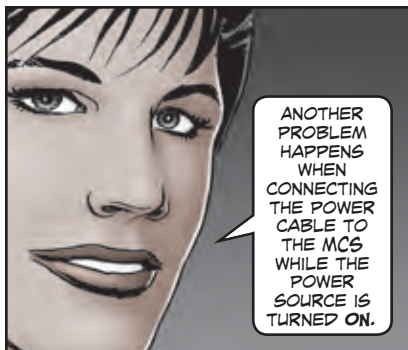

Protruding pins may spark when attempting to connect power cable while power is on

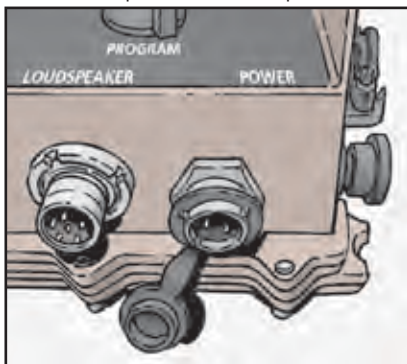
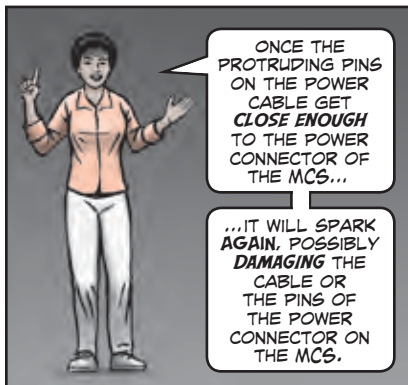

It's good practice to always leave the power connector to the MCS connected. However, if replacing a faulty MCS, the main power to the vehicle should be turned **off** prior to removing the MCS power cable.

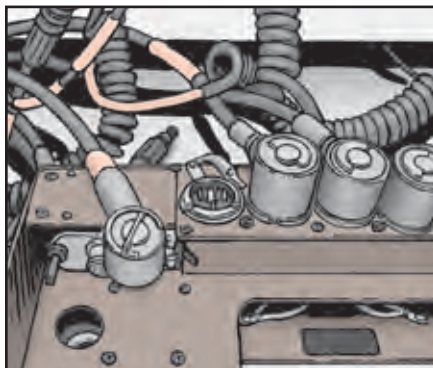

Remove input power cable from MT-6352 **before** removing or attaching MCS power cable

36KS, FALL OUT! YOU'RE URGENTLY NEEDED ON A MISSION.

FOLLOW ME AND SEE THE BEAUTIFUL POCONOS!

Power Play: Turn-in ECUs/FDECUs

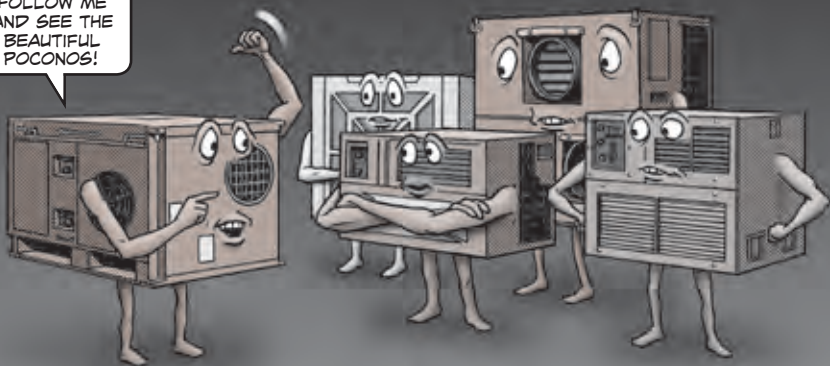

Units, heed this call!

36K Environmental Control Units (ECUs) and 66K Field Deployable Environmental Control Units (FDECUs) are *urgently* needed to fill *shortages*!

ROUTINE FIELDING REQUIREMENTS, DISASSEMBLY AND UNITS SENDING DEGRADED ASSETS DIRECTLY TO DLA DISPOSITION SERVICES HAVE RESULTED IN A **HUGE REDUCTION** IN INVENTORY.

THE VAST MAJORITY OF ASSETS ARE **UNSERVICEABLE** FIELD RETURNS THAT WERE EXPOSED TO THE ELEMENTS.



As a result, CECOM needs supply stock for 36K legacy assets, and requests turn-ins of unit excess on-hand equipment of NSNs 4120-01-219-8759 and 4120-01-467-2638 specifically. The 66K FDECU is needed for its chemical, nuclear, biological, radiological and explosives (CBRNE)-hardened capability.

The FDECU is also a mission-critical component of CBRNE Deployable Medical Systems or CP DEP MEDS, which is NMC without them.

More than 900 FDECUs are needed just to meet the current mission.

Until the FDECU replacement is fielded, NSN 4120-01-449-0459, LIN A26852, should be turned in to Tobyhanna Army Depot (TYAD).



These ECUs/FDECUs will be **removed** from the master divestiture list, and should be **turned in**:

Nomenclature/Description	NSN 4120-	LIN
Air Cond 66000 BTU, FDECU 66K	01-449-0459	A26852
Air Cond 3791, ECU 36K	01-219-8759	A24763
Air Cond 36000 BTUH, ECU 36K	01-467-2638	A24763

Ship these assets to TYAD at the following address:

TYAD: RIC: BY6
 PLANT: 7000 DODAAC: W25G1W
 XR W1BG UEF DIST DEPOT TOBYHANNA
 MYERS AND SECOND STREETS
 WAREHOUSE 2 BAY 1
 TOBYHANNA PA 18466-5059

Questions? Email Sydney Mapp at:
sydney.w.mapp3.civ@mail.mil

Night Vision Viewer TM Debuts

TM 11-5855-341-10 (Mar 19) is the new operator's manual for the AN/PSQ-40 night vision viewer, NSN 5855-01-649-9837.

TM distribution is restricted, so you'll need your CAC to log in to:

<https://idmng.armyerp.army.mil/>

Choose the "ETM/IETM" app and search for the TM.

New CDSS TM Hits Virtual Shelves

TM 11-7010-638-13&P (Apr 19) is the new operator and field maintenance manual, including repair parts and special tools list, for the AN/GYK-78B(V)3 cross domain server set (CDSS), NSN 7010-01-672-9088.

TM distribution is restricted, so you'll need to log in with your CAC to:

<https://idmng.armyerp.army.mil/>

Choose the "ETM/IETM" app and search for the TM.

IFS TM Includes RPSTL

The AN/TYS-94H (V)2 Intelligence Fusion Server (IFS), NSN 7010-01-664-0660, is covered in TM 11-7010-659-13&P (Oct 18).

TM distribution is restricted, so you'll need to log in with your CAC to:

<https://idmng.armyerp.army.mil/>

Choose the "ETM/IETM" app and search for the TM.

HOWDY, I'M THE NEW KID IN TOWN. MY BII COMES COMPLETE WITH CABLES!

YEAH, BUT ARE THEY THE RIGHT ONES?

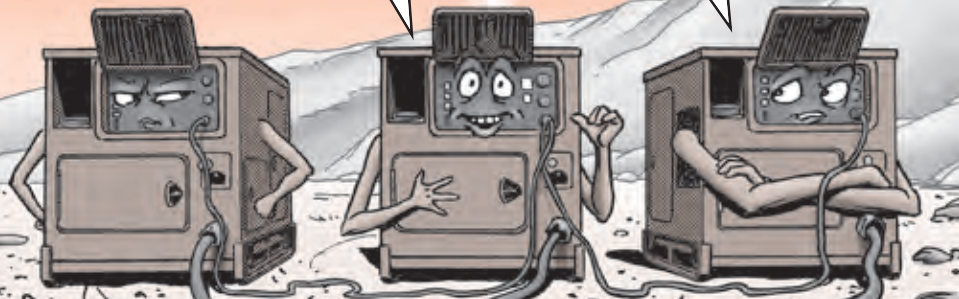

MY RIGHT ARM FOR THE RIGHT CABLE

Dear Half-Mast,

Our unit received an MEP-1030 5-kw tactical quiet generator (TQG) set, NSN 6115-01-561-7329 (LIN G42488). Included in the set was a cable, NSN 6150-01-586-0026 (PN 04-21228, CAGE 30554).

But in WP 0019-3/4 of TM 9-6115-749-10 (Feb 11), the Basic Issue Items (BII) Section lists a paralleling cable, NSN 6150-01-406-9533 (PN 88-22209), as the right cable for this generator.

Was the wrong cable sent to us?

Mr. G.S.

NO, SIR, YOU'VE GOT THE RIGHT CABLE.

WHAT'S **WRONG** IS THE CABLE LISTED IN TM 9-6115-749-10. THIS IS THE **OLDER** PARALLELING CABLE, AND THE TM HASN'T BEEN UPDATED YET TO REFLECT THE CABLE CHANGE.

FUNDING ISSUES AND PERSONNEL SHORTAGES HAVE LED TO DELAYS IN UPDATING SOME TMS, SO MAKE A NOTE OF THIS CABLE UPDATE TO KEEP THE **NEXT** SOLDIER IN THE KNOW.

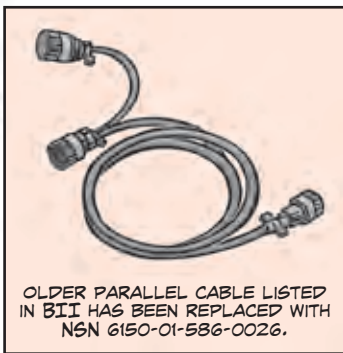

OLDER PARALLEL CABLE LISTED IN BII HAS BEEN REPLACED WITH NSN 6150-01-586-0026.

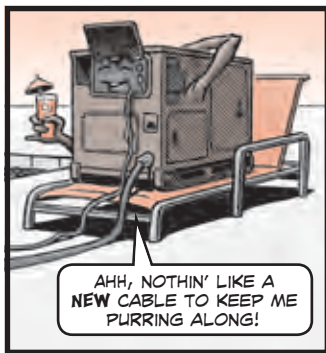

PRACTICE SAFE SAFETY



I WISH THAT LAST UNIT HAD LEFT THE COMBINATION. I DON'T KNOW HOW I'LL EVER GET YOU OPEN.

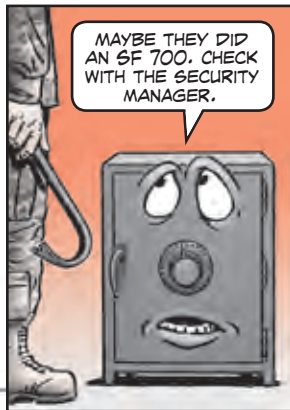

Dear Editor,

Every unit has some sort of safe for sensitive and classified material and most units have vaults for storing small arms. These safes and vaults have one critical thing in common: combination locks.

The problem comes when a unit transfers and fails to tell the incoming unit what the combinations are to these locks. It's a major hassle to get the safe or vault opened without the combination. A lockout can cost a unit thousands of dollars for a locksmith, depending on where the container is.

That's why units need to remember every device with a combination lock requires an SF 700, a government standard form used for tracking the combination of a security container or door.

SF 700 is prescribed by NARA/ISSO 32 CFR 3002 and by DoDM 5200.01. It's a three-part form consisting of an envelope with a tear-off tab and cover sheet.

The cover sheet provides space for information about the container, type of lock and the person to contact if the container is left open. It should be sealed in an opaque envelope marked "Security Container Information." The envelope should be taped on the inside door of the container or vault.

But, most importantly, the combination should be written down on the tab, torn off from the SF-700 envelope, sealed in the SF-700 envelope and given to the designated security officer to be stored in a safe at the same classification level. That way the combination is always available and no safes have to be forced open.

Normally, the Special Security Officer or Command Security Manager would hold the SF 700s, but it's up to the local command. The SF 700s should be stored according to the instructions that come with the SF 700.

Your security people should have copies of SF 700. If not, order them with NSN 7540-01-214-5372.

One other point: If a safe or vault door starts acting like it doesn't want to open, report it and get the door fixed. If you let it go until it won't open, you'll have some explaining to do to your commander.

Tony Gibson
Ft Stewart, GA

Editor's note: *I suspect many units aren't aware of the SF 700. Better safe than sorry.*

[Click here for a copy of this article to save or email.](#)

Taking Ownership of Tactical Fuel-Burning Heaters

SUMMERTIME

HELP! WE NEED TO BE MAINTAINED!



WHAT'S IN THERE?



AH, THAT'S A BUNCH OF HEATERS. WE KEEP 'EM IN THERE TIL WE GOTTA GET 'EM READY FOR THE WINTER.

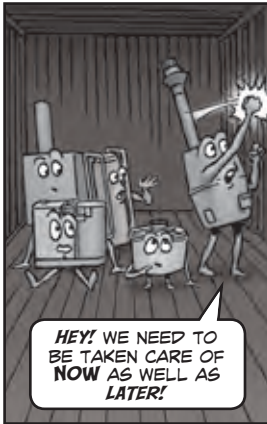

HEY! WE NEED TO BE TAKEN CARE OF NOW AS WELL AS LATER!

WE HEARD YA! WE'RE GOING TO REPAIR AND REPLACE YOUR PARTS WITH SOME COTS PARTS JONES FOUND.

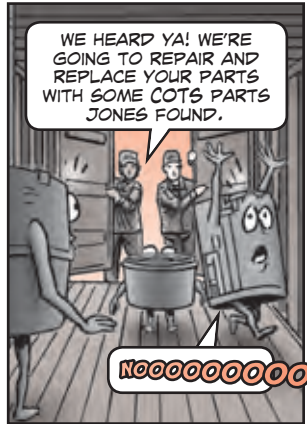

NOOOOOOOOO!

TODAY'S TOPIC IS HEATER MAINTENANCE... TAKE IT AWAY, SAMMY HARDEN!

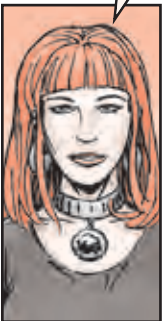

Dear Editor,

As a Power Generation/Environmental Systems LAR, I'm often asked to assist with systems maintained by the 1D, 91C and 91J MOs (ground support maintainers). Although most fuel-burning heaters are maintained by TACOM-LCMC, I'm familiar with them.

I've noticed very little emphasis is placed on heater maintenance until it's winter and units are getting ready for the field.

Heater maintenance is a **year-round effort**, and should be part of a unit's preventive maintenance checks and services (PMCS). Fuel gets contaminated, condensation builds up in fuel cells and causes rust, and rubber hoses crack and dry-rot while sitting in the motor pool or CONEX.

But there's also another issue that I've observed, and that's the amount of commercial-off-the-shelf (COTS) fuel-burning systems that are being purchased through HDT (Formerly DRASH) or other manufacturers. This leads to several problems, such as finding replacement parts or TMs. It also creates safety issues, like fire hazards and the possibility of carbon monoxide poisoning. Also, LARs can't make repairs on systems that haven't been properly tested and vetted by the Army.

[Click here for a copy of this article to save or email.](#)

There are systems that are manufactured by HDT and approved as systems of record (SORs). But just because an item has an NSN, doesn't mean it's an SOR.

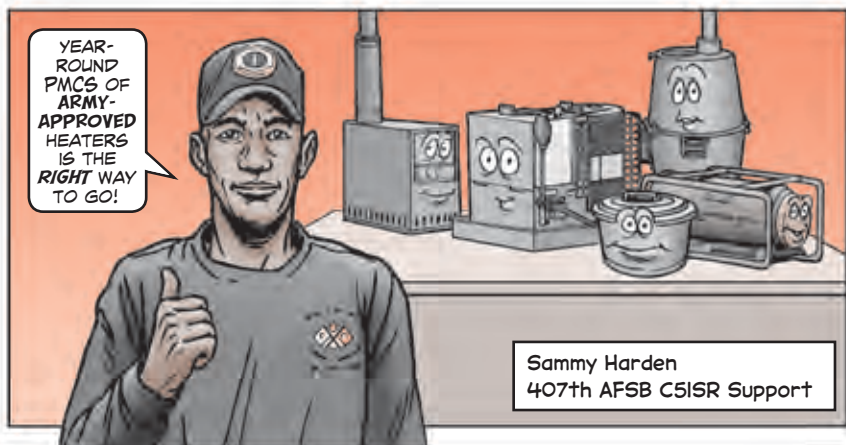

YOU'VE GOT US FIRED UP, TOO, MR. HARDEN!

As Mr. Harden points out, most COTS equipment *hasn't* gone through Army TM verifications or validations to make sure it meets military standards.

FINDING PARTS AND TMS IS *ALSO* TOUGHER. STICK WITH ARMY-APPROVED HEATERS AND PUT SOLDIER SAFETY FIRST.

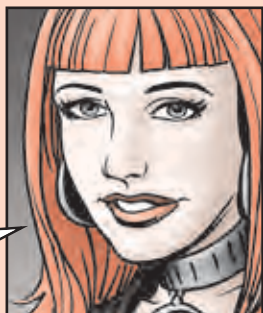

For more guidance and info on authorized heaters, see the PS Magazine article on Pages 46-51 of PS 758: <https://www.logsa.army.mil/web2/archive/PS2016/758/758-46-51.pdf>

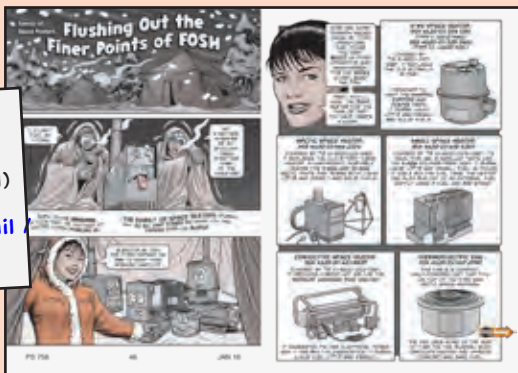

PS 803

SURE GLAD WE READ THAT HOW-TO 'BOLT REFUELING ON THE MOVE.

YOU AND ME BOTH!

PLANNING FOR PETROLEUM OPS

The *Petroleum Planning and Operations Smart Book* (Dec 18) gives instructions for planning and carrying out petroleum support operations. This in-depth guide is almost 200 pages and covers refueling equipment, petroleum planning and much more, with plenty of graphics and pics. Best of all, it's updated every year.

The smart book is behind the CAC firewall, so you'll need to go to the main US Army Petroleum Center (USAPC) public website at:

<https://usapc.army.mil>

Click on the To CAC-Enabled Website button and log in with your DOD email certificate to find and access the pub. Have questions or trouble finding the guide? Email:

usarmy.belvoir.usamc.mbx.usapc---operations-div@mail.mil



Guide covers petroleum operations from A to Z

To find smart book, press yellow button to access CAC-enabled website



How Do I RTD?



Dear Cloe,

Pages 56-57 of PS 777 (Aug 17) described how to turn in excess furniture to DLA Disposition Services. What's the process if your unit needs to **request** Furniture from DLA?

SPC H.L.

Dear Specialist,

To access DLA's reutilization, transfer and donation (RTD) program, you'll need to create an Account Management and Provisioning System (AMPS) account. Check out pages 55-60 of PS 801 (Aug 19) for instructions:

<https://www.logsa.army.mil/web2/archive/ps2019/801/801-55-60.pdf>

Or follow this link:

<https://www.dla.mil/DispositionServices/DDSR/PropertySearch/RTDAMPS/>

You'll also need to request the AMPS role in DLA Disposition Services Prod RTD Customer DDS-413.

Once you've established an AMPS account and received your AMPS role, you'll need to setup access to the RTD website. Here's how:

Go to the DLA Enterprise External Business Portal website:

<https://business.dla.mil/>

Click the Registered Users Login Here button.



If you're using a CAC, choose your email certificate.

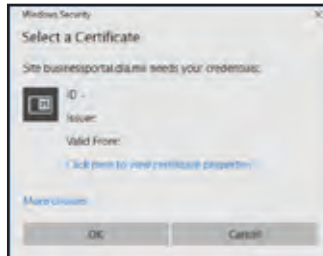

Otherwise, enter your user name and password.



Select the Disposition Services tab and...

DEFENSE LOGISTICS AGENCY
Enterprise Business System Portal

Welcome to EBS: SSO SAPGUT BusinessObjects CRM Disposition Services EDW FEDMALL Nanopistics

Disposition Services

Detailed Navigation

- Compliance
- ITD
- RTD

Click a link in the Detailed Navigation section to the left to launch the application in a new window.

...click the RTD link on the left side of the page.

DEFENSE LOGISTICS AGENCY
Disposition Services

Home | About Us | Public Affairs | Publications | FAQs | FOW

Reutilization / Transfer / Donation (RTD)
RTD Main

Request Role

On the RTD page, click Request Role and choose the correct application.

Since you're in the Army, you'd choose Department of Defense. Just below the application menu, you'll select your role. If you aren't an Account Supply Officer (ASO) or a Property Book Officer (PBO), choose DoD Screener. If you're not sure whether or not you're an ASO or PBO, contact your chain of command. Click Submit and an application form will open.

DEFENSE LOGISTICS AGENCY
Disposition Services

Home | About Us | Public Affairs | Publications | FAQs | FOW

Reutilization / Transfer / Donation (RTD)
RTD Pre-Register

Application: Department of Defense (DOD)

Role:

- DoD
- DoD ASO
- DoD Soldier
- RTD Vial Customer
- Small Arms Approver
- Small Arms Screener

Choose:

- Child Abuse Patrol (CAP)
- Computers for Learning (CFL)
- Department of Defense Contractor (DDOC)
- Education Services (DES)
- Education FEPO (FEPC)
- Firefighter (FF)
- Foreign Military Sales (FMS)
- Federal/State Soldier (FS)
- Humanitarian Assistance Program (HAP)
- Law Enforcement Support Office (LESO)
- Military Affiliate Radio System (MARS)
- Reserve Officer Training Corps (ROTC)
- Service Museum (SVMUS)
- Small Arms (SAS)

PS MORE

User Information

Title:

* First Name:

* Last Name:

* Organization Name:

* Work Address Line 1:

Work Address Line 2:

* Work Address City:

* Work Address State:

* Work Address Zip:

Country:

* Work Phone:

Work Ext:

Work Fax:

* Work Email:

Customer Type:

* DODAAC:

Opt out of all email?

Receive IBM notification email:

Receive property receipt email:

Systems 

Fill out the application form and make sure you use the correct requisitioning DODAAC. Click Submit.

Once your request for an RTD role is reviewed, you'll receive an email either approving or denying it. If approved, log back into the DLA External Business Portal and you'll see a DoD link. Now you're ready to search and request property.

Click the link to find out how:
<https://www.dla.mil/DispositionServices/DDSRS/PropertySearch/SearchForProperty/>

If your request is denied, you'll receive an explanation in RTD Web.



Turn To PSCC for HAZMAT Help

If you need to store or ship HAZMAT, turn to the Army Sustainment Command's Packaging, Storage and Containerization Center (PSCC) for advice. Get started by sending an email to: usarmy.tyad.usamc.mbx.pt@mail.mil

CCDC-DAC Helps with Bench Stock

Looking to get your bench stock under control? The Combat Capabilities Development Command-Data and Analysis Center (CCDC-DAC) is here to help. CCDC-DAC offers bench stock solutions tailored to your unit's equipment. Email CCDC-DAC to find out more: usarmy.apg.ccdc-dac.list.SSL-request@mail.mil

[Click here for a copy of these articles to save or email.](#)

Supply Management...

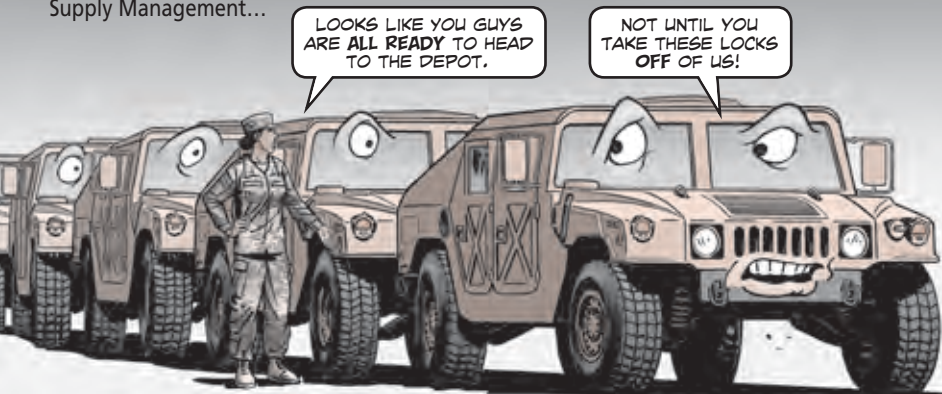

PRICY PADLOCK REPLACEMENTS

The Series 200 padlock is used to secure military vehicles and Basic Issue Items (BII) inside vehicle stowage boxes. And they've cost the Army more than \$18 million dollars!

It's not that the padlocks cost much individually or as a set; it's that they get turned in with vehicles shipped to depots for overhaul. To retain control of the padlocks, it's important to follow the key control guidance provided by:

- AR 190-11, *Physical Security of Arms, Ammunition, and Explosives* (Nov 2006).
- AR 190-51, *Security of Unclassified Army Property* (Sep 93).
- AR-735-5, *Policies and Procedures for Property Accountability* (Nov 2016).

Also, follow any unit standard operating procedures (SOPs) related to key control and don't let locks go on vehicles to the depot.

Containerization...

PSCC Offers Training Videos

The Army Sustainment Command's Packaging, Storage and Containerization Center (PSCC) is developing an instructional video series on the Care of Supplies in Storage (COSIS). The videos provide step-by-step procedures on key tasks such as care of long-life reusable containers, shelf-life inspections, and care of electrostatic discharge sensitive items.

They're designed to assist both technical and non-technical personnel who receive or store Army material.

The first video in the series is on the care of long life reusable containers and is available on the **ASC Training: PSCC Playlist** on YouTube:

https://www.youtube.com/playlist?list=PL9hNyopBeuXUKsPXkRixzqEdwvk8M_kkL

PSCC will add more training videos soon, including one on shelf-life inspections, so make sure to bookmark their channel and check it regularly for new content.

Connie's POST PS SCRIPTS

I WOULDN'T TRICK YOU! YOU CAN TREAT YOUR UNIT TO IMPROVED READINESS WITH THESE BRIEFS.

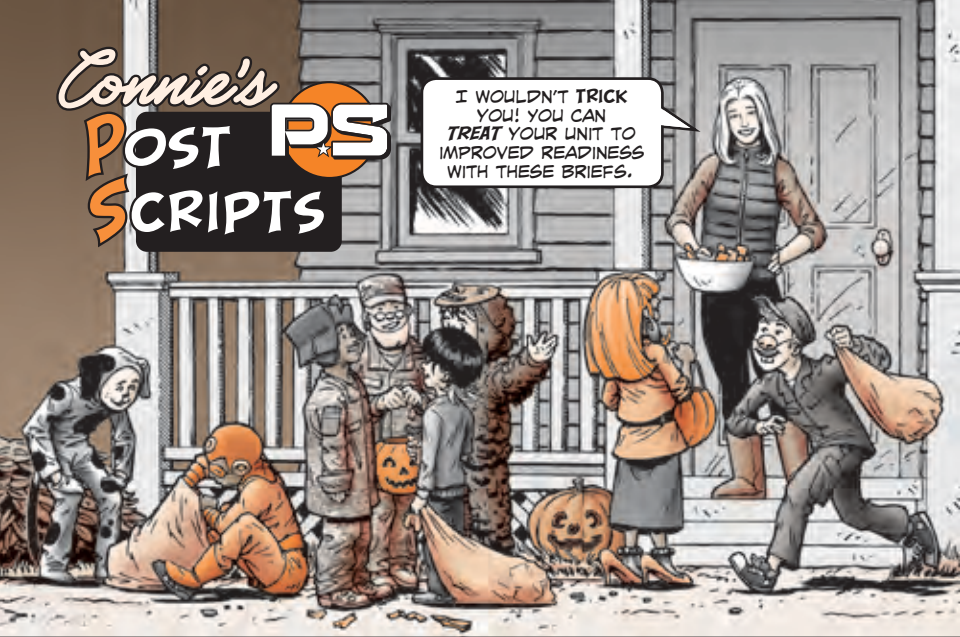

Up-Armored HMMWV Ball Joint

Order a replacement for the up-armored HMMWV's front or rear upper ball joints with NSN 2530-01-554-8288. That's a new NSN, which replaces NSN 2815-01-601-6441, shown as Item 8 in Figs 163 and 147 of TM 9-2320-387-13&P (IETM EM 0323, Mar 14). But beware, the TM hasn't been updated yet!

M149A2 Trailer Master Cylinder

Get a new master cylinder for your M149A2 trailer with NSN 2530-01-339-8620. It replaces NSN 2530-00-204-4800, which is shown as Item 4 in Fig 7 of TM 9-2330-267-13&P (Dec 15). That NSN is a terminal item.

FMTV LTAS Transmission Control Valve Module Replacement Work Package

The FMTV LTAS transmission control valve module work package is being added back to TM 9-2320-333-23&P (IETM EM 0372, Nov 18) after it was removed during a recent TM update. This allows units to replace a control valve module instead of sending it to sustainment level maintenance.

Until the TM is updated, you'll have to ask your local LAR to access the work package and download it for you at Logistics Assistance Directorate CS&CSS #722464:

<https://gfs.tacom.army.mil/hd/default.cfm?p=td&rid=722464>

Or access it with your CAC at the PS Magazine milSuite site:

<https://www.milsuite.mil/book/docs/DOC-635604>

M3, M3A1 CROP Strap Assembly NSN

Webbing strap assemblies, NSN 5340-01-504-2426, for the M3 and M3A1 CROP flat racks have been replaced with NSN 5340-01-663-1029. The only difference between the two is color. The new strap is black instead of green. Make a note until TM 9-3990-260-14&P (Jul 01, w/Ch 1, Nov 06) is updated with the new NSN.

ATLAS Forklift Hydraulic Hose NSN

The part number for ATLAS hoist boom cylinder hydraulic line, listed as Item 3 in Fig 192 of TM 10-3930-673-24P (Jun 12), has two transposed numbers which resulted in an incorrect NSN. To order the hose, use NSN 4720-01-439-5070 (PN 2714382). The current parts info (NSN 4720-01-439-5061, PN 2713482) brings the priority valve hydraulic hose shown as Item 1 in Fig 183.

ATLAS II Forklift Floodlight NSN

Need a new floodlight for your ATLAS II forklift? Get it with NSN 6220-01-659-2472. It replaces NSN 6220-01-437-5616, which is shown as Item 16 in Fig 61 and Item 2 in Fig 62 of TM 10-3930-677-23&P (IETM EM 0359, Aug 16). That NSN is a terminal item.

Pallet Jack NSN

Get a new 5,500-lb pallet jack with NSN 3920-01-463-8450. Make sure you get your CO's approval before ordering.

BACKHOE LOADER SUPPORT

When you need repair parts, troubleshooting help or maintenance services for your backhoe loader (BHL), the first stop is TM 5-2420-231-24P (Jun 13). If you need help beyond the TM, remember to use your TACOM Logistics Assistance Representative (LAR) or send an email to:

usarmy.detroit.tacom.mbx.ilsc-excavators@mail.mil

FUEL TANKER CLEANING INSTRUCTIONS

Cleaning instructions for fuel tankers, which used to be in TB 43-0212, have been consolidated into ATP 4-43 (Aug 15), *Petroleum Supply Operations*. Find it at the Army Publishing Directorate:

<https://armypubs.army.mil/ProductMaps/PubForm/ATP.aspx>

M1082, M1095 Trailer Tire and Wheel Assemblies

The M1082 and M1095 trailer tire and wheel assembly NSNs listed on page 15 of PS 742 (Sep 16) have changed. Units should order tire and wheel assembly NSN 2530-01-571-5857. If you just need the tire, order NSN 2610-01-658-1299, which is a new NSN that combines the Goodyear MV/T (NSN 2610-01-564-6172) and Michelin (NSN 2610-01-572-6017) tires. The tire size is 395/85R20 for both.

Would You Stake Your Life ^{right now} on
the Condition of Your Equipment?

NOTHING'S SCARIER THAN BAD PMCS!



[Click here for a copy of this article to save or email.](#)