

Issue 802

PS

★
September
2019

THE PREVENTIVE MAINTENANCE MONTHLY

TB 43-PS-802

Approved for
Public Release;
Distribution is
Unlimited

Without proper operator training, driving the PLS in mud, snow, or other austere conditions can *wreak havoc* on the transfer case.



SEE PAGES
11-13 TO LEARN
MORE!



**THE
PREVENTIVE
MAINTENANCE
MONTHLY**

ISSUE 802 SEPTEMBER 2019



COMBAT VEHICLES 3

- M1-Series Tank Parking Brake PMCS 3
- M2/M3-Series Bradley M242 14-Pin Connector 4-5
- M88A2 Fire Prevention Tips 6-7
- M113A3 FOV Overheating Prevention 8-10



TACTICAL VEHICLES 11

- M1075/A1 PLS Transfer, Transmission Shifting 11-13
- FMTV Wheel Bearings Repack Interval 14-15
- M1151A1 HMMWV Gunner's Sling NSN 15
- MRAP Luminous Tape Placement 16



AVIATION 17

- MEDEVAC External Rescue Hoist Washer Change 17
- MEDEVAC Internal Rescue Hoist Lanyard Check 18-19
- MEDEVAC Hoist Briefings 19
- AGSE Composite Repair Kits 20
- UH-60M Searchlight Replacement 21
- UH-60A/L/M, H-60 Series EBAPS Kit PN Change 22
- Shadow UAV Maintenance Tips 23-26

**Crushing the ETM/IETM
MSD Conundrum**

27-34



MISSILES 35

- HELLFIRE Missile System PM Tips 35-37



SMALL ARMS 38

- M68 Reflex Sight PM Tips 38-39
- M249 Machine Gun, No Barrel Collar Movement 39
- M249 Machine Gun Feed Box Support Kit Update 40
- CCMCK Caution 41
- Stuck Parts, No Acetylene Torch Allowed 42
- JSGPM Carrier Security 42



TOOLS 43

- TMDE Calibration App 43-44



CONSTRUCTION 45

- M9 ACE Hatch Hinge Lubing 45
- HYEX Swing Bearing Ring Gear Lube 46
- 120M Road Grader Cab Safety 47



COMMUNICATIONS 48

- AN/VRC-104(V)5 Radio Installation Kit 48
- 5-kW TQG Muffler Gasket NSN 49
- ICIDS-V TM Released 49



SOLDIER SUPPORT 50

- Gas Cylinder Turn-in Help 50-51
- Fuel and Water Can Facts 52-53
- Medical Repair Parts through GCCS-Army 53-54



LOGISTICS MANAGEMENT 55

- LLRC Inspections 55-56
- UIC Transfer Instructions 57-58
- GCCS-Army Warehouse Activity Monitor 58-59

Connie's Post Scripts 60-61

TB 43-PS-802, *The Preventive Maintenance Monthly*, is an official publication of the Department of the Army, providing information for all Soldiers assigned to combat and combat support units and all Soldiers with unit maintenance and supply duties. All information published has been reviewed and approved by the equipment responsible for the equipment, publication or policy discussed. Application of the information is optional with the user. Masculine pronouns may refer to both genders. The use of product or company names does not constitute endorsement of those products, services or companies by the U.S. Army. The use of non-DoD hyperlinks, along with their content, does not constitute endorsement by DoD or DA. Neither DoD nor DA exercises any editorial control over, and cannot vouch for, content on non-DoD websites.

PS, *The Preventive Maintenance Monthly* (ISSN 0475-2953)
is published monthly by the Department of the Army, Redstone Arsenal, AL 35898.

You are invited to send PS your ideas for improving maintenance procedures, questions on maintenance and supply problems and questions or comments on material published in PS.

Just write to:

**MSG Half-Mast
PS, the Preventive Maintenance Monthly
USAMC ARMY SUSTAINMENT COMMAND
BLDG 3307
Redstone Arsenal, AL 35898**

Or email:
usarmy.redstone.asc.mbx.psmag@mail.mil

Internet address:
https://www.aschq.army.mil/home/psmag.aspx

By Order of the Secretary of the Army:

JAMES C. MCCONVILLE
General, United States Army
Chief of Staff

Official:

Kathleen S. Miller
KATHLEEN S. MILLER
Administrative Assistant
to the Secretary of the Army
1916956

DISTRIBUTION:
Distributed in electronic media only(EMO)

Back to Basics Readiness



It's time to reflect on past accomplishments and failures. The goal is to implement new plans that will maintain past successes and improve weak areas. For logisticians, this means reflecting on lessons learned from past missions and projects to improve processes needed to maintain readiness and predict future requirements.

I'd like to reflect on the days of old when TA-50 layouts, room inspections, field recovery, equipment maintenance, inventories and weapons cleaning were commonplace in a Soldier's daily activities.

As a young Soldier, I struggled to understand why we had to do these things over and over again. When returning from a long field exercise, visions of a hot shower and the bed quickly overshadowed the diligence needed to complete recovery activities.

Later, I found out quickly, and sometimes painfully, that those basic logistical checks and balances served as the foundation of readiness.

Something as simple as not recovering the heater for the tent and ordering required maintenance parts created a "cold" hard lesson during the next field problem.

During an FTX, a leader who overlooked the TA-50 inventory found that a Soldier had just a blanket because his sleeping bag fell off the truck during the previous field exercise.





A deployed Soldier had a flat tire in the middle of the desert and realized that the BII was short the jack and wrench.

These are but two examples of **readiness challenges** that could have been **prevented** by following the basic requirements outlined in command supply and maintenance doctrine and policies. Supply and maintenance discipline programs serve as the bedrock of combat readiness.

The Army provides all units with equipment and materiel needed to accomplish missions. Our mission as logisticians and sustainers is to ensure that we keep these resources in a mission-ready state. Let's get back to the basics of readiness.

Through command emphasis and activities such as recovery, inventory, maintenance and requisitioning replacement items, we lay a solid foundation for readiness. As logisticians and leaders, we play a critical role in ensuring the world's greatest fighting force is trained, manned, and equipped.

As the Chief of Staff of the Army has pointed out, *"Readiness is our number one, there is no other number one."* With this in mind, let's get back to the basics of supply and maintenance discipline to improve readiness and ensure the Army is ready to fight and win the Nation's wars.

CW5 Cheryl M. Bartly
DCS, G-4

This article originally appeared in the January 2019 issue of *Property Accountability Newsletter*.

M1-Series
Tanks...

HEY! WHERE
D'YA THINK YOU'RE
GOING?

NOT MY
FAULT!

YOU NEVER
DID PM ON MY
PARKING BRAAAAAAKE!

Parking Brake Part of PMCS

Dear Editor,

One PMCS check that tends to get overlooked by M1-series tank crewmen is making sure the parking brake works. It's a simple check but an important one because you don't want a tank moving when it shouldn't!

Before doing this check, make sure to warm up the engine for at least two minutes. If you don't, the engine and transmission could be damaged.

Just like the -10 TM says, once the engine is warmed up, move the shift control to D and run the engine just above idle speed. That's 1,000 to 1,100 rpms. The tank shouldn't move. If it does, tell your mechanic right away.

Check parking brake by
warming engine then...



...move
shift
control to
D and idle
engine at
1,000 to
1,100 rpms

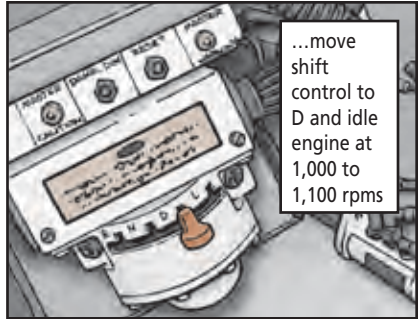

Also, if your tank's rpm gauge isn't working, you can still do the check by moving the shift control to R with the engine at normal (850 to 950 rpms).

SSG Mark Diaz
Ft Hood, TX

Editor's note: *Good info to know, Staff Sergeant Diaz!*

FOOD FOR M242 FEEDER THOUGHT

EVERY BRADLEY UNIT KNOWS THE M242 GUN IS A POWERFUL WEAPON...

...BUT THE 14-PIN CONNECTOR **MUST** BE TREATED WITH CARE OR THE GUN BECOMES NMC.



Just one moment of carelessness or rough handling can knock out that connector. And it happens **time and time again.**

Current figures show M242 motor drive replacements for broken connectors average 60 per month at an annual cost of **\$4 million!**

Just remembering a few tips can **wipe out** that cost.



WHEN YOU INSTALL THE FEEDER, MAKE SURE IT'S **PROPERLY ALIGNED** ON THE RECEIVER **BEFORE** YOU PUSH UP THE LOWER STRAIGHT DRIVE SHAFT.

If feeder is correctly aligned on receiver, drive shaft should lock in place easily

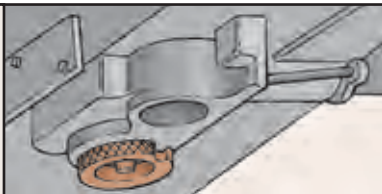

If the shaft doesn't want to go up, the feeder isn't aligned right. Reposition the feeder and try again. If the shaft won't go up even after you reposition the feeder, **STOP.**

Get your mechanic to check out the problem.

ONCE THE DRIVE SHAFT HANDLE IS LOCKED IN PLACE, THE FEEDER HANDLE **SHOULD** LOCK EASILY IN THE DOWN POSITION.

Once drive shaft is locked, push down on feeder handle to lock in feeder



IF IT DOESN'T, **DON'T FORCE IT.**

If you *do* force it, there goes the 14-pin connector!

Once again, call in your mechanic.

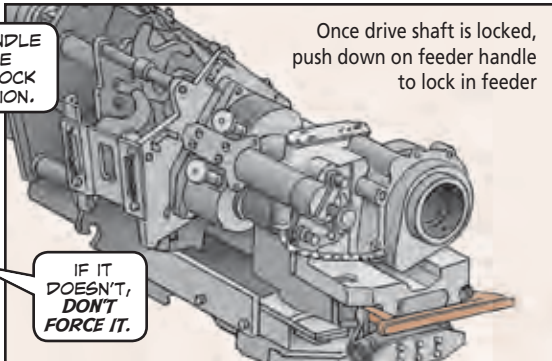

Part of the problem is that the M242's TM 9-1005-200-23&P gives a *different* feeder installation procedure than the Bradley's -10 TMs. The -23&P's is the **correct** procedure. But, unfortunately, Bradley crews usually *don't* see the M242 TM.

The **key difference** in the TMs is that the M242 TM correctly says to lock the drive shaft in place before pushing down the feeder handle to lock it in place. That ensures the feeder is correctly aligned so the 14-pin connector *doesn't* get damaged.

The Bradley TMs, on the other hand, have gunners lowering the feeder handle before locking the drive shaft in place. This **negates** the value of using the drive shaft as an alignment check.

The **easiest** solution is to print out the correct procedure from the M242 TM and give a copy to every Bradley crew in the unit.

First, go to <https://idmng.armyerp.army.mil/>

Next click on the ETM app to download TM 9-1005-200-23&P. The feeder installation procedure begins in WP 0026 00-9.

It's equally important to remember when the feeder is removed, the feeder handle **must** be put in the **down** position **before** placing the feeder on the floor.

The feeder handle serves as a stand for the feeder, much like a kickstand on a bike, and protects the 14-pin connector.

But crews need to remember the feeder handle **must** be put back in the **up** position **before** trying to align the feeder with the receiver.

It **can't** be done if the handle is down.

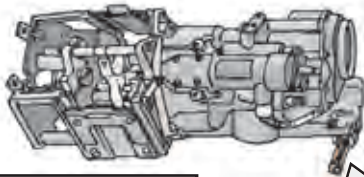

Before setting feeder on ground, put feeder handle in down position to protect 14-pin connector

But put handle up before trying to put feeder on receiver

Soldiers come and go in Bradley units. That's why the correct procedures for installing and removing the feeder need to be **constantly taught** and why copies of the M242 TM procedure are a **must**. It takes so little time to go over the procedures, but will **save** so much time and money in 14-pin connector repairs.

PREVENT FIRES WITH PREVENTIVE MAINTENANCE

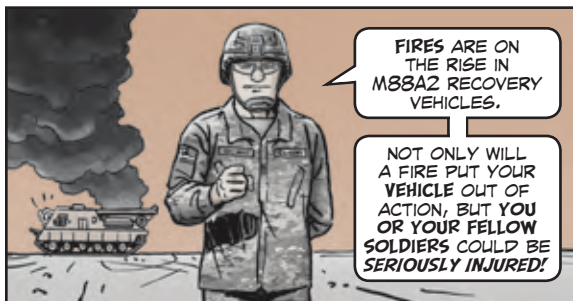
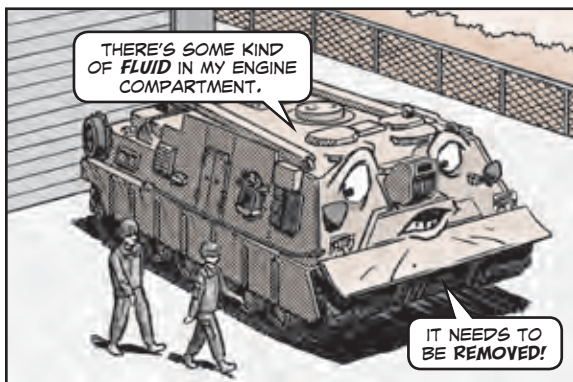

Oil and fuel pooling in the bottom of the crew, hull and engine compartments is a big concern because it can make fires much *more difficult* to extinguish.

Always clear fluid and debris from the vehicle before operations.

Here's how:

Crew Compartment

Check for water, fluids and debris that can collect on crew compartment floor plates. Remove any debris and then pull the drain lever next to the driver's seat in the crew compartment. Allow any fluid to drain. If you see oil or fuel in the drained fluid, check for fuel leaks and make sure they're repaired before operating the vehicle.

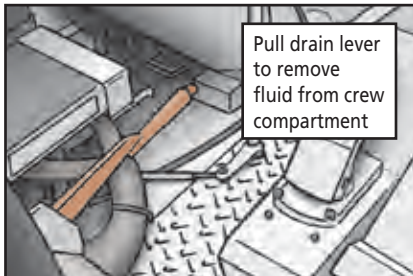
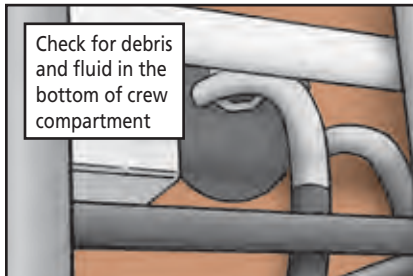

Hull Compartment

Lift the floor access panel behind the driver's seat and check for fluid in the hull compartment. If you see fluid, clear away any debris, position a drip pan, and then open the front drain valve.

Do not operate the vehicle without the drain valve or access plates installed. That can allow debris to get inside the engine compartment. It can also affect the engine cooling system and cause the engine to overheat.

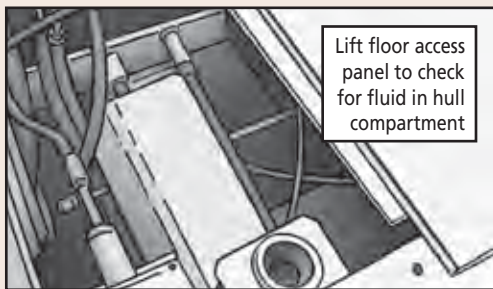

Engine Compartment

Remove the front engine deck grille doors to check for fluid in the engine compartment. If fluid is present, clear any debris, position a drip pan, and remove the rear drain plug.

Then open the driver's and mechanic's engine exhaust grille doors, as well as the transmission access doors. Remove any fluid or debris through the engine compartment bottom access panels. Also, be sure to check for fuel or oil on the exhaust grilles.

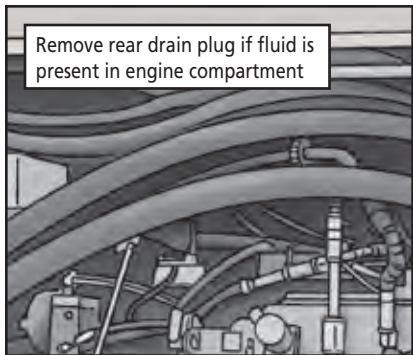

M113A3 FOV...

STAY
COOL
WHEN
HEAT
IS ON!

WHAT'RE
YOU DOIN'
HERE?!

JUST TRYING
TO KEEP COOL
IN THIS HEAT!

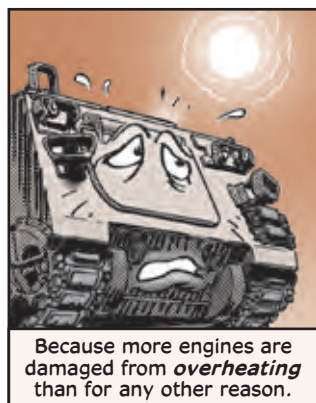

Coolant Levels

If the coolant is low, the engine overheats and is ruined. So remove the radiator cap and check the coolant level daily before operations. If the coolant is hot, check that the coolant reaches **HOT FILL LEVEL** in the filler neck. If coolant is cold, check that coolant reaches **COLD FILL LEVEL** in the filler neck. Add coolant as needed. If water was added, ask your mechanic to check the antifreeze protection level. Careful, hot coolant can burn you! Only use your hand to remove the cap if it's cool to the touch.

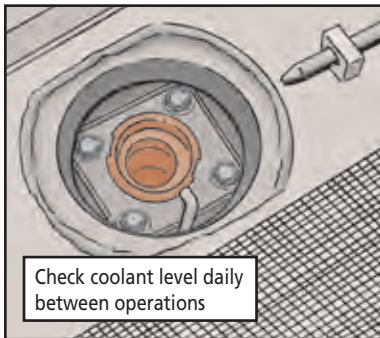

Engine Warmup

Your engine will last longer if you always warm it up before you head out. You need to give the oil time to circulate before moving your carrier. Check that the **ENGINE OIL LOW PRESS** warning light goes off within 10 seconds after engine start. Check that the **BATT GEN** indicator points to the green zone.

Run the engine at 1,000-1,200 rpm for three to five minutes. Then reduce the engine to idle speed (600-700 rpm).



THAT LETS THE COOLANT AND ENGINE OIL WARM UP.

JUST DON'T LET THE ENGINE IDLE FOR EXCESSIVE PERIODS OF TIME.

Engine Shutdown

Stopping the engine without a cooling down period can damage the engine. Don't stop the engine before the coolant temperature drops to 185°F or lower. Run the engine at 1,000-1,200 rpm for three to five minutes. Then return the engine to normal idle at 600-700 rpm. Pull the fuel cutoff control all the way out to stop the engine and set the **MASTER SWITCH** to OFF.

Air Cleaner

Your engine will lose power and overheat if the air cleaner element is choked with dirt. Check the air cleaner indicator often. If at any time only red shows in the window, tell your mechanic.

Belts

Check generator, coolant pump, and coolant fan drive belts for looseness, wear and damage. Replace any drive belt that's missing, broken, has cracks on the belt fiber, has more than one crack ($\frac{1}{8}$ inch in depth or 50 percent of belt thickness) or has frays more than two inches long.

Check the idler adjuster for proper adjustment between the operating range marks. If the idler is not in operating range and the coolant fan drive belt has more than $\frac{1}{2}$ inch deflection between pulleys, tell your mechanic.

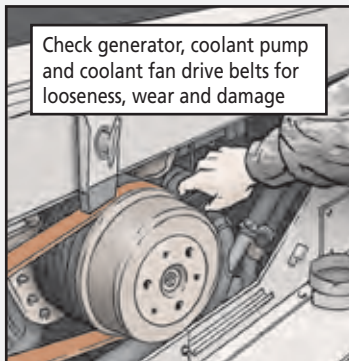

Radiator Fins

The radiator can't do a good job of conducting heat if its fins are clogged with dirt, oil, leaves, grass or twigs. Anything that restricts airflow through the radiator keeps the coolant hot and overheats the engine. Your mechanic can clean the fins with low-pressure water.

Keep packs, water cans, tents, camouflage screening, poles and other equipment off the air intake and air exhaust grilles.

Make sure both are clean and free of dirt, twigs, leaves and other debris. If you use protective covers over the grilles, make sure they're rolled up and strapped in place before operating your vehicle.

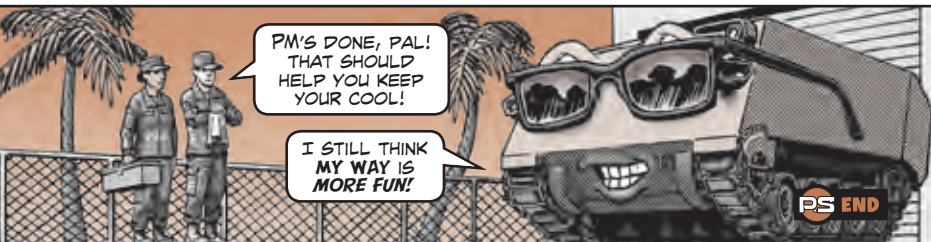
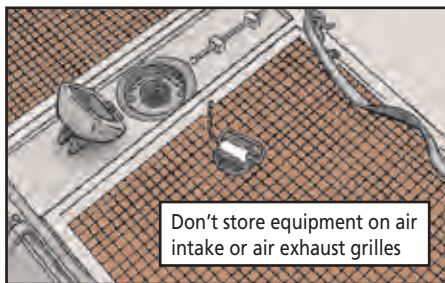

TRANSFER CASE TRAGEDY

PREVENTING MAINTENANCE PROBLEMS IS WHAT *PS MAGAZINE* IS ALL ABOUT.

THE *BEST* PREVENTION STARTS WITH TRAINING.



CONSIDER THE M1075 PLS, FOR EXAMPLE. THIS WORKHORSE IS BUILT FOR HEAVY JOBS IN AUSTERE ENVIRONMENTS.

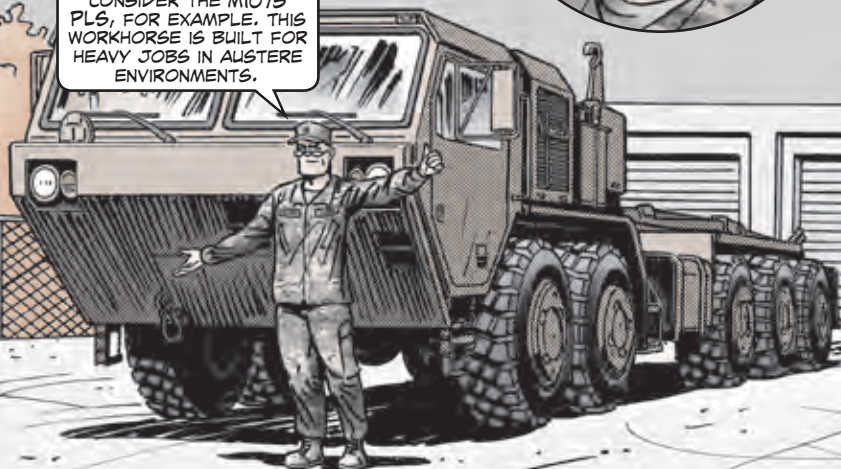

For the PLS to perform, however, operators must be properly trained, and *re-trained*, on driving and shifting in *adverse conditions*, as detailed in the TM.

Base model PLS trucks follow adverse driving conditions covered in WP 0067 of TM 9-2320-364-10-1 (Sept 16).

For the PLS A1: refer to TM 9-2320-319-10-1 (Oct 18).

Two work packages are especially important:

- **WP 0029**,
Operating Transmission and Transfer Case
- **WP 0031**,
On Road Driving Procedures

Slippery Conditions

Driving the M1075 PLS can be **challenging** in wet, slippery, muddy or snowy conditions where operators must frequently shift the transfer from high to low and vice-versa to keep the truck moving.

Muddy conditions require frequent high to low transfer shifts



In some cases, operators must switch the transmission from drive to neutral **a few times** while shifting the transfer in order to achieve the desired range.

Transmission and transfer case operation for the M1075 PLS is detailed in WP 0034, and specific transmission ranges are listed in WP 0010, Table 1 of TM 9-2320-364-10-1 (Sept 16).

If a low range is required, like in muddy conditions where the wheels spin or for maneuvering down steep inclines, the drivetrain and the transfer can be seriously damaged if the operator doesn't properly downshift the transmission range selector into low range.

USE LOW RANGE FOR STEEP DOWNHILL DRIVING.

Normal Conditions

THE OPPOSITE IS ALSO TRUE IN HIGH RANGE, WHICH IS FOR DRIVING UNDER NORMAL ROAD CONDITIONS AT INCREASED SPEEDS.

If operators fail to shift out of low into high range and drive the truck faster while still locked in low range, the drivetrain and transfer will **definitely** be damaged.

Don't drive fast while locked in low range

Lockup switch

Shift lever

Normal Conditions, continued

It's also a **huge error** to engage the transfer case:

- while the truck is moving.
- when the transmission is in gear.
- when the wheels are slipping.
- when turning a corner.

Any one of these scenarios will *seriously damage* the transmission because it engages the transfer case while the wheels are still spinning.

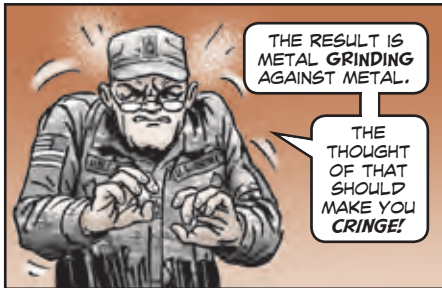

Signs of Damage

Clear signs the truck has been operated at high speed while locked in low range or shifted while the transmission is in gear include:

- grinding noises.
- locked gears.
- metal shavings or chunks in the transfer case, usually discovered when the case is drained or flushed.

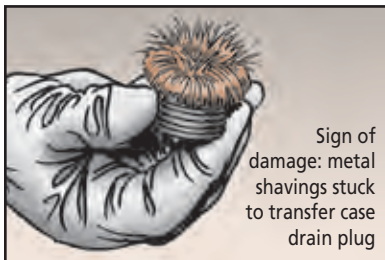

The Fix

TO KEEP OPERATORS PROPERLY TRAINED, UNITS SHOULD MAKE SURE THEIR DRIVER SUSTAINMENT TRAINING PROGRAM FOLLOWS THE REQUIREMENTS OF AR 600-55, THE ARMY DRIVER AND OPERATOR STANDARDIZATION PROGRAM (MAY 17), AVAILABLE AT:

<https://armypubs.army.mil/ProductMaps/PubForm/AR.aspx>



Units should also emphasize proper driving techniques during convoy pre-briefs.

Strict compliance with TM operations and procedures should be the norm.



THIS IS A GOOD PROJECT FOR THE UNIT'S MASTER DRIVER TO LEAD. FIND MORE INFORMATION AT:

<https://safety.army.mil/ON-DUTY/Drivers-Training-Toolbox>



FMTV...

TIME TO



REPACK!

IT'S NO WONDER YOU'RE CONFUSED. THE TMS ARE UNDER REVISION TO CLARIFY THIS ISSUE.

Dear Half-Mast,

I work at a TACOM FMX where we maintain a fleet of FMTV-series vehicles, including LMTVs and MTVs.

The TM for these vehicles says to check the wheel bearings every 12,000 miles or once a year, and to repack the bearings every 12,000 miles or when an inspection reveals an oil leak or when the wheel assembly is taken apart for other maintenance.

Our practice is to remove the wheel hubs and bearings on these FMTVs every year, regardless of the mileage. We clean, inspect and repack the wheel bearings, even on vehicles that have not met the 12,000 mile mark.

Are we doing the right thing by removing these bearings every year, or are we wasting man-hours, repair parts and training time?

Mr. W.H.J.

Dear Sir,

This is a tricky question because the TM for the -A1 models says to repack every 12,000 miles. But the TM for the -A1P2 models says to repack every 12,000 miles OR annually, whichever comes first.

TACOM tells me they're in the process of revising the TMs to be consistent between both models. The -A1P2 model TM will be revised to say: "Repack the bearings every 12,000 miles or when an inspection reveals an oil leak or when the wheel assembly is taken apart for other maintenance."

Half-Mast

Repack wheel bearings every 12,000 miles or during annual inspections

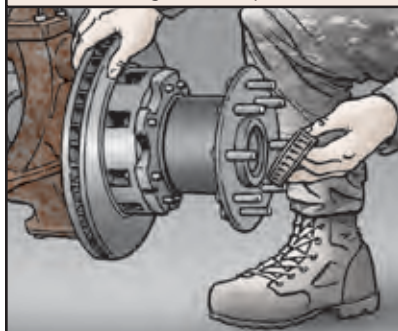

Gunner's Sling NSN?



Dear Half-Mast,

Is there a gunner's sling for the M1151A1 HMMWV? I looked all through TM 9-2320-387-10 and couldn't find one.

PFC Z.G.



YES, PRIVATE, THERE IS A GUNNER'S SLING.

IT'S ITEM 11 IN FIG 298 OF TM 9-2320-387-13&P (IETM EM 0323, MAR 14).

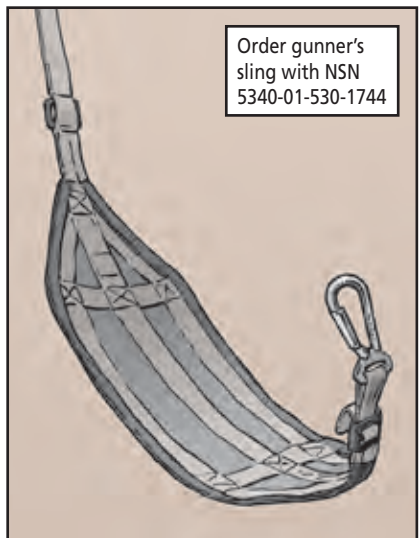

BRING IN THE GLOW!

The door handles and escape hatches inside MRAP vehicles are hard to see, especially in the dark. That's because there's only a slight color contrast between the handles and surrounding area.

Seconds can count on the battlefield, so add a little glow to the situation by adding a strip of *luminous tape*, NSN 9390-01-573-0835, in all the right places.

Inside the MRAP, place the tape on the escape hatches and doors like so:

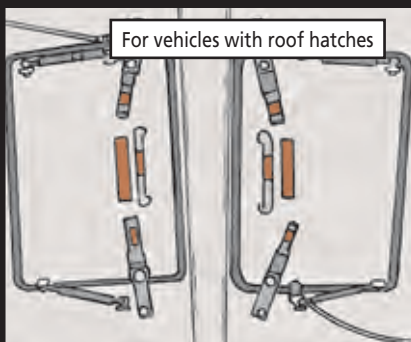
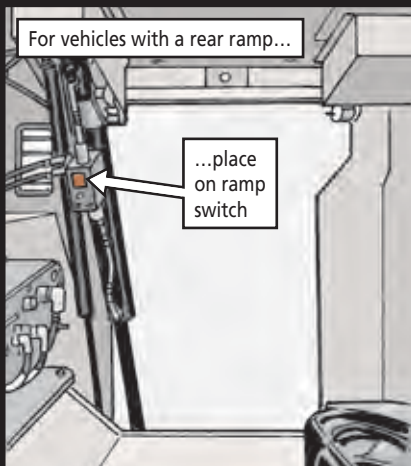
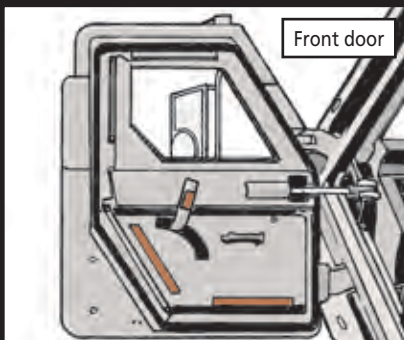

By the way, this tape works on composite and non-metallic surfaces. Just wipe off the area first with some alcohol wipes. Then dry it with a clean rag before applying the tape.

MEDEVAC...

TM Change Coming for External Rescue Hoist Washer

Mechanics, things in aviation can change on a dime. The MEDEVAC Breeze-Eastern commercial manual, TD-01-006, (Rev D, w/changes, Jun 18), included a technical publications deficiency report (TPDR) that replaced one of the hoist hook washers, PN BL-11684-1, with NSN 3120-01-624-2150 (PN BL-11684-2).

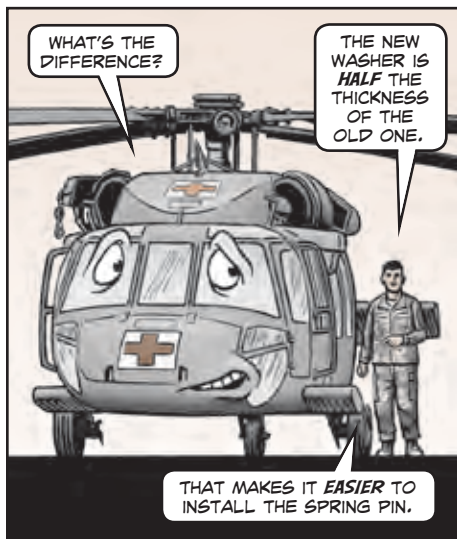
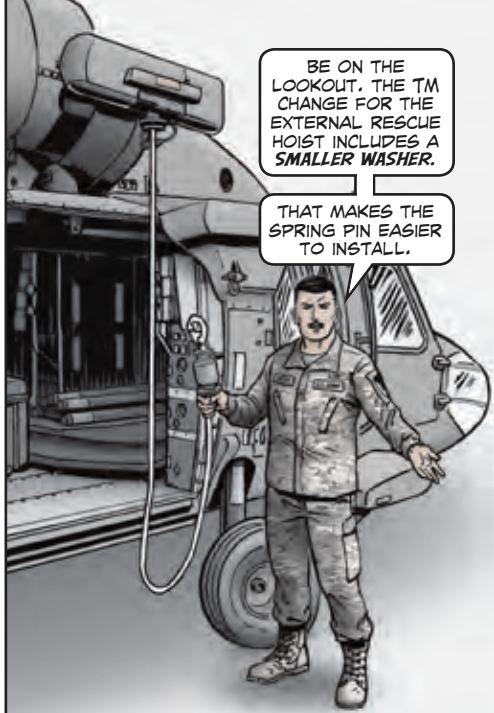

Replacement washer is thinner



New hoists and hook assemblies already have the new washer installed. But the new NSN and part number *haven't* been added to the manufacturer's manual or the aircraft TMs.

The change is in the works. But until it happens, add the new NSN and part number to Item 15 in Fig 4-157 of TM 1-1520-237-23&P and Item 16 in Fig 14-2 of TM 1-1520-280-23&P.

MEDEVAC...

Check Internal Rescue Hoist Lanyards

DID YOU CHECK THE LANYARD TO MAKE SURE IT'S THE RIGHT LENGTH?

THUMBS UP ON THAT. THE LANYARD IS GOOD TO GO!

Mechanics, some time ago, a unit reported damage to the internal rescue hoist drum from a safety clip ingested into the running hoist.

The reason this happened isn't clear. But the clip and lanyard, which were attached to the hoist and designed as a safety for the upper hoist connection, came loose during operation.

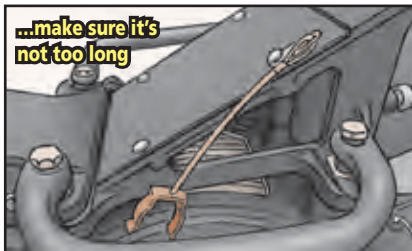
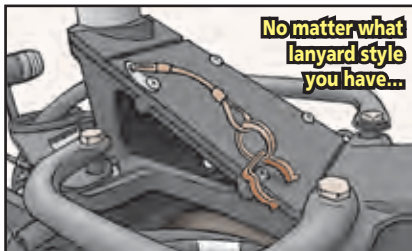

Several different lanyard styles are in current use. No matter which one you have, it's a good idea to check the lanyard for problems. Make sure the lanyard is long enough to allow installation of the clip on the upper hoist connection, but not so long that a free-hanging clip can get ingested into the running hoist.

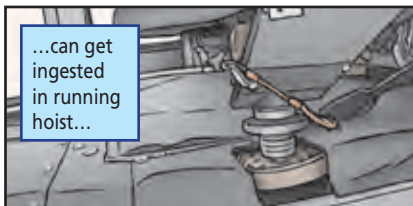

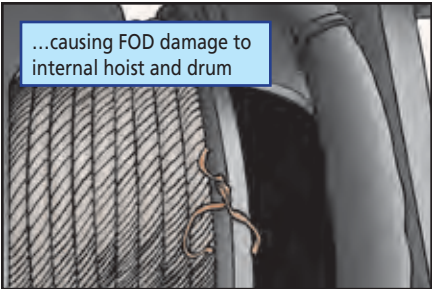

...causing FOD damage to internal hoist and drum

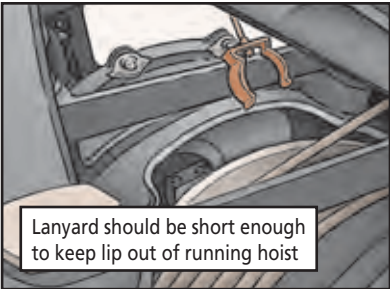

Lanyard should be short enough to keep lip out of running hoist

Check out Item 3 in Fig 2, on Page 122 and Item 2 in Fig 2 on Page 200 of TM 1-1680-320-13&P (Jan 08) for more info.

NOT ONLY CAN A TOO-LONG LANYARD **DAMAGE** THE INTERNAL GEARS OF THE HOIST...

...BUT THOSE GEARS AND THE RETAINER ITSELF CAN **BECOME** A FOD PROBLEM.

Need a MEDEVAC Hoist Briefing?



HEADS UP! PD MEDEVAC HAS AN OPEN INVITATION TO UNITS FOR HOIST BRIEFING TRAINING.

SCHEDULE THEM FOR YOUR SAFETY STAND-DOWN.

Mechanics, if you have an upcoming safety stand-down, PD MEDEVAC will come to your unit to brief users on hoist issues. They'll also provide info on upcoming changes to hoist maintenance-related operational procedures and TM updates.

What does PD MEDEVAC need?

1. An invite
2. A classroom
3. A projector
4. The unit's undivided attention for about three hours

Take advantage and get better informed about MEDEVAC hoists. To request a visit to your unit, email Tracy Hicks at: tracy.d.hicks.civ@mail.mil

Composite Repair Kits Have the *Right Tools!*

WE'RE IN THE MIDDLE OF NOWHERE!

HOW AM I GOING TO GET THE COMPOSITE REPAIRS I NEED?

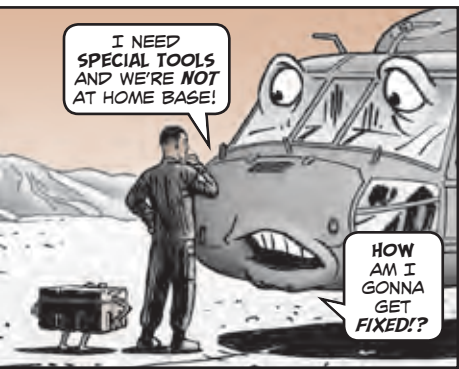

I NEED SPECIAL TOOLS AND WE'RE NOT AT HOME BASE!

HOW AM I GONNA GET FIXED!?

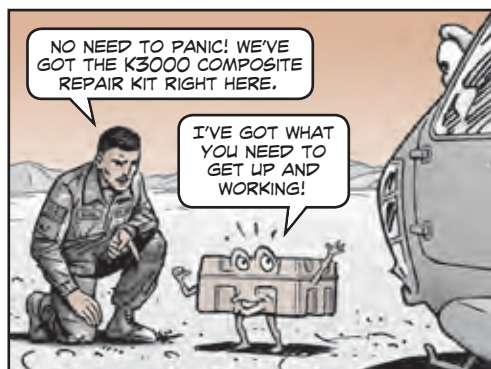

NO NEED TO PANIC! WE'VE GOT THE K3000 COMPOSITE REPAIR KIT RIGHT HERE.

I'VE GOT WHAT YOU NEED TO GET UP AND WORKING!



AIRFRAME MECHANICS, HAVING THE RIGHT TOOLS TO MAKE COMPOSITE REPAIRS IS IMPORTANT.

The K3000 composite repair kit, NSN 4920-01-628-2469, is a portable kit with specialized tools used to make composite repairs while away from a fixed facility.

The PD AGSE folks have integrated the K3000 composite repair kit into two separate aircraft tool sets. In each Aviation Maintenance Company (formerly AVUM), the K3000 is in the Aviation Unit Maintenance Tool Set: No. 2 Airmobile-Enhanced, NSN 4920-01-551-7472.

The composite repair kit is also in each Aviation Support Company's (formerly AVIM) Tool Crib Shop Set, NSN 4920-01-600-7362.

The Aviation Support Companies also have the Composite Shop Set, NSN 4920-01-600-7365, which provides tools and some materials to make higher level composite repairs to aircraft.

REPLACEMENT SEARCHLIGHT NOW AVAILABLE!

The searchlights on UH-60M helicopters have a problem:



TURN ON
THE SEARCH-
LIGHT!

Their light some-
times *dissipates*.



HEY!
THAT'S **NO**
GOOD!

GOOD NEWS!
THOSE OLD
SEARCHLIGHTS,
NSN 6230-
01-556-7911,
ARE BEING
REPLACED.



To prepare for the
new searchlights, follow
these steps:

1. Remove the old searchlight.
2. Take off the searchlight's lens and adapter ring.
3. Tag the lens and adapter ring as an assembly and turn it in using condition code A and ownership purpose code A (serviceable).

Send the assemblies to
Red River Army Depot at:

DLA Distribution Center
(Plant: 7001 RIC: BR4)
Red River Army Depot
Highway 82 West
Texarkana, TX 75507-5000

The new searchlight,
NSN 6230-01-653-9052, *doesn't*
have issues with dissipation.
Deliveries of the replacement
searchlight have already begun
and can now be ordered through
regular supply channels.

Turn in old
searchlight
for new
searchlight



Make a note that the A/L/V
model aircraft still use the *old*
searchlights. Units must continue
to turn in the old searchlight when
they receive the new searchlight.

QUESTIONS
???

Direct all searchlight questions and shipping
questions to **Cheksha Schenck**, at (256) 842-0187
or email: cheksha.m.schenck.civ@mail.mil

BALLISTIC KIT NEEDS NEW PART NUMBER

IF YOUR AIRCRAFT FLY WITH A BALLISTIC KIT, THERE'S AN IMMEDIATE PART NUMBER CHANGE YOU NEED TO KNOW ABOUT!



Mechanics,
IF

your Black Hawk has the Enhanced Ballistic Armament Protection System (EBAPS) kit installed

AND
you're flying under AWR 1752,

CONTACT
the UH-60 Program office for *instructions*.

The kits installed on UH-60 aircraft need to have a *part number change* applied ASAP.

Contact Joe Ingram, (256) 313-2483 or by email: joseph.a.ingram4.civ@mail.mil

Instructions for the part number change will be emailed to you.

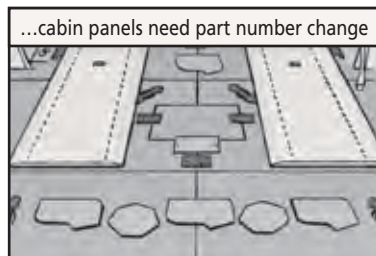
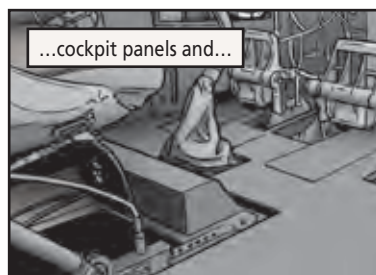

NOW THAT I'M ALL BALLISTIC, I CAN TAKE A HIT IN THE FIGHT!



FLY FAR WITH THESE TIPS

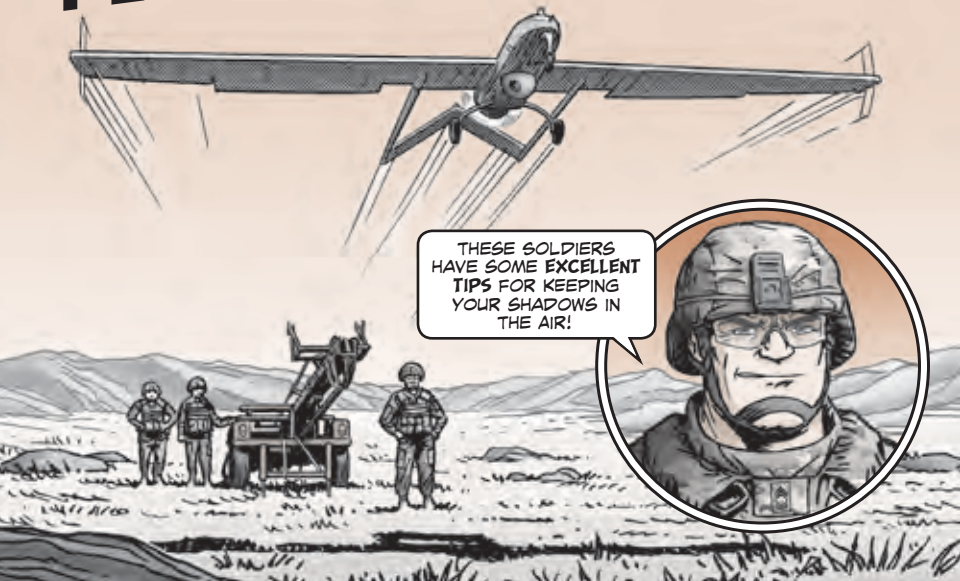

Dear Editor,

We help keep the Shadows flying at Ft Stewart. So we're providing a few tips to keep your Shadows in the air:

- **Use the TM.** There are a lot of checks for the Shadow and its launcher. Missing just one could lead to a crash. So use the TM. It's the only way to ensure you don't miss anything.

Remember, a technical inspector needs to verify and document everything you do, including repairs. That ensures your Shadow has a safe flight and you won't be blamed if something goes wrong.

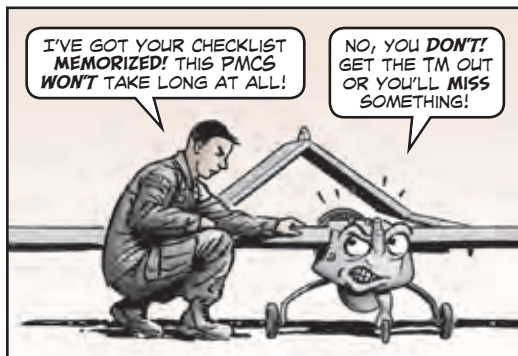

- **Be careful out there.** Just a bump can snap off the pitot tube or the communications relay system (CRS) antenna. Tie warning tags to both to help Soldiers remember to give them a wide berth.

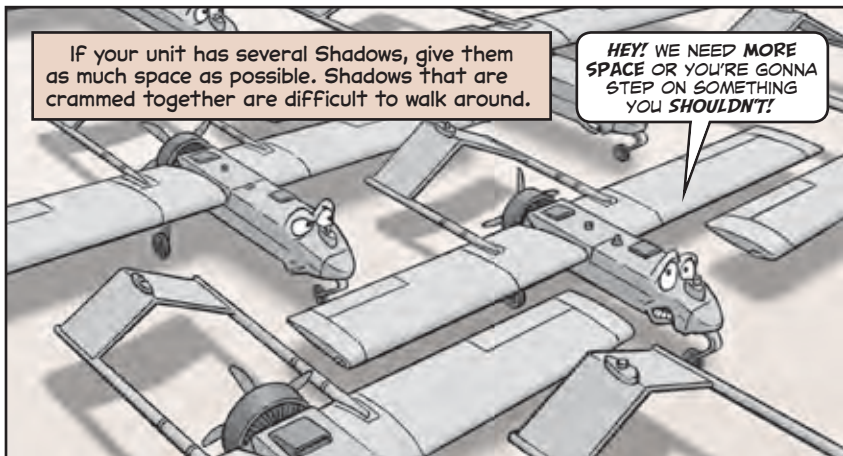
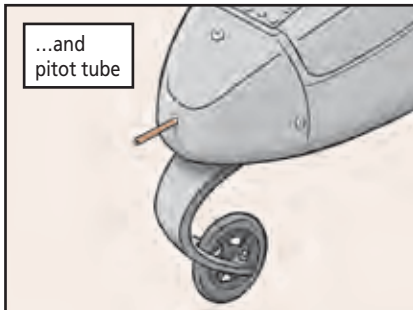
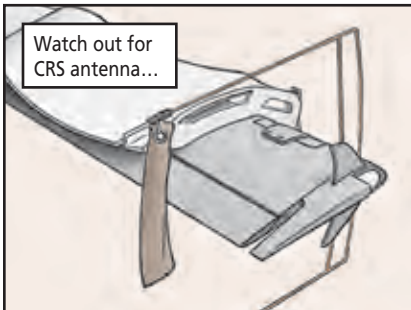

If your unit has several Shadows, give them as much space as possible. Shadows that are crammed together are difficult to walk around.

HEY! WE NEED MORE SPACE OR YOU'RE GONNA STEP ON SOMETHING YOU SHOULDN'T!

Before moving a Shadow, put the propeller in the horizontal position. That prevents the propeller from being damaged hitting the ground.

- **Remember the tactical automatic landing system (TALS) storage pins.** If you forget to remove the pins, they can cause damage when the TALS is turned on.

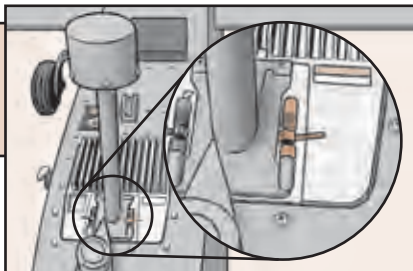

- **Check the oil pressure indicator.** The indicator light must go off before the Shadow is launched. If the light doesn't go off, the oil pressure may be low. Check it out.

Don't forget to remove TALS storage pin

- **Eyeball the oil line for air bubbles.** If any of the bubbles are larger than $\frac{1}{4}$ inch, do the oil pump bleeding procedure. That air bubble could prevent enough oil from getting to the engine.

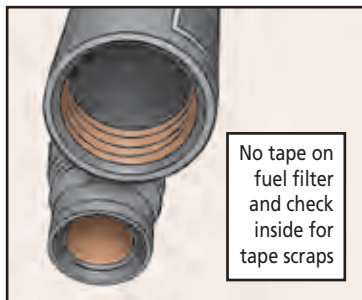
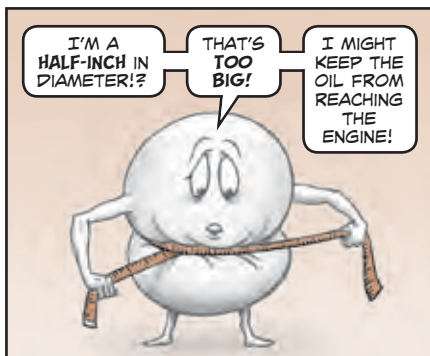

No tape on fuel filter and check inside for tape scraps

- **No tape for fuel filter.** Don't use plumbers' tape on the fuel transfer pumps to keep the filter or fuel lines from leaking. Bits of the tape can break loose and clog the filter. Make sure there are no tape bits in the filter.

- **Do the caliper brake pressure adjustment for arresting gear like it says in the TM.** If you don't properly set the caliper brake pressure to a tolerance of 85 ± 20 lb-ft, the Shadow could have a landing mishap.

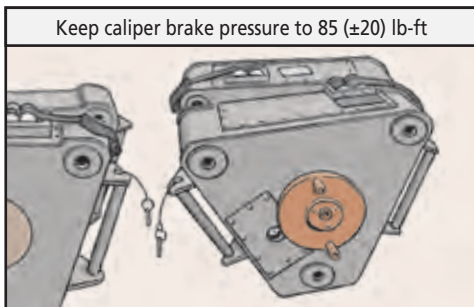

- **Don't forget the launcher.** Pay particular attention to the rails. Check for FOD. Something as small as a pebble could damage the Shadow and the launcher rail.

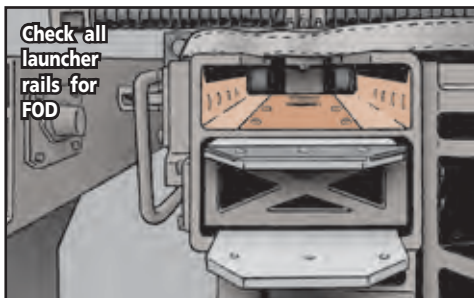

Make sure you've set both brakes and chocked both wheels. Don't forget that the launcher's shovels must be emplaced in dirt. Concrete can snap off the shovels' teeth.

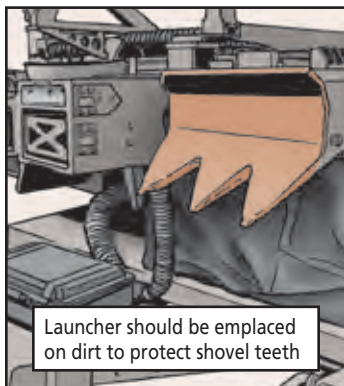
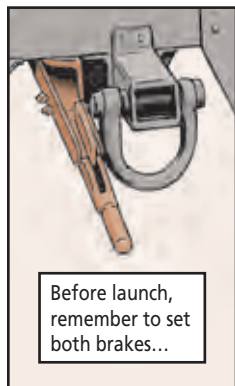

• **Wear safety gear.**

The Shadow is very loud, so wear **double ear protection**. And you don't want the Shadow's fuel on your skin. When fueling it, wear rubber gloves, an apron and eye protection.

SGT Daniel Edwards
SGT Damien Rios
Ft Stewart, GA

Editor's note: *Shadow crews will indeed fly far with your tips, Sergeants. Thanks.*



I CAN'T HEAR YOU 'CAUSE YOU'RE SO LOUD!

WEAR HEARING PROTECTION OR YOU'LL GO DEAF!



THANKS TO THE SERGEANTS AT FT STEWART, I NOT ONLY MAKE IT INTO THE AIR...

...BUT I MAKE IT **BACK DOWN**, TOO!



Crushing the ETM/IETM MSD Conundrum

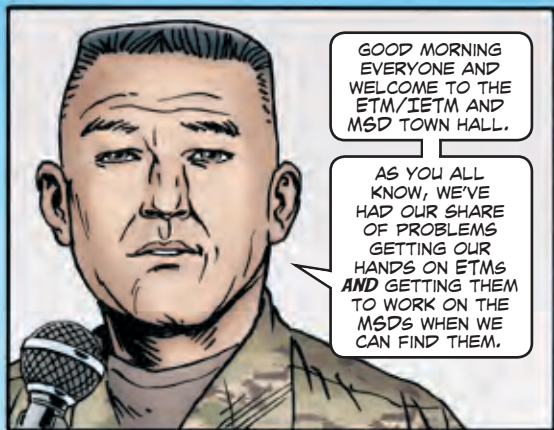

I'D LIKE TO THANK SERGEANT MAJOR PI FOR INVITING ME TO SPEAK WITH YOU ALL TODAY.

I UNDERSTAND THAT THERE HAVE BEEN SOME ISSUES WITH GETTING ETMS/ IETMS TO DOWNLOAD AND GETTING THEM TO WORK ON YOUR MSDs.



HOPEFULLY I CAN ANSWER YOUR QUESTIONS AND DISPEL SOME RUMORS FOR YOU THIS MORNING.

MAKE SURE YOU HAVE A MICROPHONE BEFORE YOU SPEAK SO THAT EVERYONE CAN HEAR YOU.



LET'S GET STARTED. WHO WANTS TO GO FIRST?



GOOD MORNING MASTER SERGEANT. ONE OF THE THINGS WE'RE HAVING TROUBLE WITH IS THE SHORTAGE OF ETMS AND IETMS.

THERE JUST DON'T SEEM TO BE ENOUGH IN THE MOTOR POOL TO GO AROUND. IS THERE A WAY TO GET MORE OF THEM INTO CIRCULATION?



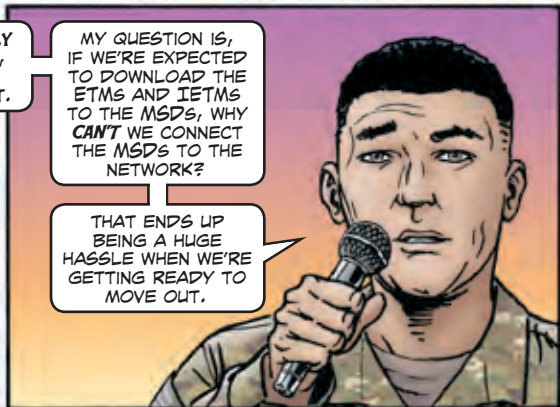
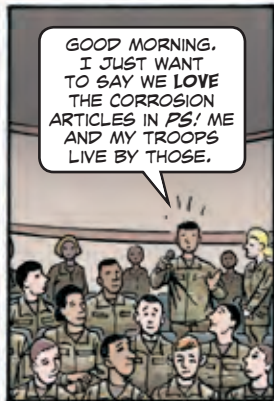
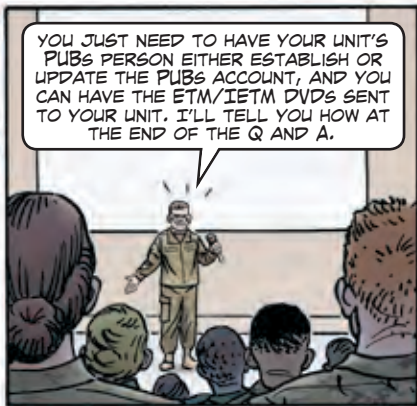



GREAT QUESTION, SERGEANT.

The reason you *can't* connect MSDs to the installation network is because different posts have different security requirements. That presents a challenge.

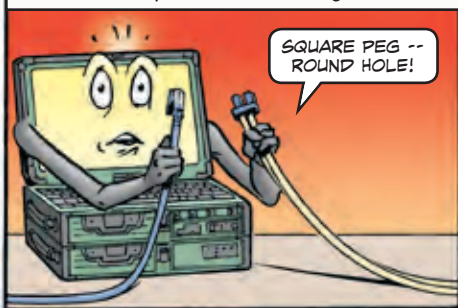

SQUARE PEG -- ROUND HOLE!

One way around this problem is to download the ETM/IETMs on another computer as a ZIP file and burn it to a DVD. From there, you can use the DVD to install the ETMs/IETMs on to your MSDs. This can be pretty time-consuming though, since some of the files are pretty big.

A BETTER SOLUTION IS TO CONTACT THE LOGISTICS DATA ANALYSIS CENTER, LDAC, WHEN YOU'RE ABOUT DEPLOY. LDAC PROVIDES THE PUBLICATION TAILORED INDEX LISTING OR PTIL.

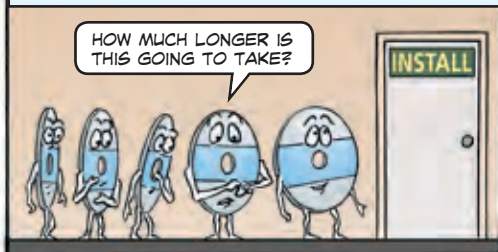

HOW MUCH LONGER IS THIS GOING TO TAKE?



The PTIL is a **complete** DVD set of updated ETMs/IETMs for all of the equipment listed on your MTOE or GCSS-Army.

And, as long as we're talking about the PTIL, LDAC is working on an ETM/IETM library by brigade combat team down to the company level UICs tailored for specific units.



ALL YOU HAVE TO DO IS ASK THEM FOR IT!



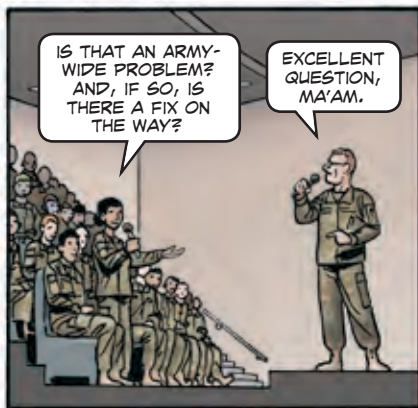
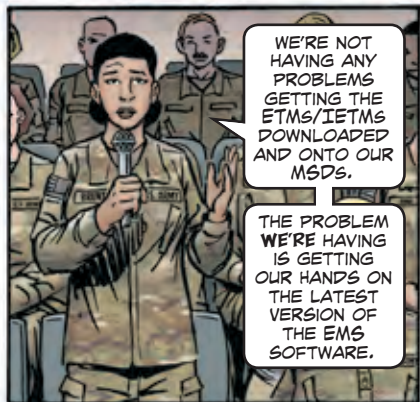
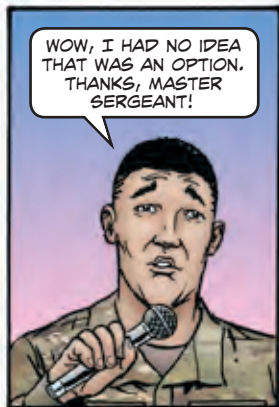



YOU ARE ACCESSING A U.S. GOVERNMENT (USG) INFORMATION SYSTEM (IS) THAT IS PROVIDED FOR USG AUTHORIZED USE ONLY.

The AKO Classic Portal will go into a "READ ONLY" mode as an interim step prior to AKO Classic being sunset on 26 Oct 2014. The "READ ONLY" mode users will still be able to download files but will not be able to upload files.

THE **ONLY** PLACE TO GET THE EMS SOFTWARE IS ON THE ARMY KNOWLEDGE ONLINE, OR AKO, WEBSITE: <https://www.us.army.mil/suite/files/47003349>



You'll have to use your CAC to log in because you *can't* get to the software using just your username and password.

As long as we're on the subject of MSD software, *don't forget* that when you update EMS you'll also have to update the other MSD software as well.

WE MAKE A GREAT TEAM!

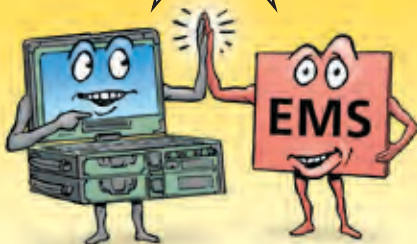

ORDER THE LATEST MSD EMERGENCY RECOVERY DISK-ERD-OR SUPPLEMENTAL SOFTWARE DISK-SSD-THROUGH THE MSD/ICE HELPDESK: apats@redstone.army.mil

OR DOWNLOAD THE LATEST SSD FROM THE MSD REPOSITORY: <https://cmtool.army.mil>



click!

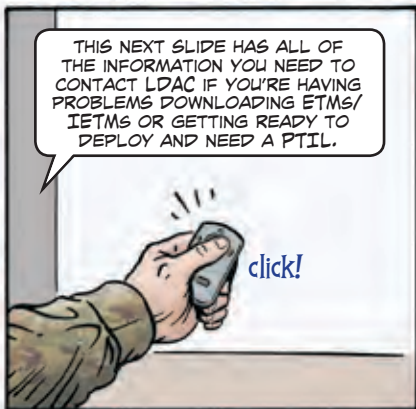

IT ALSO HAS THE CONTACT INFORMATION FOR THE MSD/ICE HELPDESK IF YOU HAVE ANY QUESTIONS ABOUT THE MSDS.

IT'LL BE AVAILABLE ON SHAREPOINT RIGHT AFTER WE FINISH.

THANKS FOR YOUR TIME THIS MORNING.
HOOAH!



THANKS, MASTER SERGEANT HALF-MAST, FOR STOPPING BY TODAY.



LDAC ETM and PTIL Website



<https://liw.logsa.army.mil/etmapp/#/etm/home>

Email questions to:

usarmy.redstone.logsa.mbx.logetm@mail@mil

EMS Help Desk:

support@ems-helpdesk.com

MSD/ICE Help Desk:

apats@redstone.army.mil

HELLFIRE Missile System...

GET FIRED UP WITH PM!

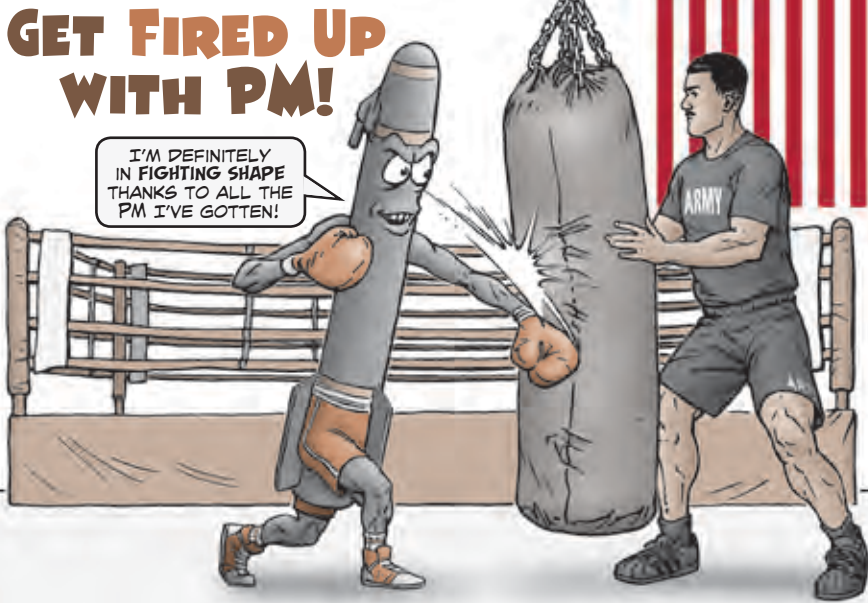

I'M DEFINITELY IN FIGHTING SHAPE THANKS TO ALL THE PM I'VE GOTTEN!



HELLFIRE MISSILES CAN DO SERIOUS DAMAGE IF **BOTH** THE LAUNCHER AND MISSILES ARE IN FIGHTING SHAPE.

BUT IF *EITHER* ONE IS SUFFERING FROM **NEGLECT**, YOUR HELLFIRE FIRING JUST WENT TO **ZERO**.

KEEP YOUR HELLFIRES **FIRED UP** FOR FIRING WITH THIS PM!

Launcher

Use **shotgun connector covers**. If the covers are left sticking up, dirt and sand plug up the connectors and kill the electrical connections to the missiles. Make sure they're working properly and are aligned right. If the covers aren't completely sealing the connectors, tell your repairman. He can adjust them.

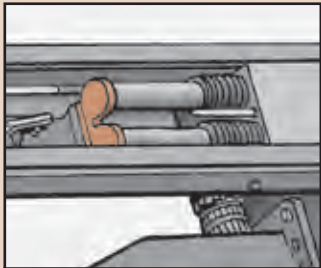

Make sure shotgun connectors close completely

Launcher, continued

Clean shotgun connectors. The connectors still need to be checked for dirt before a mission. Use a flashlight to look for dirt in all four sets of connectors. If you find any, use a clean wiping rag dampened with water and **detergent**, NSN 7930-00-282-9699, to clean out the dirt. Remove dirt and debris from the exterior surfaces. Don't clean inside the connector with water. Use low-pressure air to blow out any dirt in the connectors.

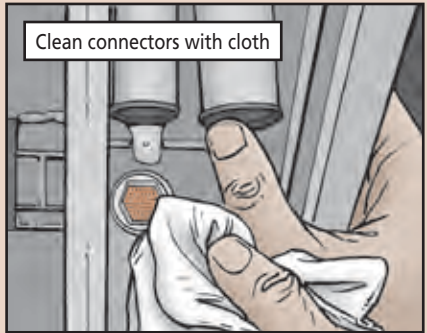

Check for burrs and corrosion. Burrs and corrosion on the inside of the launcher rails make it difficult to load missiles. Look for burrs and corrosion whenever the launcher is removed or installed. Eyeball each rail inner surface for roughness or notching. Damage to the inside of the rails can't exceed a maximum of .007 inches.

Clean off corrosion following the procedure in TM 1-1500-344-23. Never file or sand the launcher. The plating residue can be dangerous if it gets in your lungs. Filing and sanding also cause dirt and sand to collect on the rails, which causes more loading problems.

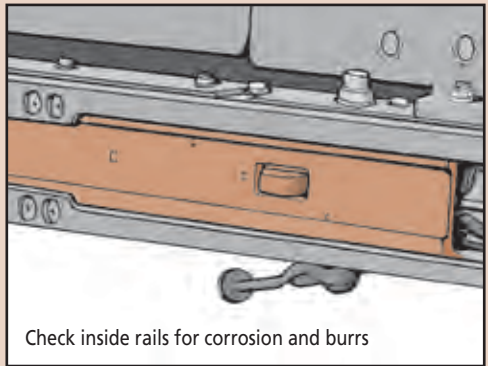

Don't lube the launcher. That just causes dirt and sand to collect on the rails, which causes even more problems.

Loading

No jamming. If you slam a HELLFIRE into place on the launcher, you'll probably damage the stop blocks or the intermediate shoe, plus the missile itself.

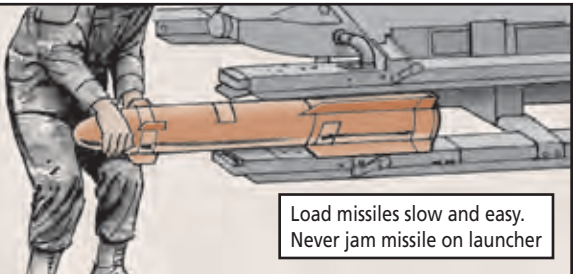

Loading, continued



A HELLFIRE SHOULD SLIDE **EASILY** INTO PLACE. IF IT DOESN'T, SOMETHING IS PROBABLY **WRONG** WITH THE LAUNCHER, MISSILE SHOES, OR UMBILICAL CONNECTOR.

DON'T TRY TO LOAD A DIFFERENT MISSILE. TELL YOUR REPAIRMAN.

The correct way to load is to place the latch handle to UNLATCH. Slide the missile slowly down the rail until the forward shoe is engaged in the rail track and the missile contacts the stop blocks. Move the handle to LATCH while holding the missile in place.

Make sure the latching handle actually latches. The handles get beat up from feet and bumps and they quit working. When the missile is latched, the handle shouldn't move more than 10 degrees. If it moves more, the handle may be damaged. Tell your repairman.



Missiles

Protect 'em. HELLFIRE missiles need all the protection you can give them. Keep them in their storage containers as much as possible.

If you have access to dome covers, use them.

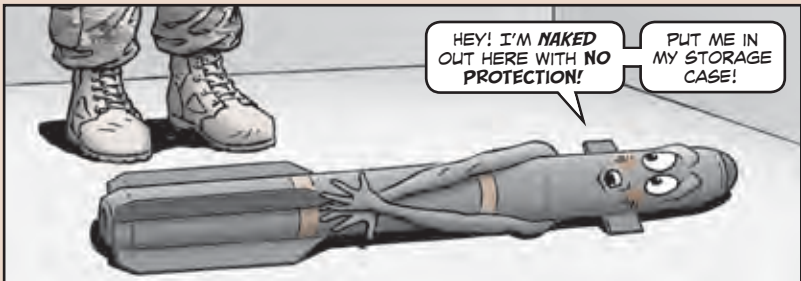

Don't use the fins as handles. They break and that puts the missile out of action. Hold the body of the missile to guide it into place on the launcher.

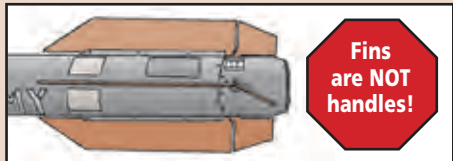

SIGHT IN ON THESE SIGHT TIPS



GEEZ! WHAT'S WITH THE REFLECTION? ARE YOU TRYING TO TELL THE ENEMY WHERE TO SHOOT?



HEY, MAN, DON'T BLAME ME! YOU'RE THE ONE WHO TOOK OFF MY ANTI-REFLECTIVE CAP.

Here are a few ways to help your M68 reflex sight keep you on target:

- Easy does it with the windage and elevation adjustment caps. Some Soldiers crank the caps so hard that the whole cap breaks off. Often the only fix is to replace the whole sight. Once the cap doesn't want to turn more, stop turning.

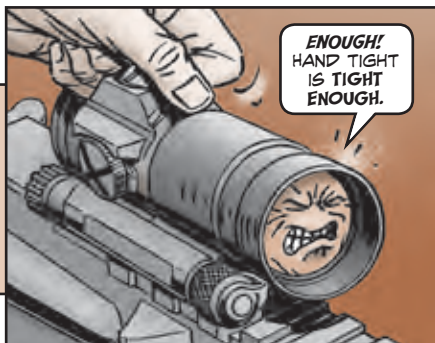

- Don't use your shirt as a cleaning instrument. The M68 has delicate lenses that can be quickly scratched up by something as rough as your shirt. If you can't see through the lenses, the sight is no good. Your armorer should have lots of lens paper made specifically to clean delicate sights. Get a pack and store it in your pack. If your armorer needs more lens paper, he can order a pack of 100 tissues with NSN 6640-00-240-5851.



- Make sure you're using TM 9-1240-413-13&P (May 13). It replaced TM 9-1420-413-12&P, which doesn't cover the newer M68 versions.

- **Don't remove the anti-reflective cap.** Soldiers often remove the cap because that makes it easier to use the backup iron sight (BUIS). But the cap serves two critical functions:

1. It prevents a reflection from signaling your position to the enemy. That could mean the difference between life and death on the battlefield.
2. It protects the M68's lens from scratches. If the lens gets too scratched, it's unusable.

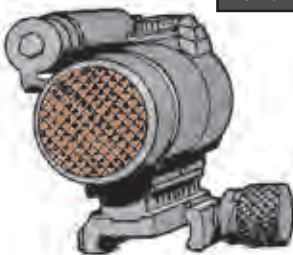

Don't remove anti-reflective cap

Here are the NSNs for the M68 models:

- **CompM2,**
NSN 1240-01-411-1265
- **CompM4,**
NSN 1240-01-540-3690
- **CompM4S,**
NSN 1240-01-576-6134

M249 Machine Gun...

**CAN
BARREL
COLLAR
MOVE?**

WELL, MY
BARREL COLLAR
IS MOVING ONLY
A LITTLE BIT.

DOES THAT
REALLY MEAN
I NEED A NEW
BARREL?

YEP!



Dear Half-Mast,

PMCS Step 2 in TM 9-1005-201-23&P says to check the M249 machine gun's barrel carrying handle collar for any movement. But it doesn't say if any movement is just a deficiency or if it makes the barrel non-mission capable (NMC). Can you clarify?

SPC K.H.

SURE THING,
SPECIALIST. ANY
MOVEMENT OF
THE COLLAR
MEANS YOU NEED
A NEW BARREL.



Any movement of
barrel collar means NMC

Feed Box Support Kit UPDATE

I THINK I NEED THE FEED BOX SUPPORT IMPROVEMENT KIT.

GOOD NEWS! THE KIT HAS AN NSN NOW. WE'LL GET YOU FIXED UP IN NO TIME.



Page 19 of PS 793 (Dec 18) talked about the importance of making sure your M249 machine guns have the feed box support kit installed.

Now you no longer need to contact TACOM if your M249s need the kit. The kit can be ordered with NSN 1005-01-560-1026 and installed by a 91F small arms repairman.



HOW DO YOU KNOW IF YOUR M249S NEED THE KIT?

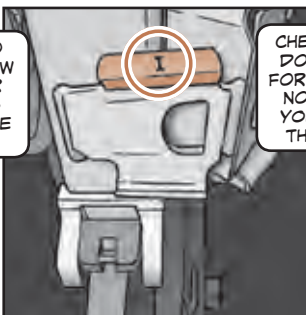

CHECK THE DOVETAIL FOR AN "I". NO "I"? YOU **NEED** THE KIT!



For installation instructions, see PS 793 at:
<https://www.logsa.army.mil/web2/archive/PS2018/793/793-19.pdf>



DURING PMCS, GUNNERS SHOULD CHECK THE KIT'S SCREW FOR LOOSENESS.

OVER TIME, THE SCREW CAN WORK LOOSE AND FALL OUT.

Small arms repairmen, fix a loose kit screw by removing the hexagon head cap screw and cleaning it.

Then follow the instructions in PS 793 for reinstalling the kit.

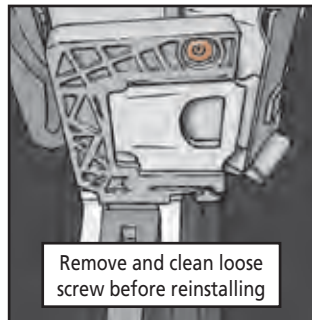

Remove and clean loose screw before reinstalling

CCMCK Strikes Again

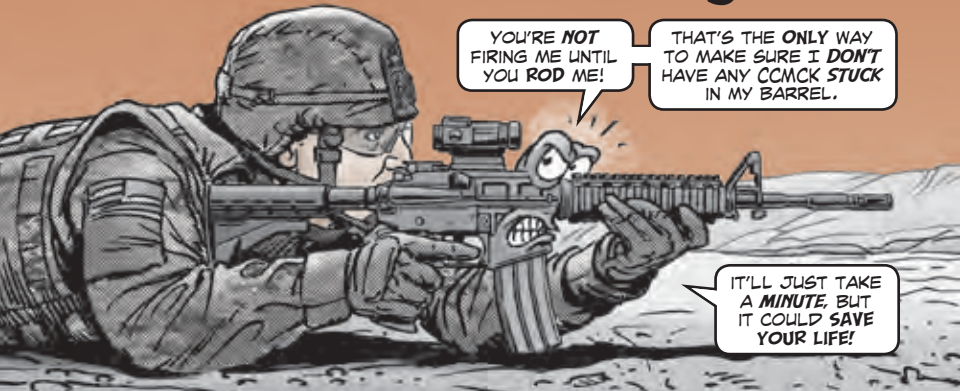

Pages 36-37 of PS 795 (Feb 19) spelled out the **dangers** of not thoroughly cleaning your weapon after firing close combat mission capability kit (CCMCK) projectiles.



CCMCK ROUNDS CAN LEAVE AN ALUMINUM SLEEVE **STUCK** IN THE BARREL.

If the sleeve *isn't* pushed out, the barrel is **plugged**.

If the weapon is fired with a plugged barrel, it **blows up**.

And that's exactly what happened earlier this year.

A Soldier fired an M4 carbine that had a CCMCK sleeve lodged just behind the flash suppressor.

The weapon blew up and **both** the Soldier firing the weapon...

...and the Soldier standing next to him were injured seriously enough that they had to be flown to a hospital.

IT'S **VITAL** THAT SOLDIERS DO THE CLEANING AND CHECKS SPELLED OUT IN PS 795.

You can review the story at:

<https://www.logsa.army.mil/web2/archive/PS2019/795/795-36-37.pdf>



But to be doubly sure such a catastrophe **doesn't** happen again, units should make the rodding of weapons **before** they're fired at the range **mandatory**.

That's the **best** way to ensure no weapon with an obstructed barrel is fired.

See <https://www.logsa.army.mil/web2/archive/PS2018/784/784-38-39.pdf> for instructions on how to check for obstructions in the barrel.

PART STUCK? NEVER REACH FOR ACETYLENE TORCH!

Dear Editor,

In my work as a LAR, I've seen several instances of repairmen using an acetylene torch to loosen stuck parts. Specifically, they've used a torch on stuck mortar breech caps, jammed M2 machine gun barrels and various artillery systems components.

This results in major damage to the equipment. It melts the metal and sends equipment to the junkyard.

Acetylene torches should **never** be used at field support to loosen any stuck part.

Repairmen who can't get a stuck part unstuck should send it to the next level of maintenance.

But never reach for an acetylene torch.

Andrew Guilliams
Ft Sill, OK

An acetylene torch
can do tremendous
damage!

Editor's note: *This is clearly an instance where the easy way is the **wrong way**. To say the least, no repairmen should do anything that's not called out in the TM, especially if it involves torches.*



Don't Let JSGPM Carrier Get Carried Away

The joint services general purpose mask (JSGPM) comes with two carriers: the **chemical-biological mask carrier**, NSN 8465-01-529-0599, and the **individual carrier**, NSN 8465-01-529-1397.

Both carriers rarely wear out. But units are ordering a surprising number of replacements. They aren't budget busters—the mask carrier costs \$52 and the individual carrier \$36—but the more units have to order, the faster the dollars add up.

One cause may be the carrier gets misplaced when it's not used and then is never seen again.

One way to stop carriers from disappearing is by keeping the carrier safely stored in a locker or trunk when not in use. Keep the locker or trunk in the CBRN room. Make sure each carrier is tagged with its mask's serial number so it's easy to match the carrier with its mask.

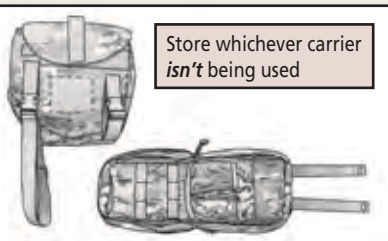

TMDE... **KEEP CURRENT WITH CALIBRATION**

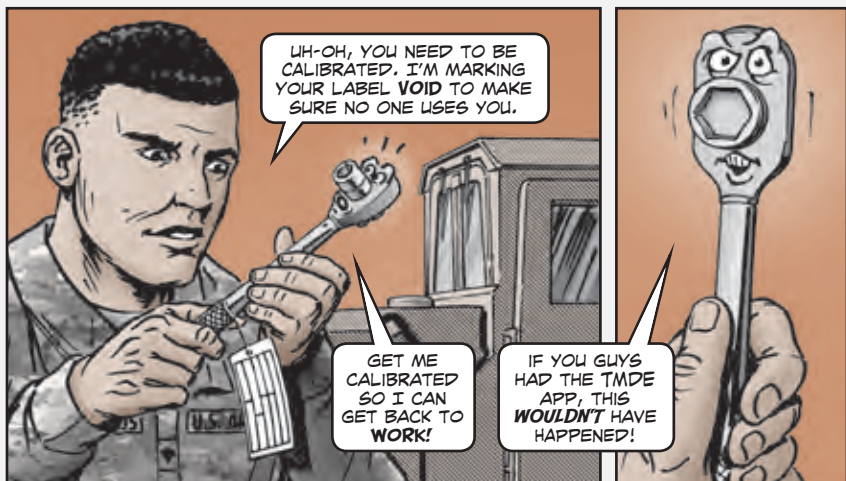

Dear Editor,

At the Ft Stewart command maintenance evaluation and training team (COMET), we run across tools whose calibration deadline has passed. That means these tools can't be trusted to give an accurate reading. An inaccurate reading can lead to disaster in some cases.

To ensure that tools aren't used until they're calibrated, we tell mechanics to write VOID in large letters on each tool's DA Form 80 TMDE sticker. And, of course, get them calibrated ASAP.

Ricky Sammons
Ft Stewart, GA

US ARMY CALIBRATED INSTRUMENT	
DATE CALIB	BY CALIB
7 FEB 22	WNGEN
6 JUN 22	IS
4. IDENTIFICATION NO.	OWNER

DA LARE NO. 1 DEC 77 REPLACES BOTTOM OF 1 JAN 70 WHICH IS OBSOLETE

Calibration deadline expired? Mark TMDE form VOID and get tool calibrated ASAP



PS MORE



HERE'S WHAT THESE REPORTS TELL YOU!

The **master list** shows all your unit's enrolled TMDE items by serial number, model, nomenclature, status and calibration due date.

The **projected items report** lists all TMDE due for calibration in the next 30 days.

The **delinquent items report** IDs equipment past due.

The **in-shop status report** gives the work order number and status along with the model, serial number and nomenclature of your items at TMDE.

To get the app, go to <https://idmng.armyerp.army.mil/>

Login with your CAC. If you're new to AESIP, click on New User Registration and fill out the form.

Scroll to the bottom of the page and click on App Warehouse.

App Warehouse

Keyword Search: Business Area: Application Category: Filter:

Apps Available: 1

Test Measurement and Diagnostic Equipment(TMDE)

TMDE provides users with the ability to view Master, Proposed, Delinquent, and In Shop Status Reports for TMDE items.

In the keyword search, type **TMDE**.

When the TMDE app appears, click **Create Shortcut**.

Amy Enterprise Portal

Welcome to AESIP

TMDE ENERGY

Then close the page and click on the **TMDE** app to get started.



STAY CURRENT WITH CALIBRATION FOR THE GOOD OF YOUR EQUIPMENT... AND YOUR SAFETY!



CREEEEAKE!

HEY,
YOU...
YEAH,
YOU!

LUBE THE HATCH HINGE

I COULD
REALLY
USE SOME
LUBE ON
THAT HATCH
HINGE!

Operators, keep this PM tip in mind 'cause it's a real noggin' saver!
Without lube, condensation gets into the hatch hinge assembly's internal spring, creating rust. The spring weakens until it finally breaks. Then the hatch cover can fall on your head!

There are **two grease fittings** that lube the assembly's internal spring. They're shown in Note 16 of WP 0076-25 in TM 5-2350-262-10 (Jun 12).

Give each fitting **four or five pumps** of GMD quarterly.

BAD NEWS, THOUGH. GMD IS MISSING FROM THE EXPENDABLE AND DURABLE ITEMS LIST IN WP 0082 OF TM 5-2350-262-10.

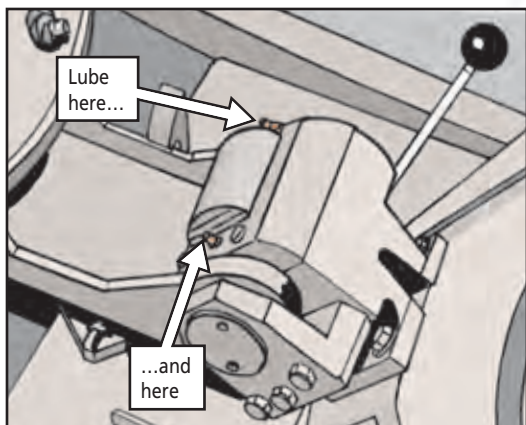

Until these NSNs are added, order GMD from this list:

Size	NSN 9150-
14-oz cartridge	00-935-4018
1.75-lb can	00-754-2595
6.5-lb can	00-223-4004
35-lb can	00-965-2003

HYEX...

STOP THE CHATTER CLATTER!

CHATTER-CLATTER-CHATTER-CLATTER-CHATTER-CLATTER

HELP!
I NEED
THE RIGHT
AMOUNT
OF LUBE!

THE RIGHT
AMOUNT
OF
LUBE WILL HELP
KEEP THOSE
GRITTY GREASE
GREMLINS AWAY.
BUT...



...TOO MUCH
LUBE CAN DAMAGE
THE SEAL AND LET
IN MORE DUST,
DIRT, SAND, AND
WATER.

Operators, old grease that's contaminated by sand and dirt will chew up the teeth on your hydraulic excavator's swing bearing ring gear.

And by the time you hear the sound of gears chattering and grinding while traversing, the damage is *already* done! The ring gear's teeth are worn, repairs are needed and costs are high!

Put a gag on the HYEX's chatter by removing the swing bearing's access cover to check the ring gear. Look for grease with a lot of grit buildup. If you find a heavy coating with a lot of crud, wipe it all off with a clean rag.

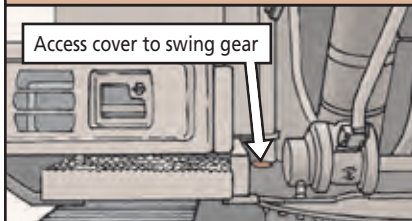

Access cover to swing gear

Add new grease until it reaches $\frac{1}{2}$ - to 1-inch deep from the bottom of the ring gear. Too much grease can *damage* the swing gearbox seal. Remove any grease that's over the top of the swing drive pinion.

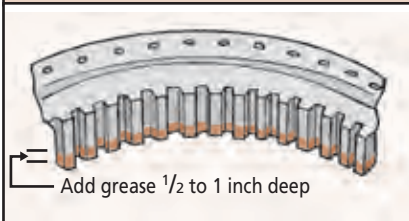

Add grease $\frac{1}{2}$ to 1 inch deep

You'll find this info on Page 15-2 of TM 5-3805-280-10 (Feb 00).

Cab Safety Paramount



GETTING IN AND OUT OF THE 120M GRADER'S CAB MAY SEEM ROUTINE...

...BUT THAT'S WHEN ACCIDENTS HAPPEN!

Operators, keep these safety reminders front and center before you hop into your 120M road grader's cab for the day's run:

- Use three points of contact (two hands and one foot, or one hand and two feet) at all times when getting in or out of the cab.
- Make sure you face the vehicle when using the cab's ladder. Climbing while facing away from the vehicle is an accident waiting to happen!
- Keep the ladder's steps clean. Mud and dirt make the ladder slippery. Another accident waiting to happen!
- Never try to enter or exit a moving vehicle.
- Don't carry tools, supplies or other items when entering the cab. Instead, have someone hand them up to you after you're seated. The same holds true for exiting the cab.
- Controls aren't handholds! Don't touch them until you're ready to operate the grader.

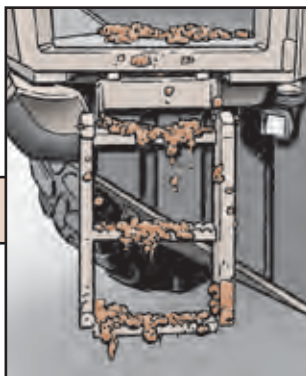

YOU'LL FIND THESE AND OTHER SAFETY POINTERS LISTED IN THE WARNING NOTE IN WP 0005-2 OF TM 5-3805-293-10 (DEC 10).

THAT'S INFO I SURE COULD'VE USED YESTERDAY!



Hummin' the Radio Installation Blues

INSTALLING THAT
RADIO WOULD BE
A LOT EASIER IF
YOU'D READ PS
MAGAZINE!



Dear Half-Mast,

I've been trying to install the **AN/VRC-104(V)5** system, NSN 5820-01-575-9257, in our HMMWVs. But I've found no information on how to do it. I've only got the antenna coupler and whip antenna user manuals from Harris. And they **aren't** useful for installing the system in vehicles.

Can you point me to any TMs or TBs specifically written for this installation? System component block diagrams and parts lists would be really helpful.

SGT D.M.

Dear Sergeant,

I asked my friend at the CCDC C5ISR Center to help out with this one. He says the radio installation kit you need is **Harris #11080-4100-03**, NSN 5895-01-551-6478. Cost runs about \$2,400.

As for the radio installation instructions, you'll need Harris installation training manual 10515-0388-4500. You can get it from Harris, but we've also uploaded it to our milSuite group at: <https://www.milsuite.mil/book/groups/ps-magazine>

TM 11-5820-1501-13&P (May 13) also has maintenance info for the AN/VRC-104(V)5. You'll need to log in with your CAC to view this TM since it's restricted, but you can do a pub number search with the ETM app. Go to:

<https://idmng.armyerp.army.mil>

Half-Mast

EXHAUSTED BY MUFFLER GASKET HUNT

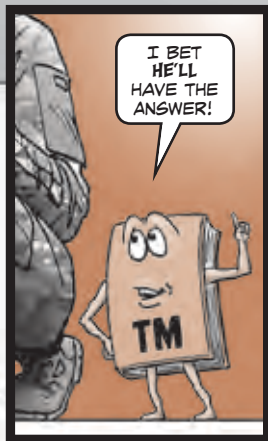
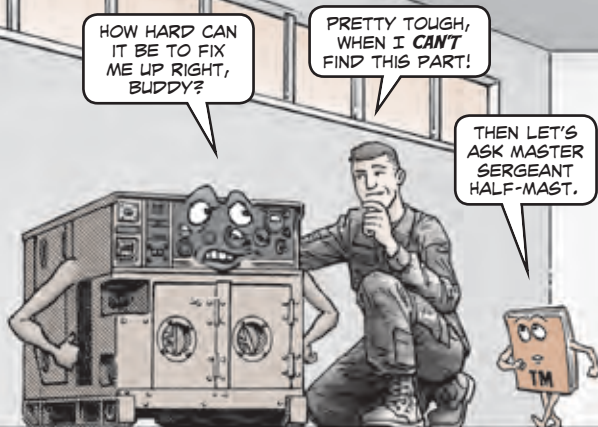

Dear Half-Mast,

Our unit has an **MEP-802A 5-kw tactical quiet generator (TQG)**, NSN 6115-01-274-7387, that needs an exhaust muffler gasket.

It's the only part in TM 9-6115-641-24P (Nov 12) that **doesn't** have an NSN. It's listed as Item 5 in Fig 14 with PN 88-20108.

I've tried FED LOG and MMO3 in GCSS-Army to find an NSN. Nothing comes up. **Help!**

SSG F.R.

Dear Sergeant,

That's why PS exists. PS stands for Post Scripts to TMs, which means we solve dilemmas like this one.

Use NSN 5330-01-390-5185 from TM-6115-642-24P (Oct 96). Note this change in the newer TQG TM, so you have it for the future.

The gasket is usually an authorized stockage list item, and there are plenty of them ready to issue.

Half-Mast

Security Rules in ICIDS-V TM

TM 5-6350-307-10 (Jan 19) is the new operator manual for the integrated commercial intrusion detection system-V (ICIDS-V). The ICIDS-V monitors and controls personnel entry into Army areas and facilities.

TM distribution is restricted, so you'll need to log in with your CAC to:

<https://idmng.armyerp.army.mil/>

Choose the "ETM/IETM" app and search for the TM.

DON'T LET EMPTY GAS CYLINDERS SIT!

TURN 'EM IN!



HEY, WE'RE
EMPTY OVER
HERE!

TURN US IN
SO WE CAN BE
REFILLED AND
GET BACK TO
WORK!



UNITS **AREN'T** TURNING
IN GAS CYLINDERS
WHEN THEY'RE EMPTY.



THAT MEANS THE
ARMY HAS TO BUY NEW
CYLINDERS JUST TO
FILL ORDERS.



THAT'S A **WASTE**
OF MONEY AND MAKES
IT HARDER FOR UNITS
TO GET REFILLS.



WHAT IF WE ONLY
HAVE ONE EMPTY
CYLINDER?



TURN IT IN. **ANY** COMBINATION
OF CYLINDER TYPES CAN BE
TURNED IN TOGETHER.

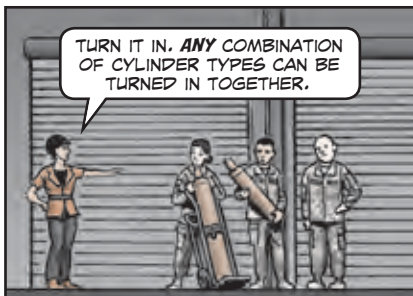

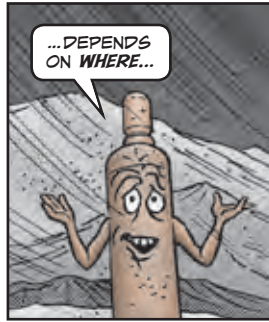
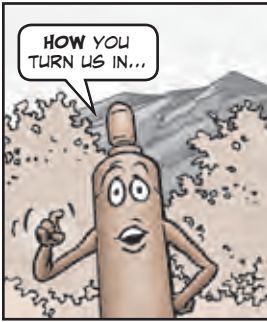

Turn-in instructions are at the DLA-Aviation gas website:

<https://www.dla.mil/Aviation/Offers/Products/Commodities.aspx>

Look under CONUS Industrial Gases and Cylinders Privatization Program.

You'll find not only turn-in help, but also gas and cylinder NSNs and program facts.

DLA-Aviation's gas program covers:

- acetylene
- argon
- carbon dioxide
- helium
- refrigerants
- and more!

HERE'S WHAT THE GAS PROGRAM CAN DO FOR YOU...



- Supply compressed and liquefied gases in a variety of cylinder sizes.
- Deliver full cylinders to your unit. Products usually ship in one to three days, depending on priority, after your order is received.
- Charge for the gas only. There's no extra charge for returnable, reusable cylinders.
- Pick up empty, reusable cylinders from your CONUS site (in most cases).
- Recertify and refurbish cylinders. Customer unit prices include this service.
- Forecast your gas needs and maintain a ready-to-ship inventory based on your demand history.
- Provide safety data sheets (SDS) through the Hazardous Materials Information Resource System (HMIRS).
- Manage wholesale inventory.

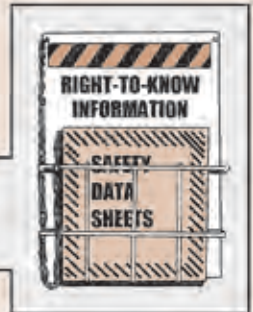

If you have questions about cylinder returns, email: cylreturns@hudsontech.com

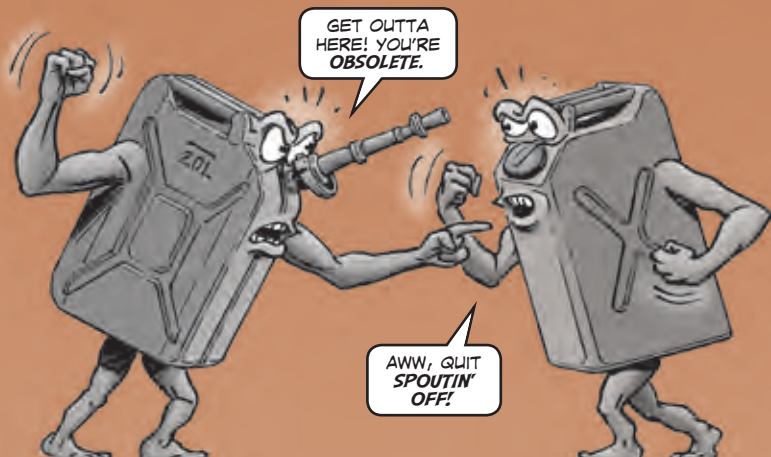

FUEL AND WATER CAN FACTS

Dear Half-Mast,

I see people using plastic cans for fuel, but I find no listing for them on wheeled vehicle hand receipts. I suspect they are, in fact, water cans.

Also, the authorized NSN for the **steel fuel can**, NSN 7240-00-222-3084, is not listed in TM 10-7200-200-13, (Feb 74), which is the only TM I'm aware of that covers fuel or water cans. So:

1. Which TM covers the current NSNs for plastic and steel fuel cans?
2. Which NSN gets a plastic fuel can?
3. How should plastic fuel cans be marked for diesel and gasoline use?

Mr. G.D.

THE OLD STEEL DOT-5L JERRICAN IS **NO LONGER AUTHORIZED** FOR MILITARY FUEL TRANSPORTATION, SIR.

Since 1990, the plastic United Nations (UN) specification jerrican replaced the metal jerrican (49 CFR Section 173.203(c) and AFMAN 24-204(I) A7.2.6).

We haven't found a specific TM for the plastic UN specification jerrican. As you noted, TM 10-7200-200-13 is dated and *doesn't* address the UN specification jerricans.

HERE ARE THE **ONLY** AUTHORIZED ITEMS FOR BII:

Description, Cage Code, and PN	NSN 7240-	Qty
Can, gasoline (81349), MIL-53109	01-337-5269	3
Can, water (81349), MIL-C-43613 Type 1	00-089-3827	6



MIL-STD 290 REVISION H AND MIL-STD 129R REQUIRE MARKING THE PRODUCT NAME ON THE CONTAINER.

We haven't found any specific regulatory guidance that requires gasoline cans to have red-painted caps and the diesel/JP-8/JP-A cans to have yellow-painted caps, though we've seen this in practice.

There may be formal guidance in some states, but it may also be historical practice and SOP-driven.

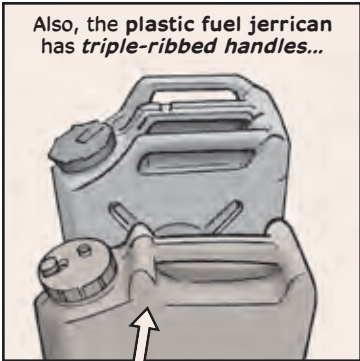

Also, the plastic fuel jerrican has *triple-ribbed handles*...

...while the water can has a *single-rib handle*.

This is so users can tell the difference in the dark.

Medical Repair Parts in GCSS-Army



MASTER SERGEANT HALF-MAST, I'VE GOT SEVERAL MEDICAL REPAIR SHOPS TO MANAGE.



ARE WE NOW ABLE TO ORDER CLASS VIII MEDICAL REPAIR PARTS THROUGH GCSS-ARMY?

IF NOT, DO YOU KNOW *WHEN* WE'LL BE ABLE TO?



REGARDING YOUR FIRST QUESTION, CHIEF, THE ANSWER IS *NOT* YET. AND I DON'T KNOW WHEN BUT WE'RE MAKING PROGRESS.



The need for interoperability factors into this uncertainty.

Medical units must function jointly, and medical logistics systems have to meet multi-service requirements.

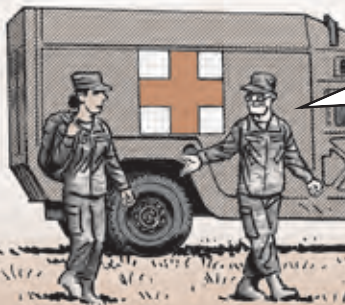

WITH THAT SAID, A GOOD FRIEND AT USAMMA, THE US ARMY MEDICAL MATERIEL AGENCY, TELLS ME THEY'RE WORKING TO INTEGRATE BETTER WITH GCSS-ARMY, WHERE AND WHEN IT MAKES SENSE.

USAMMA has also started an initiative to centrally purchase and store commonly needed medical device repair parts.

IF YOU'VE EXHAUSTED ALL SUPPORTING SUPPLY CHANNELS, YOU CAN ORDER REPAIR PARTS DIRECTLY FROM USAMMA.

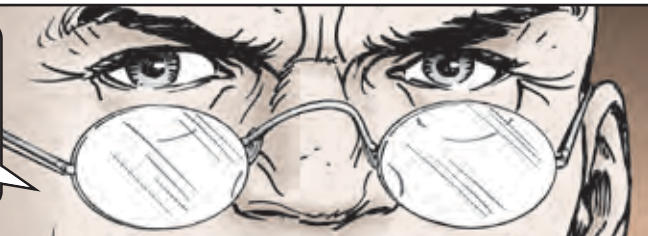

Complete this form: <https://www.milsuite.mil/book/docs/DOC-561973>
Email the form to: usarmy.detrick.medcom-usamma.list.m3d-parts-order@mail.mil

IMPORTANT:

USAMMA will *only* purchase repair parts connected to a maintenance work order in GCSS-Army.

Make sure your needed repair part is added to the component tab of that maintenance order.

Also, if you get stuck on another medical logistics question, don't forget to reference USAMMA's supply bulletins online at: <https://www.usamma.amedd.army.mil/Pages/Supply-Bulletins.aspx>

I'M LOOKING FORWARD TO JOINING THE GCSS-ARMY FAMILY!

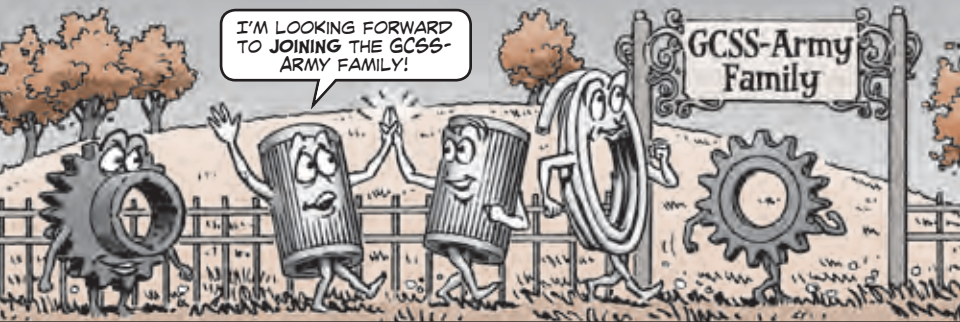

Inspections Help LLRCs Linger!

LONG LIFE REUSABLE CONTAINERS OR LLRCs **WON'T** LIVE UP TO THEIR NAMES WITHOUT INSPECTIONS TO CHECK FOR **DEFECTS** IN THE MOUNTING AND CLOSURE HARDWARE.

YOU GOTTA INSPECT EACH AND EVERY ONE OF US!

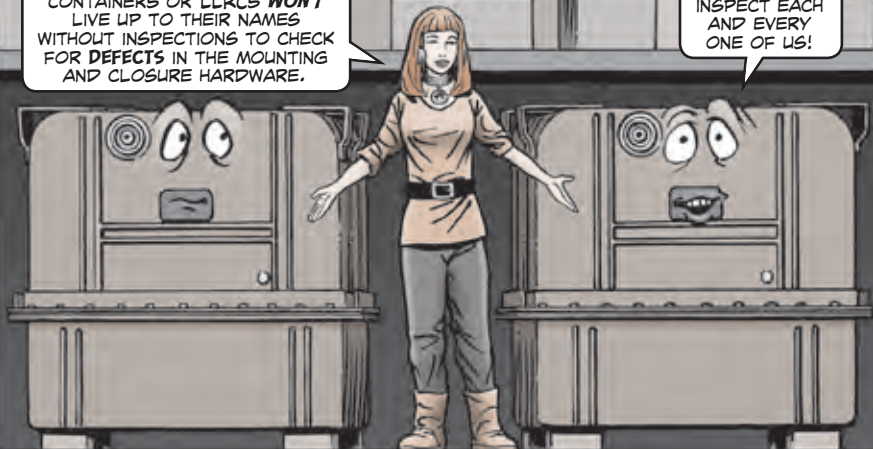

INSPECT EACH CONTAINER AND KEEP AN EYE OUT FOR STRUCTURAL DEFECTS THAT INCLUDE...



- cracks, holes or ruptures in the container or its lid.
- deformities in the container that prevent it from being closed or sealed properly.
- dents that interfere with the gaskets and any tape that may be used to seal the item.
- damage to the mounting/suspension system, including cracks, splits, tears, bond separation greater than $\frac{1}{32}$ of an inch and/or missing special hardware.
- a shock mount that is 12 years or older than the date printed on the mount.
- a container suffering from corrosion.



CONTAINERS WITH **ANY** OF THESE DEFECTS ARE CONSIDERED **UNSERVICABLE** AND HAVE TO BE **REPLACED OR REPAIRED** BEFORE THEY CAN BE USED.



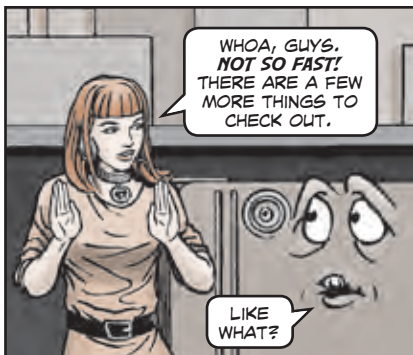
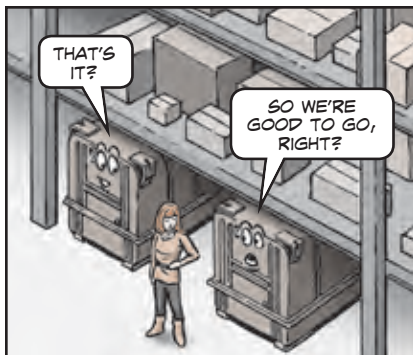

Look at the LLRC's name plates to make sure that they *aren't* missing or unreadable.

It's important to inspect the LLRC's skids, too. Skids should be wood packaging material (WPM) compliant. Defects reduce the skid's load bearing ability and without being compliant, they could get damaged during shipment.



Skids can suffer from decay, excessive splits and cracks or insect infestations. Talk to your WPM component managers if you have questions.

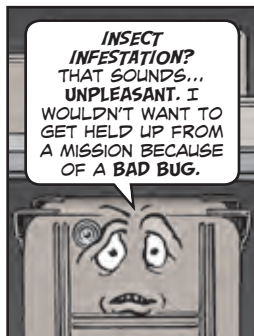

- Make sure to check your humidity indicators on a cyclical basis and to replace any humidity indicators that are completely white.
- Pay attention to the item type storage code and make sure that items that should be stored inside *are* stored inside.
- And last, but not least, check the record receptacle, desiccate holder, lifting rings, stacking guides, relief valves and view ports for any signs of **corrosion or damage**.
- Oh, and make sure there aren't any markings that are **missing, incorrect or unreadable**.

You can read more about LLRCs and get more packaging tips by downloading PSCC's *Packaging: The Basics* (Jan 18) from LOGSA's LIW website:

https://liw.logsa.army.mil/res/documents/Packaging_The_Basics_JAN_2018_sml.pdf

You'll need your CAC to access the document.



UIC Transfer Travel Plan

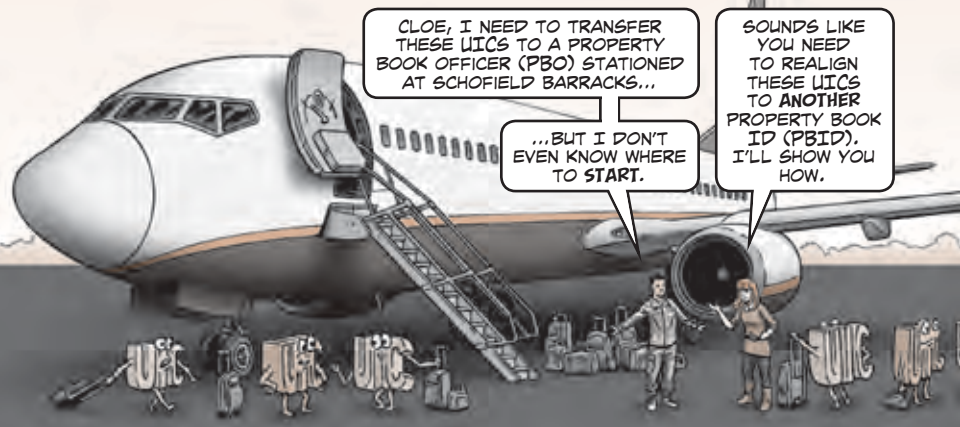

CLOE, I NEED TO TRANSFER THESE UICs TO A PROPERTY BOOK OFFICER (PBO) STATIONED AT SCHOFIELD BARRACKS...

...BUT I DON'T EVEN KNOW WHERE TO START.

SOUNDS LIKE YOU NEED TO REALIGN THESE UICs TO ANOTHER PROPERTY BOOK ID (PBID). I'LL SHOW YOU HOW.

1. Log into AESIP: <https://www.aesip.army.mil/irj/portal>
2. Click on the PBID tab, and expand the PBID Request applications tab under Detailed Navigation. Select PBID Maintain. Input the PBID to which the UICs are currently aligned and click Go.
3. Type the gaining organization's PBID in the "Gaining PBID" field next to the UIC to be realigned.
4. Provide a comment below detailing which UIC is realigning to which PBID.
5. Click Validate to make sure that everything is correct with the PBID and the gaining PBO will populate.
6. If the validation is successful, select Review Maintenance Request at the top of the page.
7. Click Submit and you'll receive a request number.
8. The request number will populate in the gaining PBO's Universal Worklist to accept. Notify the gaining PBO.

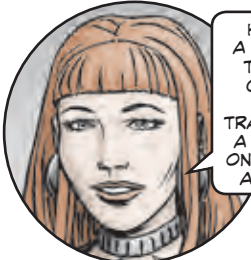

HERE ARE A FEW MORE THINGS TO CONSIDER WHEN TRANSFERRING A UIC FROM ONE PBID TO ANOTHER...

1. The losing and gaining PBOs should make sure the B290 relationship is correct in GCSS-Army and that the 803 structure is complete with realigned UICs.
2. Make sure the gaining PBO accepts realignment in their Universal Worklist. The transaction isn't complete until the realignment is accepted.



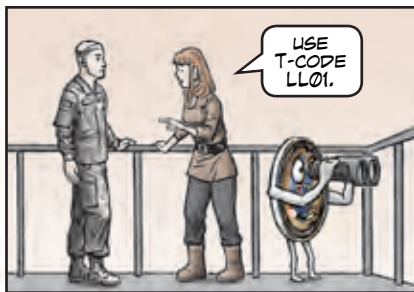
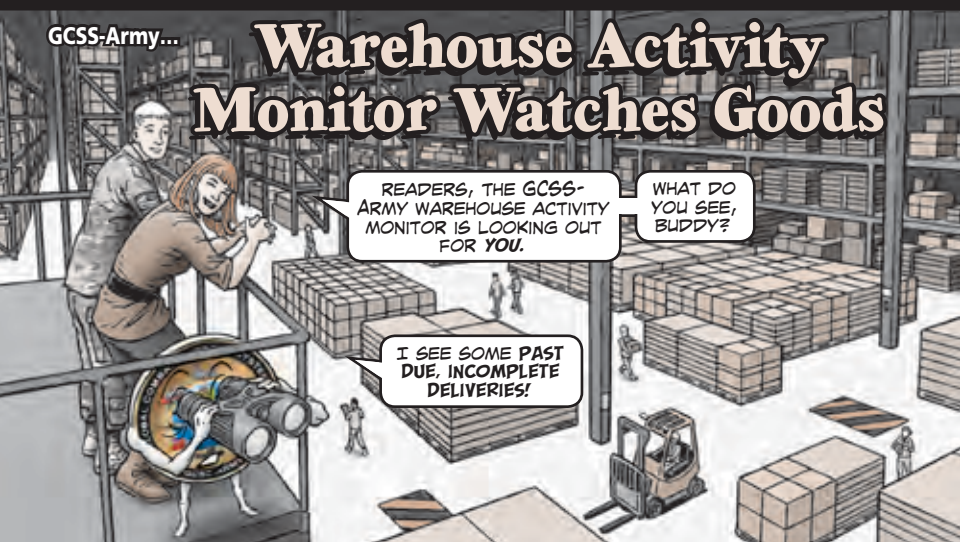

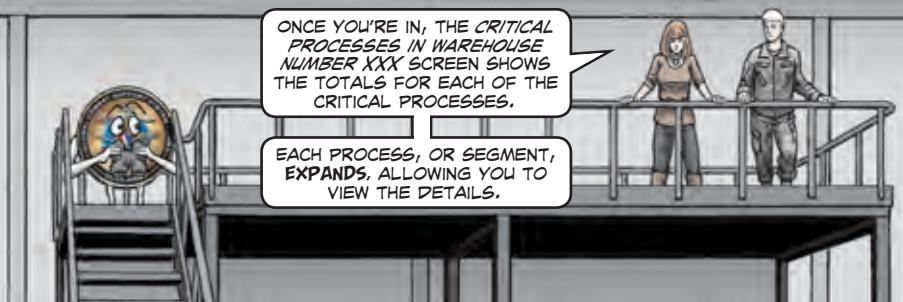

ONCE YOU'RE IN, THE **CRITICAL PROCESSES IN WAREHOUSE NUMBER XXX** SCREEN SHOWS THE TOTALS FOR EACH OF THE CRITICAL PROCESSES.

EACH PROCESS, OR SEGMENT, **EXPANDS**, ALLOWING YOU TO VIEW THE DETAILS.

SEGMENT INFORMATION INCLUDES:

XX Unconfirmed Transfer Orders (TOs)

This represents the number of pick and put-away transfer orders that are unconfirmed.

XX Open posting change notices

This is the number of posting changes made to a material's batch (condition code). The notices clear if you've confirmed the TO in the Unconfirmed Transfer Orders segment.

XX Critical Deliveries

The number of customer outbound deliveries that don't have a picking TO created. Picking TOs are documents that prepare material to move out of the warehouse. A picking TO doesn't create if the delivery due list available stock check finds a new material with no picking strategy or a bin that is blocked for physical inventory.

XX Interim storage stock, without movement

This segment lists the number of items with discrepancies posted to "999 Differences". This includes items in the 916 shipping area deliveries IST. These items have already moved to the issue section with the TO confirmed, but the item hasn't been post goods issued. There are also the 092 and 922 segments which disappear if you clear up corresponding issues in the Unconfirmed Transfer Orders segment.

THE WAREHOUSE ACTIVITY MONITOR **AUTOMATICALLY** UPDATES ONCE A DAY...

...BUT YOU CAN **MANUALLY** REFRESH IT BY CLICKING THE **MENU** BUTTON, HEADING TO EDIT AND THEN **DETERMINE DATA** AGAIN.



M870A1 Semi-trailer Hub & Drum Kit Missing Parts

Some of the M870A1 semi-trailer's hub and drum conversion kits, NSN 2530-01-643-7190, are missing three items:

- seal retainer, NSN 5330-01-255-0201; \$4/ea.
- tabbed washer, NSN 5310-01-049-9051; \$3.29/ea.
- grease cap, NSN 2530-01-520-5730, \$7.74/ea.

If your kit is missing these items, don't return it. Just order the missing parts, in quantities of two each per axle.

Unfortunately, units will have to pay for the missing parts until the current stock of kits is depleted. Then, the new kits will contain the missing components.

JGMTK Available

The Joint General Mechanics Tool Kit (JGMTK) is now available. Use the current GMTK, NSN 5180-01-548-7634, until stock is unserviceable. Then order the new JGMTK with NSN 5180-01-605-5146. The JGMTK meets Army and Marine Corps requirements with an upgraded case and additional tools. The new case is waterproof and meets increased impact resistance requirements.

M917A2 Dump Truck Tire and Wheel Assemblies

Can't find the complete tire and wheel assemblies for the M917A2? That's because the M917A2 doesn't currently have any assigned. But the correct info is provided in Figs 184 and 186 in TM 9-2320-302-24P (Feb 06, w/Ch 2, Aug 12) as follows:

M917A2 HET Tire Wheel Assembly	NSN
Front tire	2610-01-436-3332
Rear tire	2610-01-436-3334
Front wheel	2530-01-518-7626
Rear wheel	2530-01-518-6544
Front pneumatic tire valve	2640-01-522-2413
Rear pneumatic tire valve	2640-01-444-6175

GOT AVIATION SAFETY QUESTIONS?

The Utility Helicopter Safety Office is ready to help units with any issues affecting aircraft safety. Email your safety inquiries or issues to: usarmy.redstone.peo-avn.mbx-uh-po-safety@mail.mil

LRT-110 Crane Oil Sending Unit NSN

Get a new engine oil pressure sending unit for your 7 1/2-ton LRT-110 crane with NSN 6685-01-292-5205. It replaces NSN 6685-01-266-5848, which is shown as Item 47 in Fig 59 of TM 5-3810-305-24P (Sep 12). That NSN is a terminal item.

M9 ACE BATTERY SWITCHOUT

The M9 armored combat earthmover (ACE) is switching over from the old 6TMF-1 wet cell battery, NSN 6140-01-446-9498, to the 6TAGM (Hawker/Exide) battery, NSN 6140-01-485-1472. Make a note of this change until the new battery NSN is added to Item 7 of Fig 18 in TM 5-2350-262-24P (Jun 12).

Interrogator Sets TM Updated

TM 11-5895-1815-13&P (Feb 19) is the updated operator and field maintenance manual, including the repair parts and special tools list, for the AN/TPX-57(V)1, NSN 5895-01-530-4167, and AN/TPX-57(V)2, NSN 5895-01-590-4940, interrogator sets. It replaces TM 11-5895-1815-12&P (Jun 09).

TM distribution is restricted, so you'll need to log in with your CAC to:

<https://idmng.armyerp.army.mil/>

Choose the "ETM/IETM" app and search for the TM.

D6K Platform Wiring Harness NSN

Get a new platform wiring harness for your D6K dozer with NSN 6150-01-642-9874. It replaces NSN 6150-01-581-4090, which is shown as Item 15 in Fig 67 of TM 5-2410-240-24P (Jun 12). That NSN is no longer available.

M149A2 WATER BUFFALO HOSE ASSEMBLY

There's a new NSN for the M149A2 water buffalo trailer's hose assembly, shown as Item 7 in Fig 22 of TM 9-2330-267-13&P (Dec 15). Previous NSN 4720-01-440-9299 brought a 10-in hose assembly, but that's incorrect. The correct 13-in hose assembly comes with NSN 4720-00-851-8969.

ATLAS II Forklift Fuel Pump

A new high-pressure fuel pump for your ATLAS II forklift comes with NSN 2910-01-540-1530. It replaces NSN 2910-01-572-0995, which is shown as Item 7 in Fig 19 of TM 10-3930-677-23&P (IETM EM 0359, Aug 16).

PM Bridging Newsletter

PM Bridging's newsletter, *To Cross Is to Conquer*, has all the latest info on bridge erection boats, bridging system upgrades, testing, and revised TMs to cover operation, PMCS, maintenance procedures and parts changes. You'll find it at the UTAP website:

<https://utap.army.mil>

For logistical help with any bridging system, contact Marion Koreck at DSN 786-2239, (586) 282-2239 or email:

marion.j.koreck.civ@mail.mil

M969-Series Tanker Vapor Integrity Test Kit

The M969-series 5000-gallon fuel tankers need an annual vapor integrity test, as required by TM 9-2330-330-23P (Dec 15). But the TM doesn't list any equipment for the test in Table 2, "Tools and Test Equipment Requirements," which is where you'd expect to find it. Instead, you'll find the vapor integrity test set listed as Item 1 in Fig 84. Order it with NSN 2590-01-438-8806. Thanks to Jose Ruano of USAMSC-Korea for pointing out this fact!

Would You Stake Your Life ^{right now} on the Condition of Your Equipment?

DON'T SHIP US LIKE THIS!

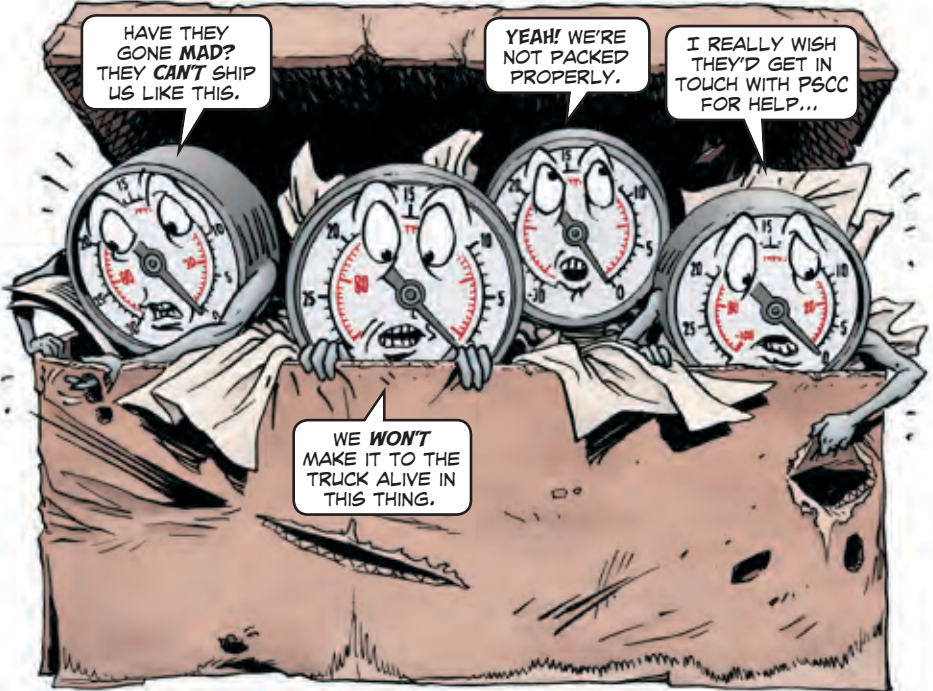

HAVE THEY
GONE MAD?
THEY **CAN'T** SHIP
US LIKE THIS.

YEAH! WE'RE
NOT PACKED
PROPERLY.

I REALLY WISH
THEY'D GET IN
TOUCH WITH PSCC
FOR HELP...

WE **WON'T**
MAKE IT TO THE
TRUCK ALIVE IN
THIS THING.

**Need shipping, packaging or
preservation advice?**

Call **PSCC** at:

DSN 795-5319 or (570) 615-5319

Or email:

usarmy.tyad.usamc.mbx.pt@mail.mil