

Issue 701

PS

April
2011

THE PREVENTIVE MAINTENANCE MONTHLY

TB 43-PS-701

Approved for
Public Release;
Distribution is
Unlimited

I-I'M NOT
SURE *WHAT*
TO DO.



(JOE
LUBER)

HMM...I
CAN'T QUITE
REMEMBER.

DOES THE
BRUSH GO IN
THROUGH THE
MUZZLE...OR...
THE CHAMBER?



GOOD GRIEF...
DON'T GUESS!
USE THE *TM!*

PM Questions About Your Rifle or Carbine?
See Page 27

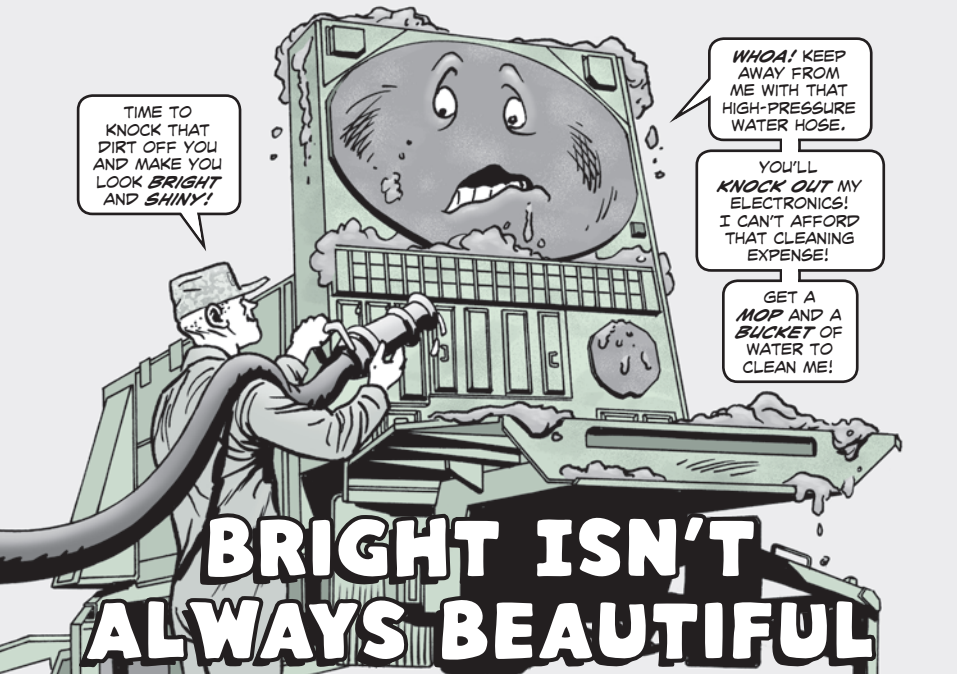

Soldiers and their commanders often want their equipment to look bright and shiny for inspections. To achieve that goal, they often employ high-pressure water or steam or take the equipment through wash racks.

That's usually not a bright idea. The cost of a bright, shiny appearance can be many thousands of dollars of ruined electronics equipment.

Most electrical components—like a SINCGARS radio or the MLRS's electronics unit—are built to be **water-resistant**. That means they can survive rain and humidity as long as their gaskets are in good shape. But these gaskets are definitely not designed to seal out high-pressure water. The water pushes past their seals and soon shorts and corrosion start doing their worst. An item like the Patriot's data link terminal module can cost many, many dollars to replace.

So is that bright, shiny appearance worth it? No. And when your commander gets the bill, he definitely won't think it's worth it.

As a general rule, don't use high-pressure water above wheel or track level on wheeled vehicles, tanks and trailers that have electronic gear. Check with the equipment's -10 TM to see if it's OK to run a truck or tracked vehicle through the wash rack. Sometimes it is OK, as long as you cover electronic components first. Never use any hose inside a vehicle or van.



PS**THE
PREVENTIVE
MAINTENANCE
MONTHLY**

TB 43-PS-701, The Preventive Maintenance Monthly, is an official publication of the Department of the Army, providing information for all soldiers assigned to combat and combat support units and all soldiers with unit maintenance and supply duties. All information published has been reviewed and approved by the agency responsible for the equipment, publication or policy discussed. Application of the information is optional with the user. Masculine pronouns may refer to both genders. The use of product or company names does not constitute endorsement of those products, services or companies by the U.S. Army.

ISSUE 701 APRIL 2011**COMBAT VEHICLES**

Stryker Differential Bolts
AVLB Bridge Retrieval
M1-Series Tank Gun Mount Exerciser
M88A1 Recovery Vehicle Roadwheel Pressure
M2/M3-Series Bradley Ammo Box Doors
M113-Series FOV Final Drives Oil Check
M113-Series FOV Ramp Reservoir Check
M109A6 Paladin Slip Ring Cleaning

**WHEELED VEHICLES**

Avoiding Dust and Sand Problems
Zipper Lubricant NSN
FMTV Cargo Cover Care
M939-Series Truck Dump Bed PM
HMMWV Air Filter Retaining Ring
Caiman Plus MRAP Intermediate Axle Leaks
M1070 HET Gas Particulate Filter Air Duct Hose
M1070P1 HET Seat Repair Parts

**SMALL ARMS**

Defeating Moisture in Small Arms Rooms
M240, M249 Machine Gun Scraper Tips
Small Arms Sights Use Lithium Batteries
M16 Rifle, M4/M4A1 Carbine Maintenance

**CBRN**

M17A3, A/E32U-8 Decon Filter Info
M17 Decons Need Exercise
M12A1 Decon Injector Pump Exercise
Free JSLIST for Training

2

**MISSILES**

2-3 Avenger Missile System Coolant Reservoir 26

**AVIATION**

6-7 HGU-56/P AH64 Apache Track Cleaning 35
7 UH-60A Avionics Water Protection 36-37
8 UH-60 Series Maintenance Reminder 37
9 UH-60s, Don't Step on Countermeasures 38
UH-60 Series Floor Removal Tip 39

**COMMUNICATIONS**

10-11 Battery Chargers Software Safety 40-41
12 SINGARS Vehicular Amplifier Adapter 42-43
13 Loop Clamp NSNs 43
14 Handling Excess Radio Assets 44
15 AN/TSC-156 Parts Shortage 45
16 Cable Corrosion Prevention 46-47
17

**SOLDIER SUPPORT**

18-19 Army Water Heater 400 48-49

**COMBAT ENGINEERING**

20-21 M4K Forklift PM 50-51
20-21
27-37

**LOGISTICS MANAGEMENT**

22
22-23 Records Reconciliation Tool Offered 52-53
24 New Online Language Training Program 54-55
25 Property Book Pointers, Part IV 56-58
25 AEPS Network Information 59

You are invited to send PS your ideas for improving maintenance procedures, questions on maintenance and supply problems and questions or comments on material published in PS.

Just write to:

MSG Half-Mast
PS, the Preventive Maintenance Monthly
USAMC LOGSA (AMXLS-AM)
5307 Sparkman Circle
Redstone Arsenal, AL 35898

Or email to:

logsa.psmag@conus.army.mil or
half.mast@us.army.mil

Internet address:

<https://www.logsa.army.mil/psmag/pshome.cfm>

By order of the Secretary of the Army:

GEORGE W. CASEY, JR.

General, United States Army Chief of Staff

Official:

Joyce E. Morrow

JOYCE E. MORROW

Administrative Assistant to the Secretary of the Army

1102503

PS, The Preventive Maintenance Monthly (ISSN 0475-2953) is published monthly by the Department of the Army, Redstone Arsenal, AL 35898-5000. Periodical postage is paid at the Huntsville, AL post office and at additional mailing offices.

Postmaster: Send address changes to PS, The Preventive Maintenance Monthly, USAMC LOGSA (AMXLS-AM), 5307 Sparkman Circle, Redstone Arsenal, AL 35898-5000.

Stryker...

BOLTS MAKE A DIFFERENTIAL DIFFERENCE

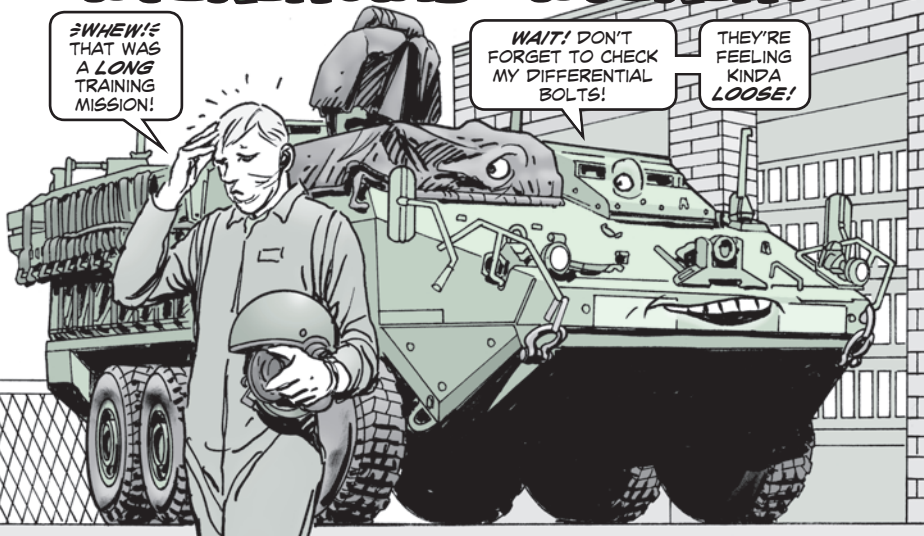

Checking the differential bolts on your Stryker is a before- and after-operation PMCS check, drivers.

And it's an important one. Heat, vibration, and collisions with brush, rocks and other debris can be a real bolt buster. And that's enough to make you lose a differential.

Each differential has eight bolts, nuts and washers holding it in place. Each vehicle has four differentials, so you have 32 sets of hardware to check.

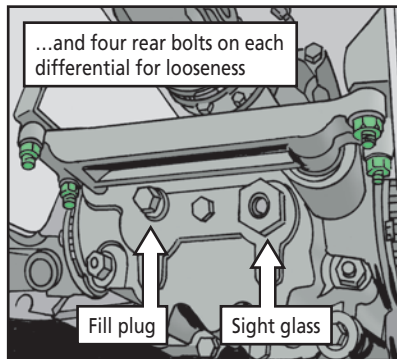
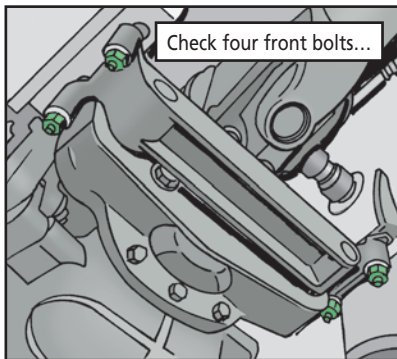

Look for shiny spots around the nuts and washers that indicate loosening bolts. If you see a shiny spot, report it.

Mechanics, add a few drops of sealing compound, NSN 8030-01-014-5869, to the bolt threads before torquing the nuts to 58-64 lb-ft. That'll help keep the nuts in place.

Replace missing bolts with NSN 5305-01-297-1865. A new nut comes with NSN 5310-01-155-3858 and a new washer with NSN 5310-01-265-6333.

While you're checking the bolts during after-operation PMCS, don't forget to take a quick look at the differential oil sight glass. The oil level should be 3/4 full in the sight glass.

If it's low, remove the fill plug and add gear oil, NSN 9150-01-363-1192, until it reaches the bottom lip of the fill port.

AVLB...

REMOVE IT OR LOSE IT!

When retrieving the bridge on your AVLB, you don't want *anything* in the way. 'Cause if it is, it's gonna get crushed!

Unfortunately, some drivers are forgetting to remove the AS-1729 whip antenna, NSN 5985-00-985-9024, before retrieving the bridge. That antenna has a lot of spring in it, but not enough to recover after being crushed by the bridge.

So remember to remove the antenna before recovering the bridge like it says in Step 31 on Page 0020-7 of TM 5-5420-202-10 (Dec 09). Then reinstall it after the bridge is in place.

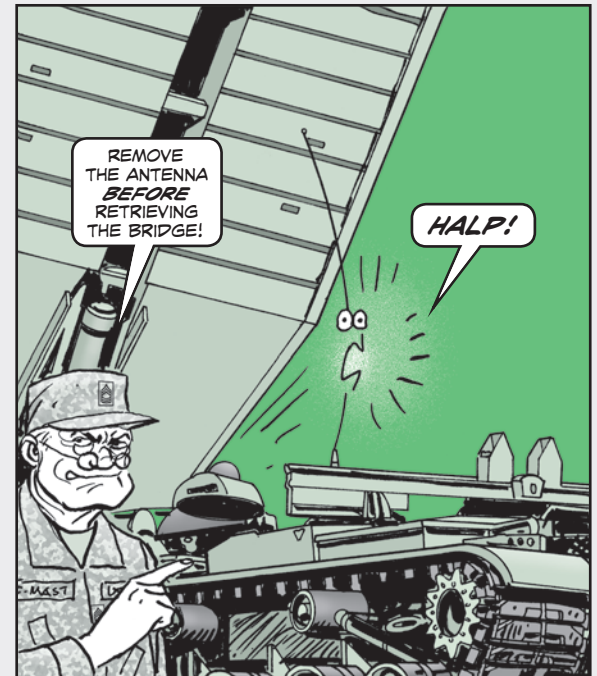

No Pain, No Gain?

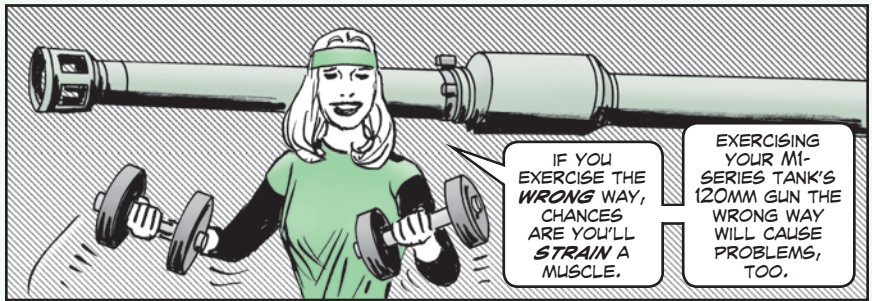
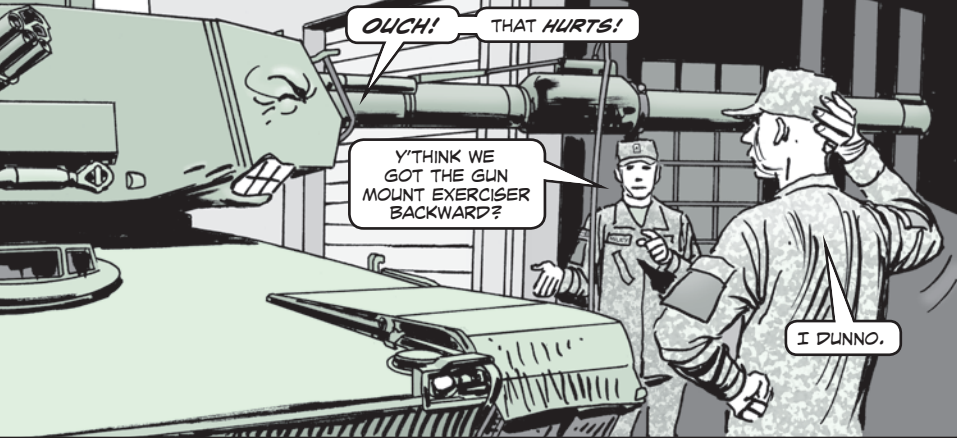

The gun mount exerciser (GME), NSN 4933-01-346-1791, was designed to exercise both 105mm and 120mm guns. So it can be a little confusing as to which way to position the GME when exercising the gun.

Get it wrong and the gun won't get the exercise it needs. Plus, the GME won't hold properly and you might damage the clamp.

To mount the GME properly, make sure the 120mm arrow is pointing **at the bore evacuator**. Then, exercise away!

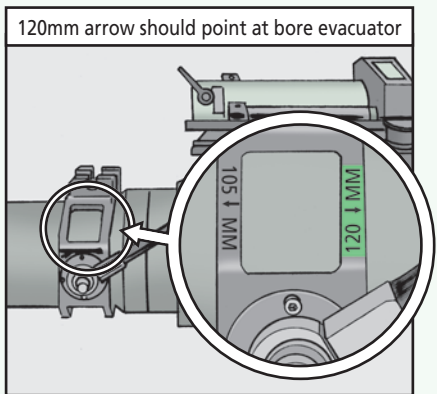

RELIEVE THE PRESSURE

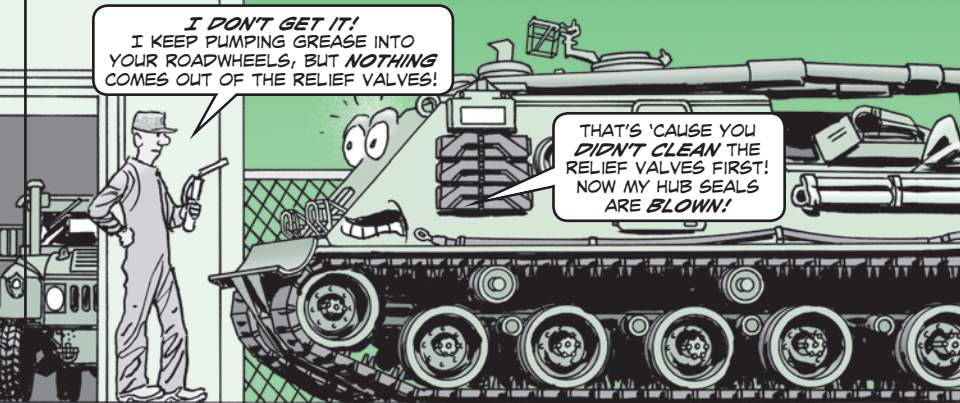

Most people don't work well under a lot of pressure. The same holds true for the roadwheels on your M88A1 recovery vehicle, crewmen.

A roadwheel relief valve that's clogged with dirt and sand won't relieve pressure when you pump in new grease. The pressure grows until something gives—usually the hub seal.

When the seal goes, so does the lube. The result is burned-out bearings.

So before adding new grease, use a cloth to wipe away any dirt and sand from the relief valve. Then pull out the valve stem.

If it slides out smoothly and pops back in when you release it, the valve's OK. If it doesn't, replace it with NSN 4820-01-070-7670.

Now that the roadwheel's ready for lubing, pay close attention to the first grease that appears from the relief valve. If the grease is gritty or watery, it could be that sand and water are getting in past the hub seal.

Stop and call your mechanic. New grease won't help until the bearings are disassembled, cleaned and repacked and a new seal is installed.

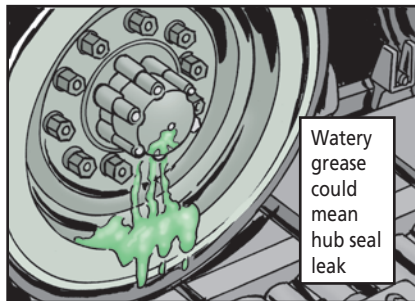
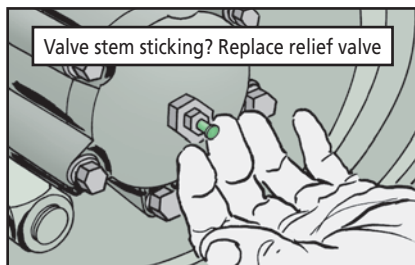

M2/M3-Series Bradley...

Close Those Ammo Box Doors!

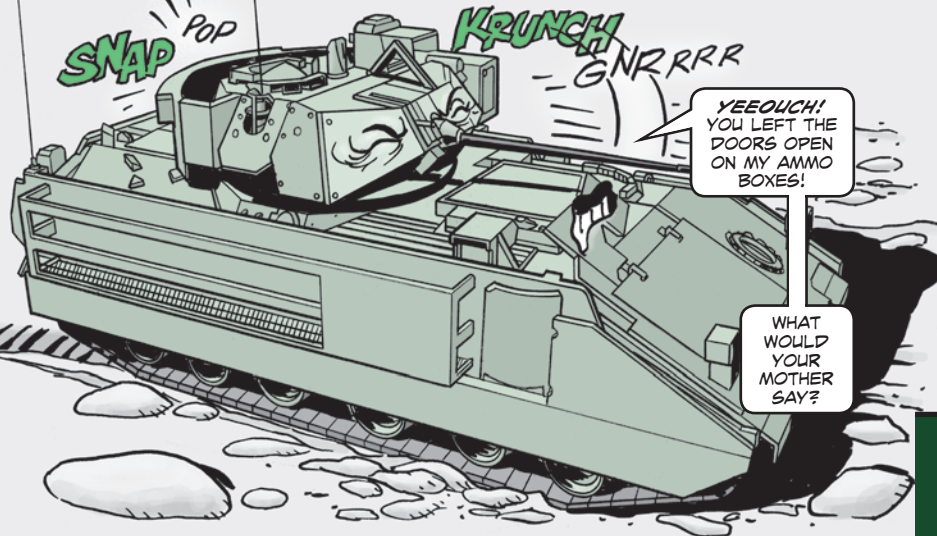

Years ago, when you ran into the house after playing with your friends, you could always count on Mom's friendly reminder: "Shut that door! You don't live in a barn!"

Now that you're all grown up and operating a million-dollar Bradley, Mom's reminder still holds true. It's up to you to properly shut the doors on the AP and HE ammo boxes.

The ammo box doors have a simple swing latch that holds them in place. But if you get in a hurry, the latch won't catch. The door falls forward and catches on cables and connectors as the turret traverses.

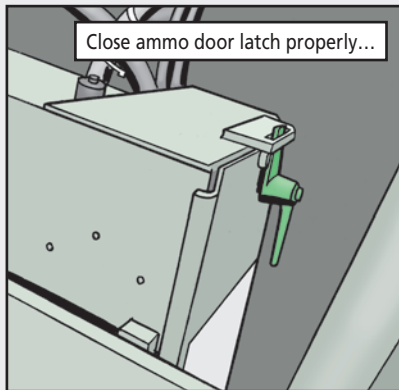

Close ammo door latch properly...

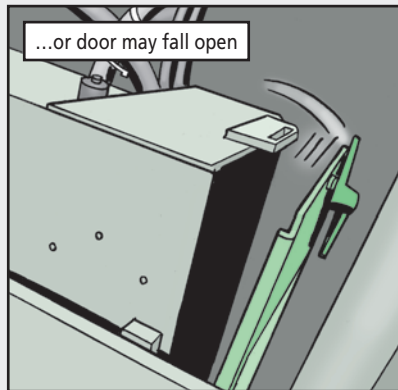

...or door may fall open

One unit had a fallen door rip open the fuel hose that interconnects the upper and lower fuel cells. That put 75 gallons of fuel in the hull!

So after closing the ammo doors, take an extra second to make sure they're secure. Mom would be so proud!

Spring Could Be the Thing

After the ammo doors have been opened and closed day after day, you might notice the latch handle getting a little loose. That's because the torsion spring, NSN 5360-01-183-2971, inside the latch handle assembly is wearing out.

When that happens, the doors could vibrate open, even if you're careful about closing them. If the latch handle starts feeling loose, tell your mechanic. He'll replace the spring, which will keep the door closed nice and tight.

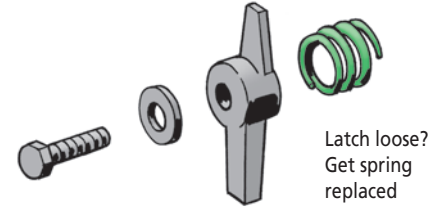

M113-Series FOV...

DON'T FORGET THE FINAL DRIVES

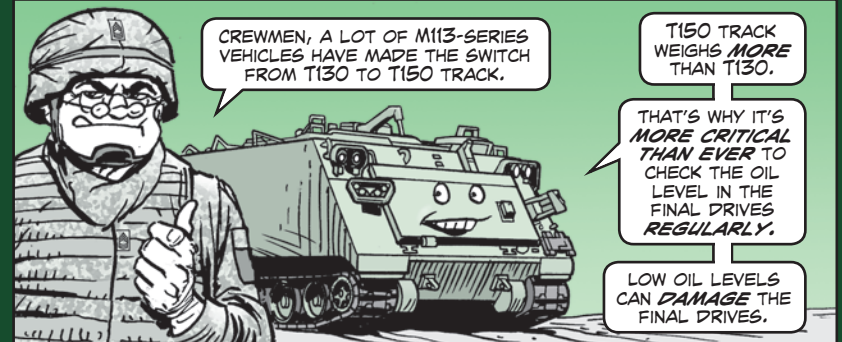

JUST CHECK THE GAGE RODS FOR BOTH FINAL DRIVES WEEKLY.



Two Steps for Ramp Reservoir



Checking the ramp hydraulic reservoir level is a daily task, drivers. It seems simple enough, too. Just make sure the fluid level is halfway in the sight glass, right?

Not so fast. There are two more steps involved to check the reservoir level the right way.

STEP 1: Your vehicle must be parked on level ground. If the vehicle is on an incline, the sight glass reading may make it appear that there is too much or too little hydraulic fluid in the reservoir.

If you adjust the level based on a faulty reading, you could end up with too much or too little hydraulic fluid. Too much means a big messy problem with FRH leaking out of the hydraulic system tank breather. Too little results in a ramp that moves erratically or not at all.

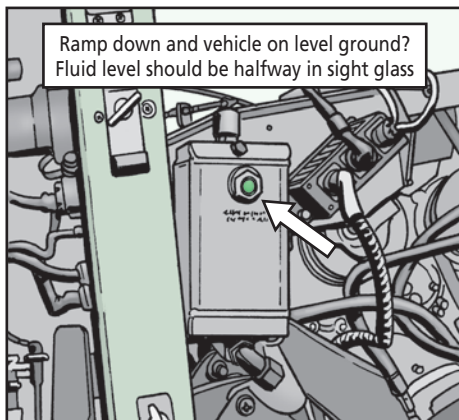

STEP 2: The ramp must be all the way down. If you read the reservoir sight glass while the ramp is closed or partially open, the reservoir will appear to have too little hydraulic fluid.

You'll find these two steps on Card 17 of LO 9-2350-277-12 (Jul 94, w/Ch 1, Feb 97).

CLEAN SLIP RING IN SEGMENTS

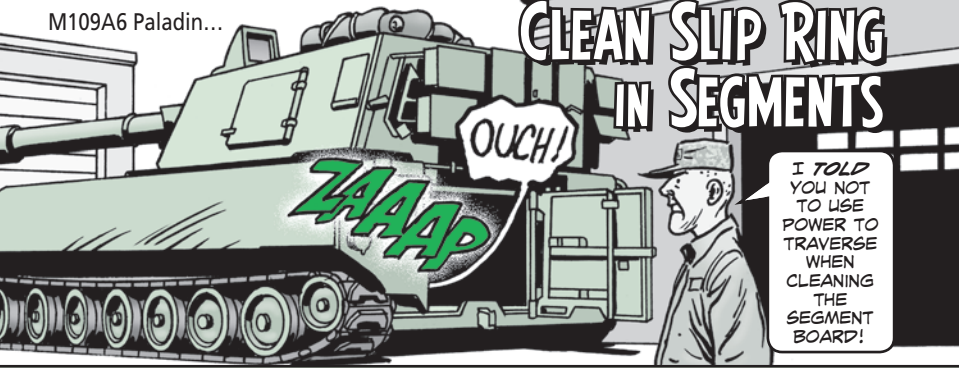

Dirt, sand, oil, and condensation have a habit of collecting on your Paladin's slip ring, crewmen. As the turret is traversed, that crud builds up on the segment board and shorts it out. Things go downhill from there. A shorted segment board shuts down your commo and the vehicle motion sensor. You'll also get navigation faults in the automatic fire control system.



1. Remove the cover plates over the segment board.

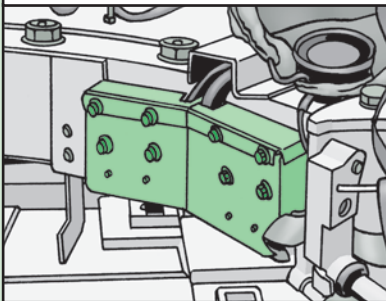

2. Soak a nylon scrub pad, NSN 7920-00-753-5242, with denatured alcohol and clean the exposed portion of the board.



3. Wipe the scrubbed area of the board again with a clean cloth

4. Manually traverse the turret enough to expose the next portion of the segment board and clean again. Keep manually traversing until the entire board is clean. Watch out, though! Using power to traverse the turret will give anyone cleaning the segment board a big *shock!*

AVOIDING DUST'S MAINTENANCE MESS

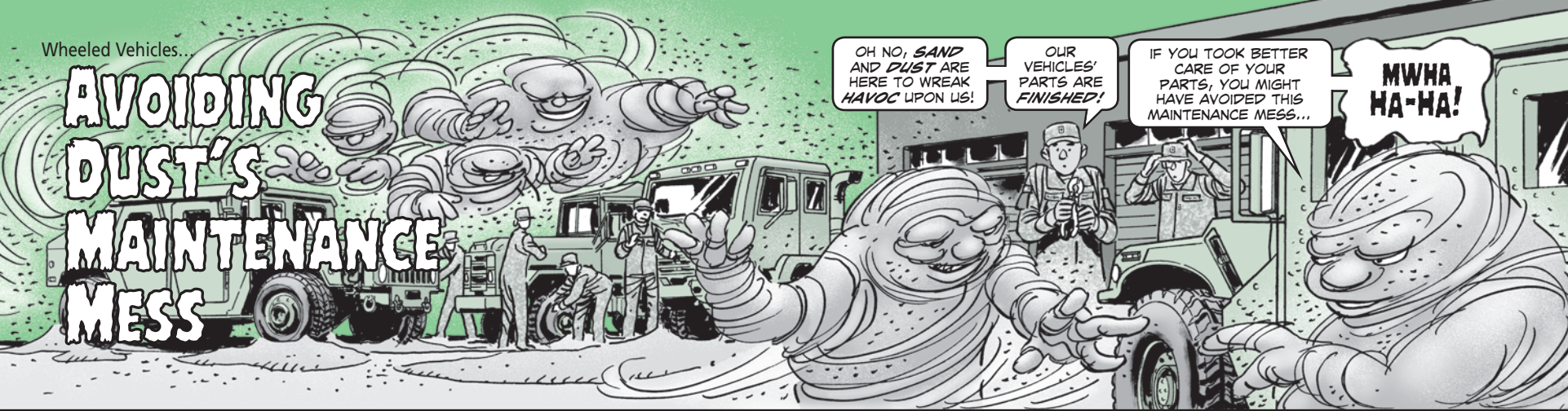

Grease and oil attract dust and sand like magnets attract metal! The resulting mixture of grease, oil, sand and dust leaves you with a gritty maintenance mess. And that mess can damage metal surfaces and rubber seals.

SMART MECHANICS TRY TO AVOID THIS MESS!

THEY CAN'T SHUT OUT SAND AND DUST COMPLETELY, BUT THEY CAN DO THE FOLLOWING TO TAKE BETTER CARE OF THEIR VEHICLES...



- Keep sand and dust off parts while making repairs by wrapping greased parts with waxed paper or newspaper

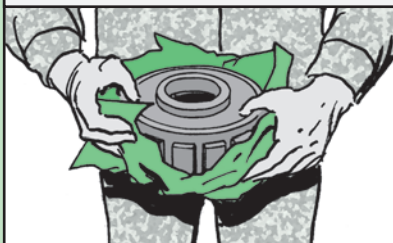

- Keep the lids on grease cans.



- Use plastic wrap to keep dust and sand out of open components. NSN 8135-00-043-5331 gets an 11½-in by 100-ft roll of self-clinging plastic film.

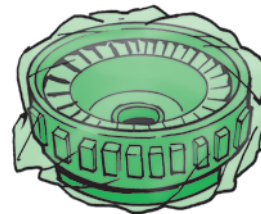

- Use plastic bags to hold bearings and small parts like nuts and bolts that might get lost or dirty before you need them again. Also, tag the bags to make sure everything goes back where it came from.

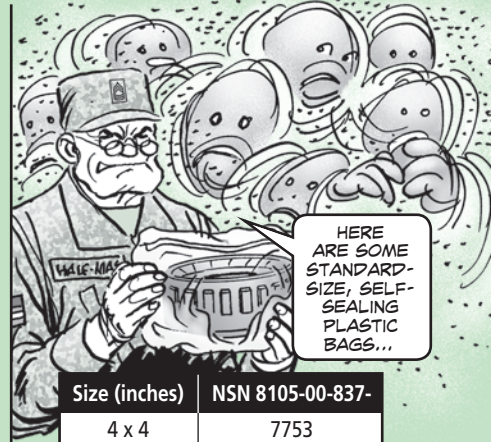

Size (inches)	NSN 8105-00-837-
4 x 4	7753
6 x 6	7754
8 x 8	7755
11 x 10 1/2	7756
12 x 12	7757

Zipper Lubricant

Sand and grit in a zipper can cause it to stick, but it doesn't have to stay that way. Just clean off the zipper with a toothbrush and apply zipper lubricant, NSN 9150-00-999-7548. Rub the lubricant on each side of the track and slide the zipper up and down a few times to get it working smoothly.

TAKING CARE OF YOUR COVER



Getting things wet that you meant to keep dry can be a problem if your FMTV's cargo cover is ripped. Avoid this by doing one smart action: PMCS!

Check for holes and tears in your truck's cargo cover **before** moving out on a mission. Then plug up any that you see. Patch them with repair kit, NSN 2540-01-496-4442. That should solve your problem while keeping cargo dry and you comfortable.

Cargo Cover Repair

The repair kit mends **vinyl-coated** cargo covers. Don't use it on canvas because it wasn't made for that. The kit comes with an instruction card, alcohol pads for cleaning the vinyl, scissors and a roll of repair tape.

Here's how to use it:

- Make sure your cargo cover is dry and is placed in an area that is 50°F or higher.
- Find the hole or tear on the inside (or underside) of the fabric. Make all repairs on this side.
- Brush off loose soil or dirt from the area to be taped. Clean the area with an alcohol pad. Wipe a large enough surface so that the tape will fit well inside the cleaned area.
- Let the fabric dry.
- Spread the fabric on a flat surface.
- Cut the tape two inches longer than the hole you want to cover.
- Using the scissors, round off the four corners of the tape. Rounded corners make the tape less likely to peel off.
- Peel off the film liner from the tape as you apply it to the inside of the fabric.
- Press the tape firmly against the fabric. Allow the tape to set, the longer the better. Overnight is best, but give it at least 20 minutes.



Seam Repair

If rain gets in after you've repaired your truck's canvas cover, you may need to seal the seams. Apply sealant to the seams using a small brush. A pint of sealant comes with NSN 8040-00-262-9028; NSN 8040-00-281-1972 brings you a gallon.

M939-Series Trucks...

THE WAY TO KEEP YOUR M929- AND M930-SERIES DUMP TRUCKS ON THE JOB IS TO LOAD UP ON PM.

HERE ARE A FEW POINTERS TO KEEP IN MIND...

DUMP BED BASICS

Keep the Bed Dry

Standing water in the dump bed means the drain holes are clogged. Ignore the standing water long enough and you'll have a rusted bed.

Eyeball the bed corner drain holes for debris. If you find plugged holes, turn the tip of a screwdriver through the holes to open them up.

If your dump truck is going to sit for a while (like weeks or months), keep the bed elevated so water can easily drain. Use the dump body support braces (bedlocks) to hold the bed up and keep pressure off the main hydraulic cylinders.

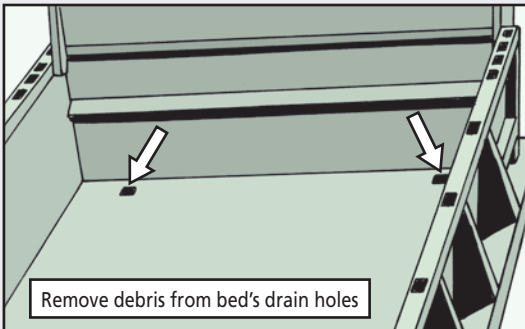

Remove debris from bed's drain holes

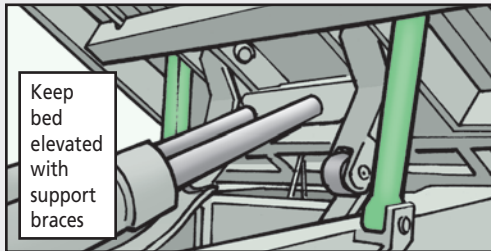

Keep bed elevated with support braces

Keep 'em Lubed

With the dump bed up, lube the grease fittings for the bed rollers during scheduled services. Lube keeps the rollers moving smoothly when the bed is elevated. Also, put a **thin** layer of grease on the roller tracks for smooth operation. If you use too much grease it'll just get squished out and wasted the first time the rollers move across the track.

Get the Hook

Lube both grease fittings on the safety latch hook during scheduled services. Without lube, the hook can freeze in place. Then it—or the latch mount—will break when you raise the bed.

HMMWV...

KEEP RETAINING RING IN PLACE

MY AIR FILTER
CANISTER'S
RETAINING RING IS
LOOSE!

COUGH
COUGH!

COUGH
COUGH!

ALL THIS SAND IS
GOING STRAIGHT
INTO MY
AIR FILTER!

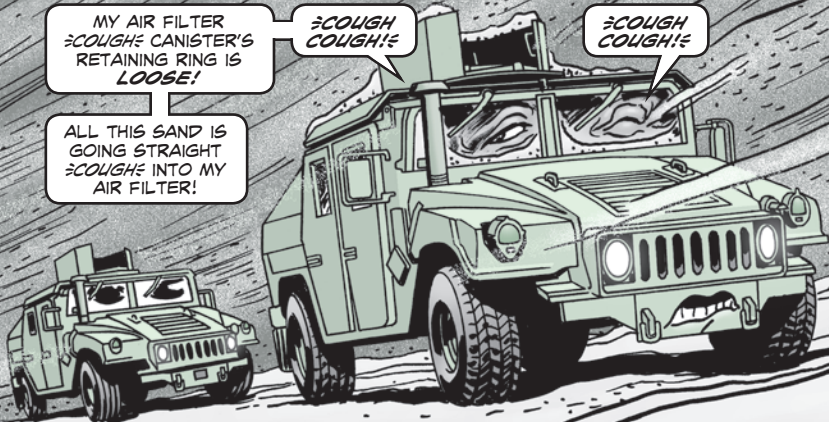

Operators, the air filter canister on your HMMWV takes a lot of knocks and bangs from rocks thrown up by the front tire.

The retaining ring that holds the canister end in place is especially prone to damage. The metal that protects the ring's retaining mechanism is thin and bends easily.

If the metal bends outward, it can't hold the mechanism's square nut in place. The retaining ring loosens, letting in dirt and sand. Before you know it, the filter is completely clogged and the engine overheats.

Take a quick look at the retaining ring before operation. If the ring is loose, tighten it. Then use pliers to squeeze the metal tight around the retaining mechanism's square nut. That'll help keep the retaining ring from loosening again.

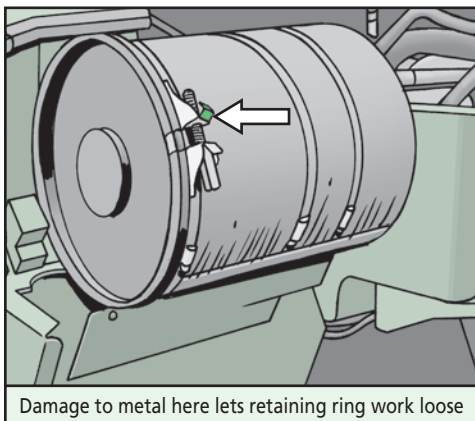

SNEAKY AXLE LEAKS

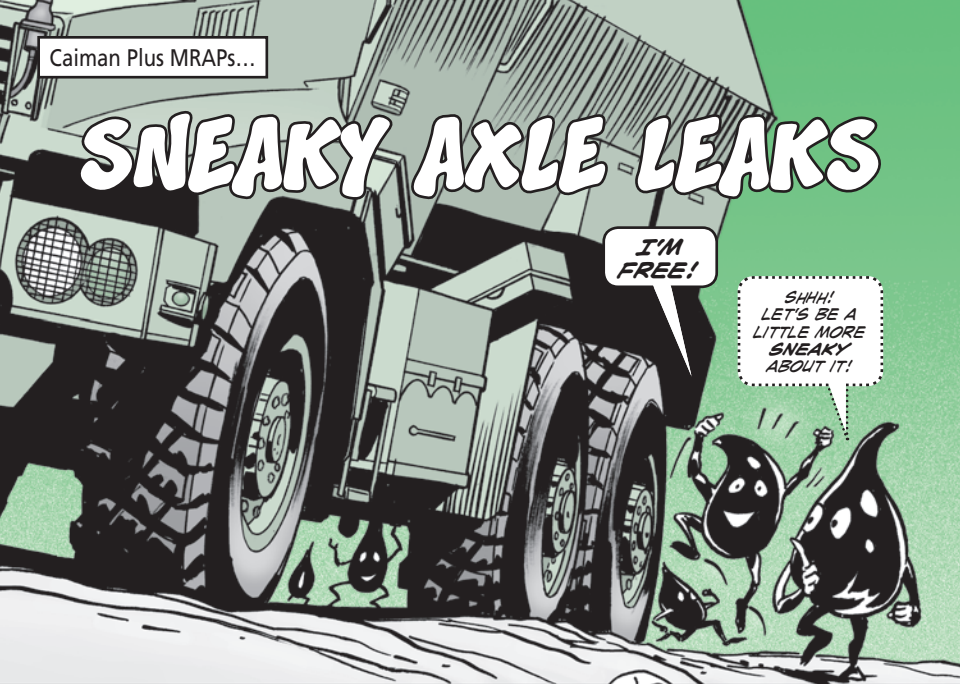

THE INTERMEDIATE AXLE ON CAIMAN PLUS MRAPs ARE KNOWN TO LEAK... AND LEAK... AND LEAK!

THAT'S BECAUSE THE DIFFERENTIAL'S CARRIER BOLTS COME LOOSE, OFTEN ON A WEEKLY BASIS.



That means you have to get down on your hands and knees and eyeball the differential at least weekly. Look for oil leaks coming from around the bolts and for any drips on the ground directly below. Enough of an oil leak will cause the differential to burn out. No differential, no mission!

So check for loose bolts by using a wrench to give 'em a tug. Find a loose bolt or an oil leak? Report it.

Your mechanic can remove the bolt and add a dab of sealing compound, NSN 8030-01-158-6070, to its threads and re-torque it to 74-96 lb-ft. By the way, this info will be added to the PMCS in TM 9-2355-319-23.

Torque these bolts to 74-96 lb-ft

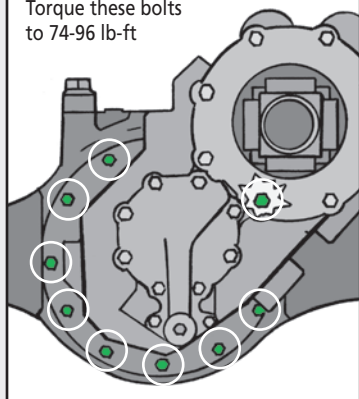

M1070
HET...

WE'VE GOT TO
REPLACE THOSE
GPFU HOSES AGAIN!

THAT'LL COST US
A LOT OF MONEY,
MR. KERSHNER!

NOT THIS TIME!
YOU CAN ORDER
JUST THE HOSE
INSTEAD OF THE
WHOLE HOSE
ASSEMBLY!

SAVE SOME MONEY ON AIR DUCT HOSE!

Dear Editor,

With budget constraints facing everyone, it pays to save money wherever and whenever you can. A good place to start is the air duct hose, NSN 4720-00-004-8249, for the M1070 HET's gas particulate filter unit. It costs \$206.22.

With a little research, we found that the exact same hose is used for the M9 ACE's air purifier. It's listed as Item 19 in Fig 172 of TM 5-2350-262-24P (May 09). The difference is that the ACE manual breaks the hose down into its three individual components, listing them as Items 20-22.

The hose, NSN 4720-00-829-2761, costs \$65.03. The clamp, NSN 4730-00-269-3760, is available for \$1.13. The coupling half, NSN 4730-00-935-1643, is \$48.40. If you do the math, all three parts add up to \$114.56, a savings of \$91.66!

And it gets better. The problem we usually see is that the hose gets torn or dry-rots. By reusing the coupling half and clamp and replacing only the hose, we save \$141.19 per replacement.

Could you pass on these great cost savings to the field?

C.J. Kershner
DOL Maintenance
Ft Riley, KS

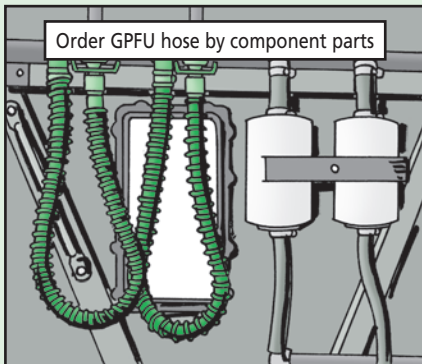

Editor's note: You bet, C.J.! Mechanics, the hose is listed as Item 16 in Fig 250 of TM 9-2320-360-24P (Feb 98). Make a note of these NSNs until they can be added to the TM.

How Do I Fix the Seat?

DID YOU FIND THE REPAIR PARTS FOR THE SEAT IN MY M1070P1 HET?

YEP! PROBLEM IS, THEY'RE IN THAT HAYSTACK THERE!



TRYING TO FIND REPAIR PARTS FOR THE M1070P1 HET'S NEW SEAT AND SEAT BELT SYSTEM CAN BE LIKE LOOKING FOR A NEEDLE IN A HAYSTACK.



THE PARTS ARE *SOMEWHERE*, BUT, MAN, IS IT EVER HARD TO FIND 'EM!

BUT NOW WE'VE GOT *GOOD NEWS!*



Now there is a ballistic seat kit avail-able with the parts you need! The kit comes with NSN 2540-01-570-8602.

Unfortunately, this new kit had to be rushed into the supply system. That means it will take some time before all the individual parts are provisioned so they can be ordered separately.

The manufacturer, Global Seating Systems, has a parts manual for the seat. Some of its part numbers cross to NSNs. For a copy of the manual, with NSNs added, send an email to Half-Mast:

half.mast@us.army.mil

Repair parts for new HET seat are available in kit!



Small Arms...



DRY UP MOISTURE THREAT!

Moisture is the silent enemy of your rifles, pistols and machine guns. While you think your weapon is safely tucked away in the arms room or in a transport ship or plane, moisture can feed the corrosion that eats away at the weapon's metal. When you get ready for action again, you may find that the barrel or bolt has been ruined.

But there are several ways you can dry up the moisture threat.

Prepare for travel. If your weapon is traveling from SWA back to your home base, it may be going from extreme heat and low humidity to either a plane where the temperature will be cold or to a ship that will go through lots of salty sea air. And, if the weapon's final destination is someplace like Ft Polk or Stewart, it will face very high humidity there.

To protect your weapon against all the moisture produced by temperature changes and humidity, you at least need to clean and thoroughly lube it like the -10 TM prescribes. The best protection for travel, though, is to also use vapor corrosion inhibitor wrap, NSN 8135-00-664-0015.

PS had an article in PS 660 (Nov 07) on the best ways to prepare weapons for shipment. Access it at:

<https://www.logsa.army.mil/psmag/archives/PS2007/660/660-18-20.pdf>

If you don't prepare your weapon for overseas travel, count on its being ruined by corrosion by the time it arrives. Some posts report receiving weapons back from SWA with absolutely no lube and thus defenseless against moisture.



Fight humidity in the arms room. Places like Stewart or Polk are very humid and many other Army posts have to deal with some humidity. The very best way to fight humidity is with a dehumidifier that has a 15-pint capacity.

But for larger arms rooms or very humid environments, you probably need a dehumidifier that has a 30- to 60-pint capacity. Most large home supply outlets have a large selection of dehumidifiers.

Dehumidifiers lose their effectiveness above 95°F, so arms rooms should be kept below that temperature if possible. Always position a dehumidifier on the floor, since that's where moisture settles. Air circulation fights humidity, so running a fan in the arms room is a good idea, too.

A dehumidifier won't do much good if you don't empty it. In very humid environments, you may need to do that every day. And if you're going to be gone for several days, you need to make sure someone else empties it.

Prepare for storage. Armorers should not accept any weapon for storage in the arms room that hasn't been cleaned and lubed.

Don't leave barrel caps on rifles. They trap moisture in the barrel.

Weapon TMs say you can store weapons for up to 90 days without cleaning or lubing them. But you still need to check all the weapons in arms room for signs of corrosion at least monthly, especially in humid areas. If you wait three months to check, it could be too late.

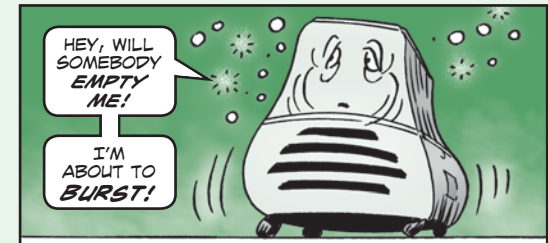
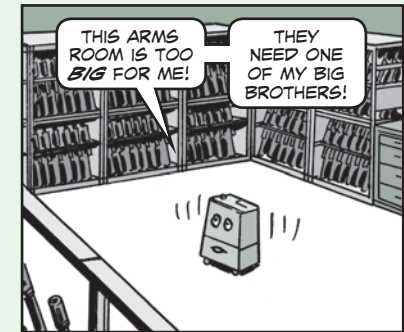
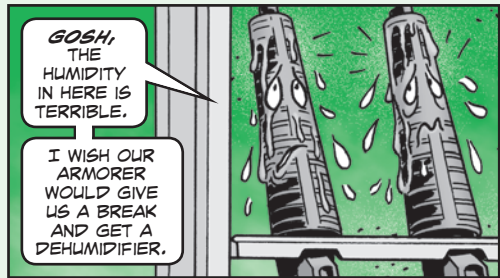

No Scraper Leaves You in a Scrape!

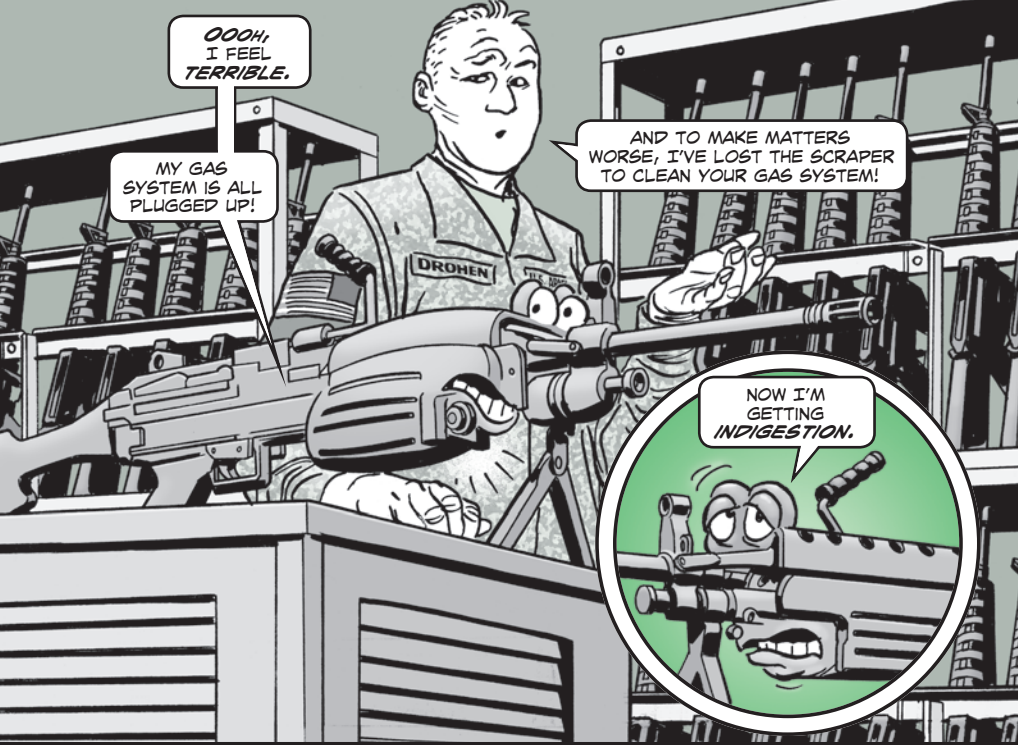

Dear Editor,

In my work as a TACOM logistics assistance representative at Ft Campbell, I visit many arms rooms. I often find the arms rooms don't have enough scrapers for their M240 and M249 machine guns. That will leave gunners in a real scrape.

Without the scraper, you can't clean the carbon out of either machine gun's gas system. The carbon plugs the gas system and eventually the machine gun stops firing. And it won't fire again until that gas system is cleaned, which you can't do because you don't have a scraper.

So when a scraper goes missing, immediately tell your armorer. He can order the M240 scraper with NSN 4933-01-033-1504 and the M249's with NSN 1005-01-131-1914.

Andrew Guilliams
TACOM LAR
Ft Campbell, TX

Editor's note: Excellent advice, Andrew—now a few tips on using the scraper:

Use it as soon as possible after firing. The longer carbon sits, the harder it is to scrape off.

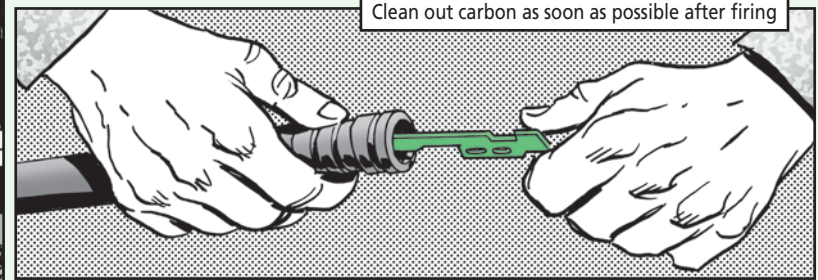

Don't use CLP in the gas system. CLP cleans off carbon, but it also collects carbon during firing. Clean the gas system with the scraper only—no CLP.

If you can't get off all the carbon with the scraper, tell your armorer. He can use dry cleaning solvent to dissolve the carbon.

Small Arms... THERMAL SIGHTS *NEED* LITHIUM

HIT THE ROAD, YOU WEAK SISTERS!

I USE ONLY LITHIUM!

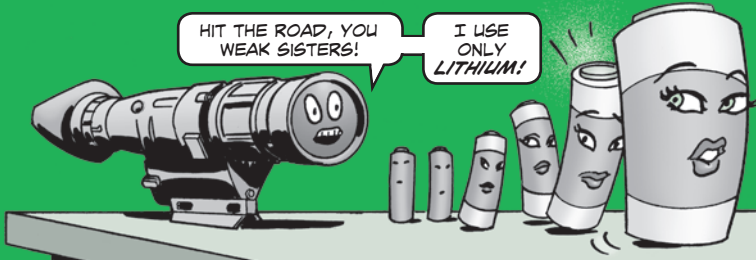

Economizing is great, except when it hurts your mission. And your mission will suffer if you try to save money by using cheap batteries in your thermal weapon sights.

Alkaline batteries are cheap and do great in stuff like your TV remote control. But you don't want to use them in the sights for your weapons. Lithium batteries can last up to 10 times longer than those cheap alkalines. That difference can be life-saving during a long mission. And because lithium batteries last so much longer, you don't need to carry lots of spares.



ORDER LITHIUM AA BATTERIES WITH NSN 6135-01-333-6101.

Super Filters Stop Sand

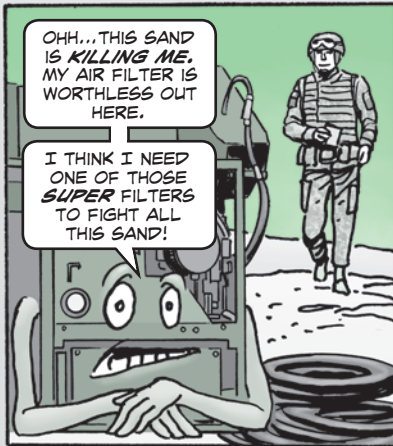
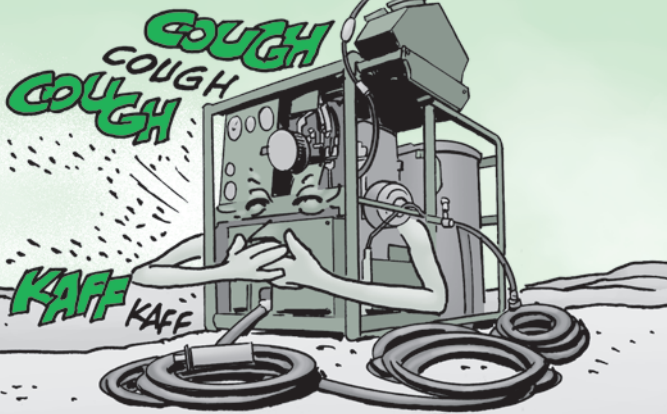

SAND CAN BRING YOUR M17A3 AND A/E32U-8 DECONS TO A DEAD STOP.

IT GETS INSIDE THE ENGINE AND CAUSES MOVING PARTS TO STOP MOVING.

THE STANDARD DECON FILTERS DO A FINE JOB IN NORMAL CONDITIONS, BUT TO SEAL OUT SAND IN THE DESERT YOU NEED THE SUPER FILTERS AND THE WATER ASSEMBLY CAPS.



IF YOU'RE OPERATING IN THE DESERT OR ARE SCHEDULED TO GO THERE, ORDER THE FOLLOWING FILTERS AND CAPS. THERE IS NO OUTLET CAP FOR THE A/E32U-8.

M17A3

- Air filter, NSN 2940-01-529-8953
- Inlet cap, NSN 4730-00-485-5055
- Outlet cap, NSN 4730-00-929-0791

A/E32U-8

- Air filter, NSN 2940-01-529-8953
- Inlet cap, NSN 4730-00-484-5055

To clean both filters, tap the filter element with your hand to knock dirt loose. Gently brush out the dirt with the soft bristle brush in your tool kit. Never use gas, caustic solvents, strong detergents, high-pressure water, or steam on the element. They damage the filter.

Instead, spray K&N air filter cleaner, which is part of the cleaning kit, NSN 2945-01-512-0412, on the entire filter element and let it soak in for 10 minutes.

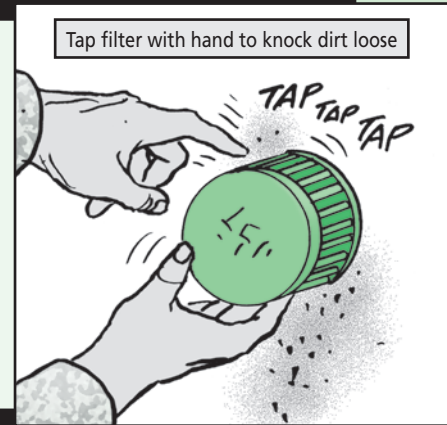

Then rinse the filter from the inside out with low-pressure water. Shake off excess water and let the filter air dry. Never use compressed air, an open flame or a dryer. They damage the filter.

When the filter is dry, re-oil it with K&N air filter oil, which is also part of the cleaning kit. Put one pass of oil along the bottom and top of each of the filter's pleats. Let the oil soak into the filter for 20 minutes. Apply more oil to any filter areas that are still white. Never use any other oils on the filter except in emergencies.

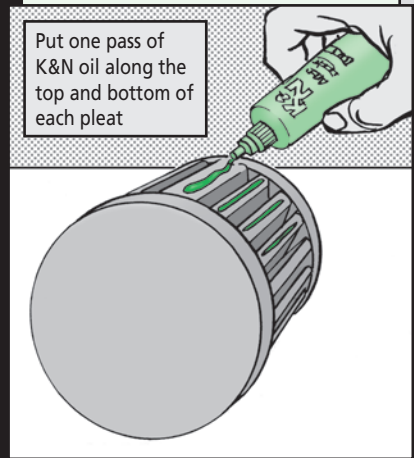
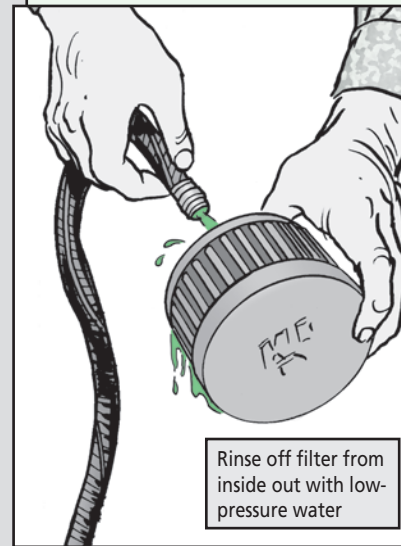

DON'T REST M17 TO DEATH

IF I COULD JUST GET A LITTLE WEEKLY EXERCISE, I COULD DECON LIKE YOU WOULDN'T BELIEVE! BUT THIS SITTING IS JUST *KILLING ME!*

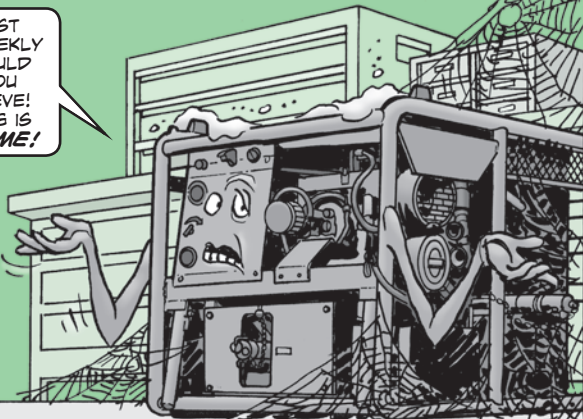

IN MOST CHEMICAL COMPANIES, THE M17-SERIES DECONS SIT AND SIT AND SIT.

UNFORTUNATELY, YOU CAN REST AN M17 TO DEATH.

HERE'S WHAT CAN HAPPEN WHEN AN M17 ISN'T RUN REGULARLY...



- Engine parts gum up and can't function when you try to start your M17.
- The gaskets, seals, and hoses begin to dry-rot.
- The pull cord dry-rots from being left reeled up for weeks. Next time you yank on it, SNAP.
- Calcium collects in the pump and plugs it up.

Any of these problems will put your M17 down and require the hassle of ordering new hoses or a pull cord or replacing seals.

That hassle disappears if you just take time during your weekly PMCS to operate the M17 for 15 minutes or so, including hooking up the hoses and running water through them. You've just eliminated many M17 problems.

Here are a few more tips to help your M17 do its job:

If you're going to operate the burner on JP8 or diesel fuel, first run the burner on MOGAS for five minutes. That heats the burner up and helps it fire up on the less combustible JP8 and diesel.

TM 3-4230-228-10 says to turn the burner fuel knob all the way clockwise when you start the burner. Actually, it's often better to turn the knob only 3/4 of a turn clockwise.

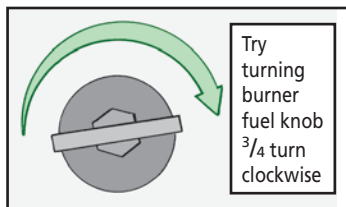

Exercise Your Pump

MAKE SURE I GET SOME EXERCISE TO KEEP MY FUEL INJECTOR PUMP **PUMPED UP** OR I'LL BE LIKE THIS DECON...

...ONE WITH A **DEFUNCT** FUEL INJECTOR PUMP!

UGH!

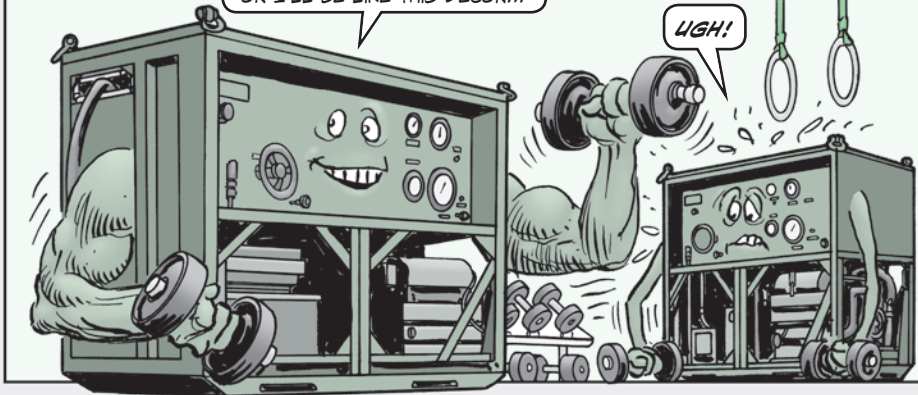

Some M12A1 decons won't pump decon because their fuel injector pumps have stopped pumping. Prevent that problem by keeping fuel injector pumps pumped up with exercise.

When your M12A1 sits for weeks without being run, the fuel injector pump gradually freezes up. Then when you are ready to decon, the engine won't start. The M12A1 is off for repairs and possibly a new fuel injector pump.

Follow the TM and do all the PMCS (before, during, after, quarterly, and annual) on your M12A1, which includes hooking up the entire system, starting it and running water through it. Then the fuel injector pump will have no problem doing its job. So do your job and do PMCS.

Free JSLIST for Training

GOOD NEWS! I'M FREE!!



CBRN specialists, you can get JSLIST for training free through the Individual Chemical Equipment Management Program (ICEMP) by emailing:

icemp.support@us.army.mil

You will be given instructions for ordering the training JSLIST. There is a \$2 shipping charge for each suit. If you have questions, contact the ICEMP hotline at (866) 409-3781 or Valerie Wilson at (404) 464-6215. Email:

valerie.r.wilson@conus.army.mil

COOLANT RESERVOIR NEEDS CARE AND COLLAR

*WATCH IT WITH
THAT COOLANT
RESERVOIR, BUB!*

*THAT THING
CAN TURN INTO A
MISSILE IF YOU
DROP IT!*

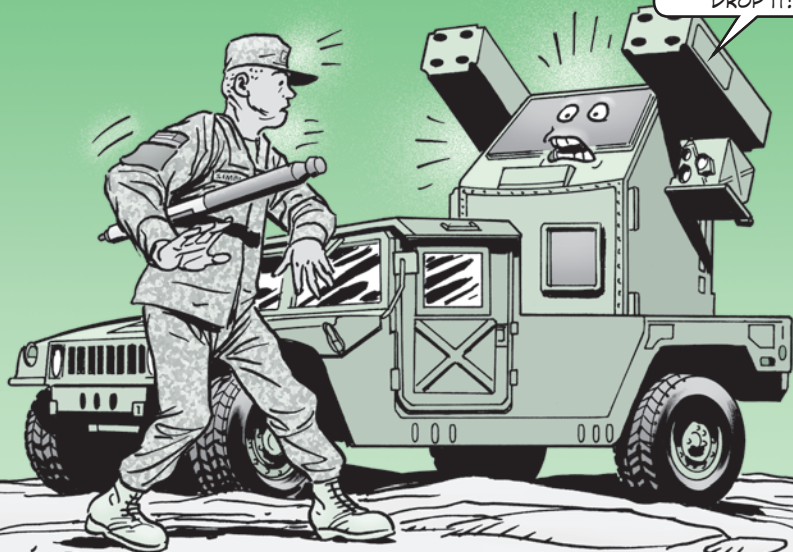

When the Avenger missile system's coolant reservoir is fully charged, it contains argon gas pressurized to 6,000 psi (+/- 200). That is a tremendous amount of pressure.

If you handle the coolant reservoir carelessly, such as tossing or dropping it, the reservoir could rupture and turn itself into a rocket. Anyone unlucky enough to be in its way will be a goner.

So be **very** careful handling the coolant reservoir. And any time you're moving or storing the reservoir, make sure its protective collar is installed. The collar protects the reservoir's male disconnect coupling. If you are missing the collar, order a new one with NSN 1440-01-281-1195.

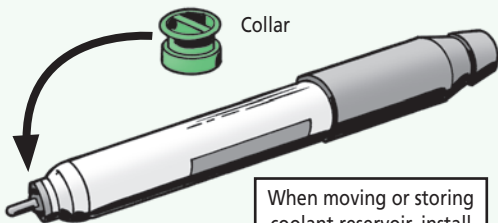

When moving or storing coolant reservoir, install protective collar!

M16-Series Rifle, M4/M4A1 Carbine...

WE'RE GLAD TO SEE YOU OVER HERE IN AFGHANISTAN; MSG HALF-MAST, WE CAN REALLY USE YOUR HELP.

THAT'S FOR SURE! SOME TROOPS HAVEN'T REALLY USED THEIR M16S OR M4S SINCE BASIC TRAINING.

THEY'VE FORGOTTEN SOME NECESSARY PM. IT'D BE **GREAT** IF PS COULD REMIND THEM... GIVE THEM THE **WHOLE PM DEAL** ON RIFLES AND CARBINES.

THAT'S WHAT WE SPECIALIZE IN AT PS; **THE WHOLE PM DEAL!**

The Whole PM Deal



I'M CONTACTING THE PS OFFICE STATESIDE... THEY'LL TRANSMIT ALL THE LATEST INFO.

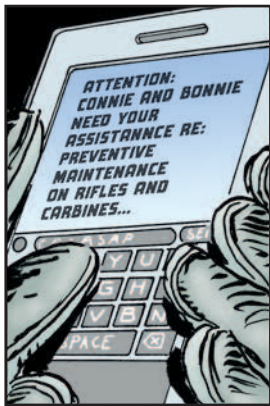

ATTENTION: CONNIE AND BONNIE NEED YOUR ASSISTANCE RE: PREVENTIVE MAINTENANCE ON RIFLES AND CARBINES...

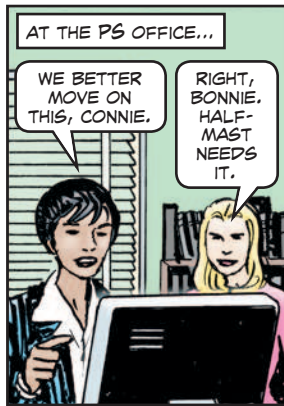

AT THE PS OFFICE...

WE BETTER MOVE ON THIS, CONNIE.

RIGHT, BONNIE. HALF-MAST NEEDS IT.



LET'S BEGIN WITH THE CLEANING BASICS.

BORE

A good cleaning begins with the bore. Carbon quickly builds up there during firing. First swab out the barrel with a patch moistened with CLP to loosen carbon. Change the patch attachment to the brush and remove the rod's handle.

Drop the end of the rod without the brush in the chamber pointing down. Reattach the handle to the end of the rod sticking out the muzzle and pull the rod all the way through. Let the section with the bore brush turn as you pull it through. That way the brush bristles follow the rifling grooves. Don't pull the bore brush through a dry bore or reverse direction. That damages the brush.

Repeat this brush process until all the carbon is gone, periodically running a patch moistened with CLP through the bore to help clean out the carbon.

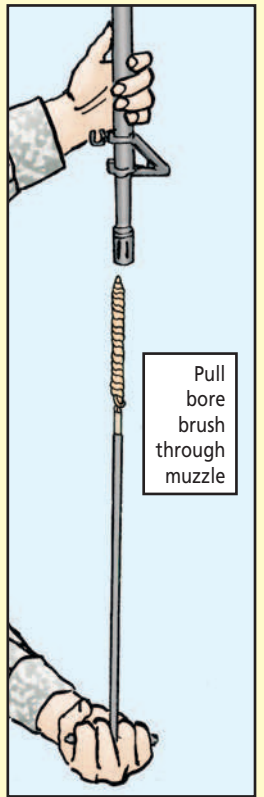

Pull bore brush through muzzle

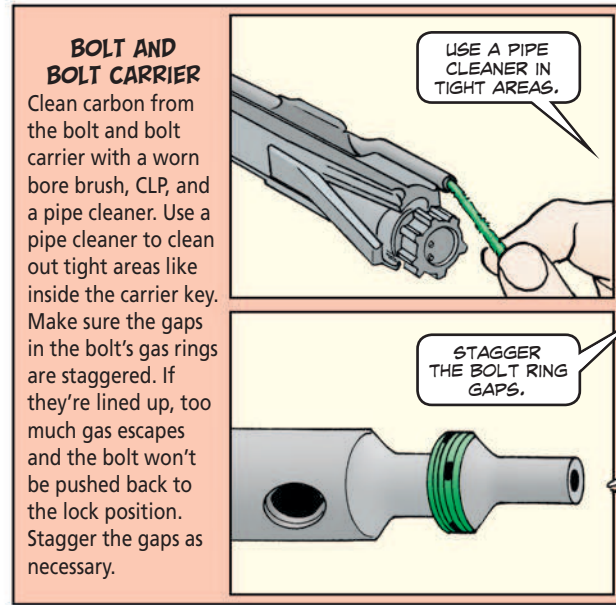

USE A PIPE CLEANER IN TIGHT AREAS.

BOLT AND BOLT CARRIER

Clean carbon from the bolt and bolt carrier with a worn bore brush, CLP, and a pipe cleaner. Use a pipe cleaner to clean out tight areas like inside the carrier key. Make sure the gaps in the bolt's gas rings are staggered. If they're lined up, too much gas escapes and the bolt won't be pushed back to the lock position. Stagger the gaps as necessary.

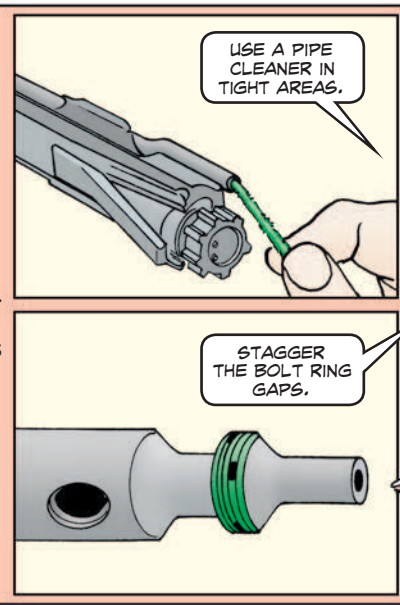

STAGGER THE BOLT RING GAPS.



HERE'S THE INFO ON GAS TUBES AND LOCKING LUGS.

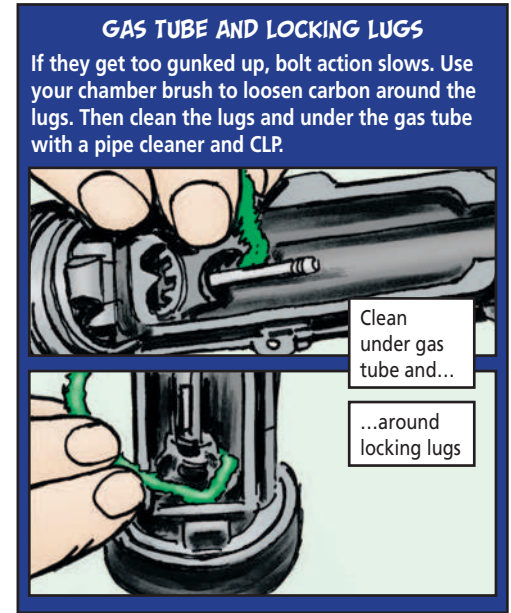

GAS TUBE AND LOCKING LUGS

If they get too gunked up, bolt action slows. Use your chamber brush to loosen carbon around the lugs. Then clean the lugs and under the gas tube with a pipe cleaner and CLP.

Clean under gas tube and...

...around locking lugs

CHARGING HANDLE

If you don't clean the charging handle, eventually you can't charge your rifle or carbine. Pull out the handle from the receiver and clean it with CLP and a cloth. Use a pipe cleaner dipped in CLP to clean out the handle and receiver slots.

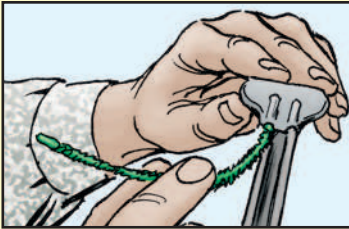

Don't forget charging handle slots

TAKEDOWN AND PIVOT PINS

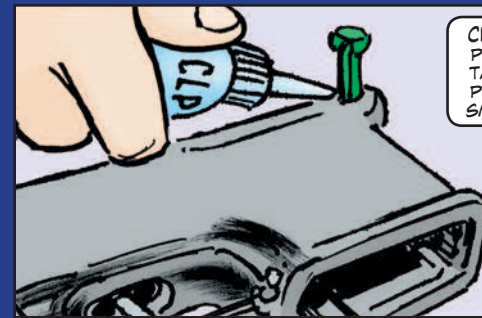

CLP HELPS PIVOT AND TAKEDOWN PINS MOVE SMOOTHLY.

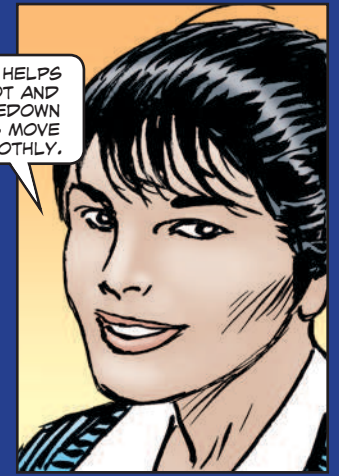

If the pins stick, you'll have trouble disassembling your weapon. Put a strip of CLP down each pin and work them in and out of the receiver until they move easily.

SLIP RING

If the slip ring collects too much sand, you'll have trouble putting on or taking off the handguards. Have a buddy hold down the slip ring with both hands while you work out sand with a dry pipe cleaner or toothbrush. Don't put CLP under the slip ring. Lube attracts more dirt.

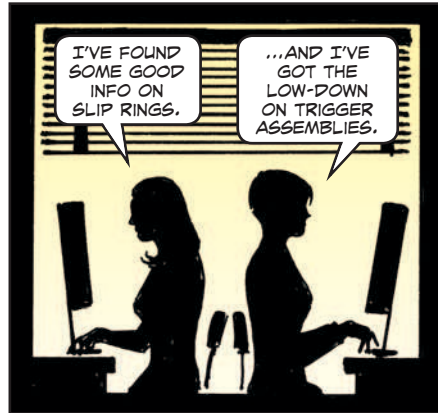

I'VE FOUND SOME GOOD INFO ON SLIP RINGS.

...AND I'VE GOT THE LOW-DOWN ON TRIGGER ASSEMBLIES.

FRONT SIGHT POST

If the post sticks, you can't adjust it. There goes your accuracy. Clean around the post with a toothbrush. Depress the detent and give it a drop of CLP. Work the detent and post up and down until they move smoothly.

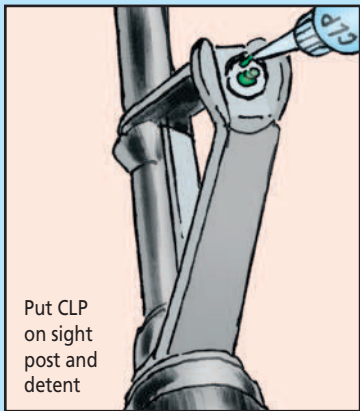

Put CLP on sight post and detent

TRIGGER ASSEMBLY

If the inner workings of the trigger assembly get too dirty, the trigger will bind. The best way to clean out the assembly is to use your own breath to blow out sand. Then put CLP on a pipe cleaner and gently clean out any remaining sand from the assembly.

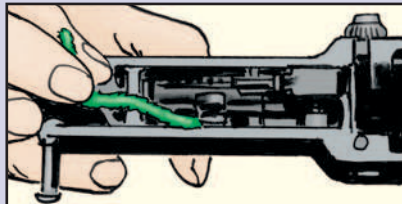

Work pipe cleaner moistened with CLP around trigger assembly

BUTTSTOCK DRAIN HOLE

IF THE HOLE'S CLOGGED, MOISTURE COLLECTS INSIDE THE BUTT-STOCK.

... AND SOON CORROSION IS CHEWING UP THE LOWER RECEIVER. RUN A PIPE CLEANER THROUGH THE HOLE.

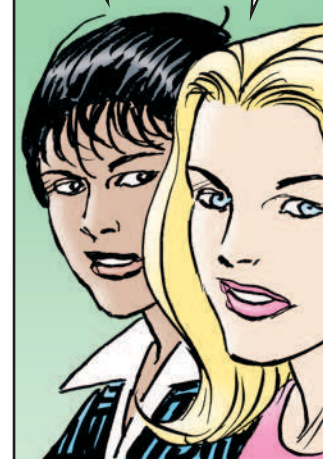

WINDAGE AND ELEVATION KNOBS

If the knobs stick, you can't adjust the rear sight. Put one or two drops of CLP in the hole in front of the rear sight aperture and on each knob. Turn the knobs until they move smoothly. Return them to their original positions.

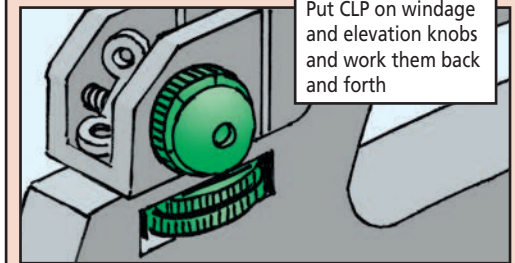

Put CLP on windage and elevation knobs and work them back and forth

FORWARD ASSIST

If the forward assist won't budge, you may not be able to lock the bolt forward. Squirt one shot of CLP in the forward assist port inside the upper receiver. Run the forward assist back and forth until it moves smoothly.



Forward assist needs one shot of CLP

MAGAZINE

No matter how well you've taken care of your M16 or M4, you won't be doing much firing if your magazines are in bad shape. Take each magazine apart. But be careful not to separate the spring from the follower. If they come apart, you will need a new magazine.

Run clean cloth through tube until all dirt is gone

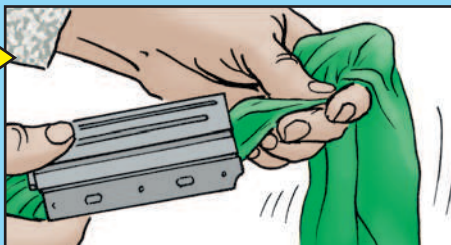

Wipe off dirt from the spring and follower. Lightly lube the spring.

Eyeball all seven magazines for dents, corrosion or bent feed lips. While loading, don't jam the feed lips against anything hard. That bends lips.

Never try to stretch the spring to make it work better. That just ruins the spring.

If you're not on the battlefield, don't leave magazines fully loaded all the time. That wears out the springs.

Keep magazines in their pouch

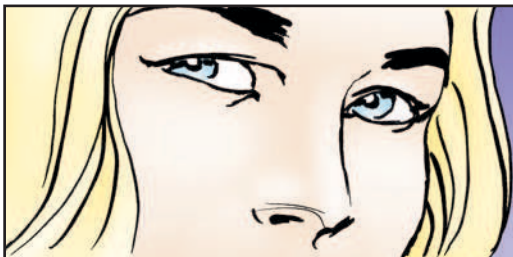
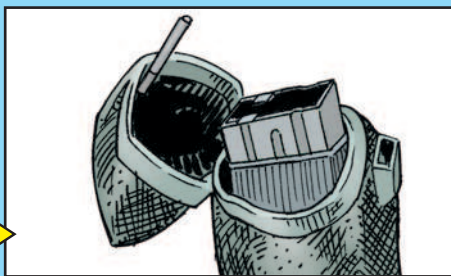

DESERT OPS PRESENT *DIFFERENT* CHALLENGES FOR YOUR M16 AND M4. BECAUSE OF THE HEAT AND SAND, YOU NEED TO FOLLOW THESE RULES...

PM IN DESERT OPERATIONS

Clean your weapon *twice* as often.

I'M READY FOR *ANOTHER* CLEANING.



Generously lube only internal parts.

HEY, KEEP THAT STUFF *OFF* MY OUTSIDE!

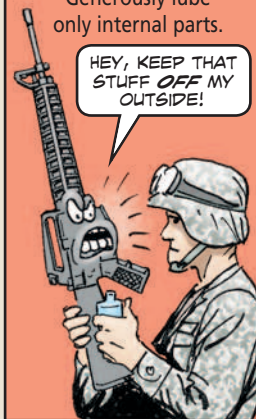

Use the protective dust cap, NSN 5340-00-880-7666, the 30-round magazine pouch mentioned on page 32, and the M16 rifle cover, NSN 1005-00-809-2190, as much as possible to seal out sand.

IN A LOT OF CASES, WHAT YOU SHOULD *NOT* DO TO YOUR M16/M4 IS JUST AS IMPORTANT. SOME SOLDIERS WANT TO DO MORE FOR THEIR WEAPONS THAN THEY'RE TRAINED TO DO. *PROBLEMS RESULT.*

Pay special cleaning attention to surfaces of moving parts, like the bolt carrier.



Wipe down the outside of your weapon as much as possible.



DON'T DISASSEMBLE THE LOWER RECEIVER AND TRIGGER ASSEMBLY FOR BETTER CLEANING!

That enlarges the receiver pin holes and they can't hold the pins. If the trigger assembly is reassembled wrong, the M16/M4 fires in the automatic mode when it's not supposed to.

Leave receiver pins alone

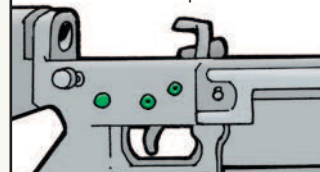

DON'T REMOVE THE BUTTSTOCK TO CLEAN THE LOWER RECEIVER EXTENSION!

Takedown pin spring

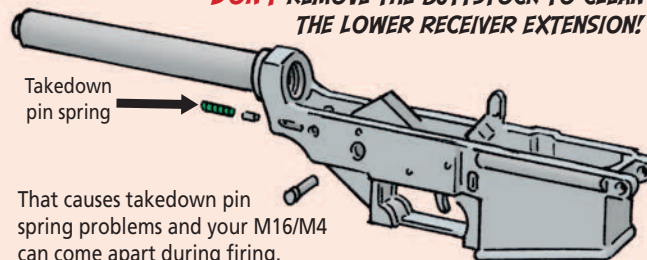

That causes takedown pin spring problems and your M16/M4 can come apart during firing.

DON'T TAKE OFF THE HEAT SHIELDS FOR CLEANING!

That ruins the hand-guards.

DON'T REMOVE THE COMPENSATOR TO CLEAN THE BARREL!

If the compensator is not tightened right when it's reinstalled, then it can vibrate off if it's too loose. But if it's screwed on too tight, the barrel threads are ruined and so is the barrel.

DON'T REMOVE THE SELF-LOCKING SCREW IN THE BUTTSTOCK!

Once the self-locking screw is removed, it no longer stays tight and the buttstock can turn during firing.



DON'T USE STUFF LIKE OVEN, TOILET BOWL, CARBURETOR OR KITCHEN CLEANERS, SHAVING CREAM OR PRODUCTS LIKE SIMPLE GREEN™.

STICK TO TOILETS, PAL!



DON'T USE THE BORE BRUSH ON THE OUTSIDE OF THE WEAPON!

YOU'LL RUIN MY PROTECTIVE FINISH! AND THEN HERE COMES CORROSION!



THAT ABOUT COVERS MIG/M4 PM.

LET'S GIVE HALF-MAST THE WORD.

WHOLE PM DEAL READY TO GO, HALF-MAST.

THE INFO ON THE MIG/M4 YOU ASKED FOR IS READY TO GO.

NOW IT'S YOUR JOB TO MAKE SURE YOUR TROOPS READ IT.



WE WILL. THEIR LIVES DEPEND ON IT.

**OUCH!
DON'T PULL
MY KNOBS!!!**

**CLEAN MY
VISOR TRACKS
FIRST!**

KEEP VISOR TRACKS CLEAN!



The visors have guides that ride in tracks. Sand and dirt build up in the tracks and make raising and lowering the visors difficult. It can also cause the visors to bind or jump out of the tracks.

If you pull on stuck visors, they will break. Then your helmet is NMC until the ALSE tech replaces broken visors.

To keep visors operating smoothly, use a little low pressure air to blow away dirt, grit and sand. If no air is available, use a pipe cleaner to get the gunk out. And resist the temptation to use lubricants. They attract dust and leave a sticky residue.

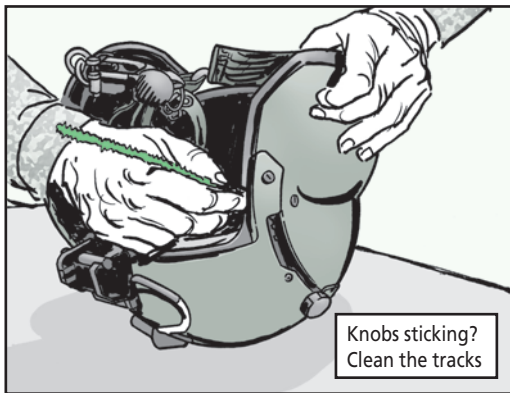

UH-60A...

Water KOs Avionics

THIS IS WHAT HAPPENS WHEN YOU DON'T SEAL THE NOSE COMPARTMENT PROPERLY! BOO-YAH!

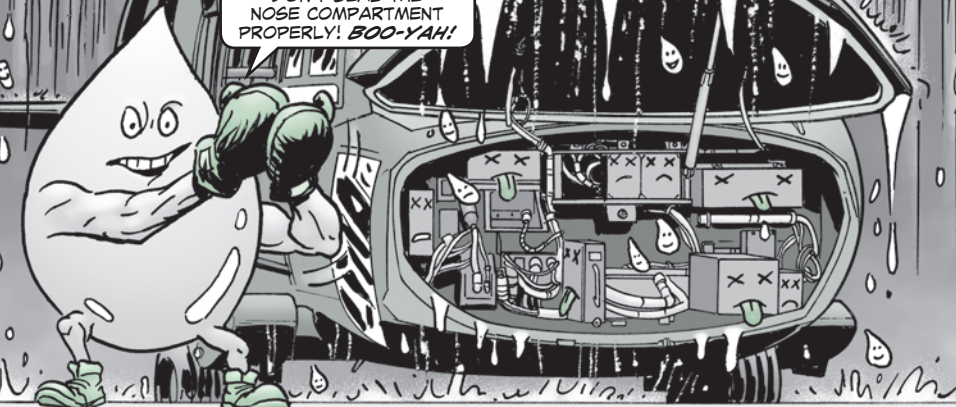

Mechanics, the A-model Black Hawk doesn't have a gutter. So water from rain and washing that gets into the nose compartment through a worn nose door can't get back out. That means damage to avionic components.

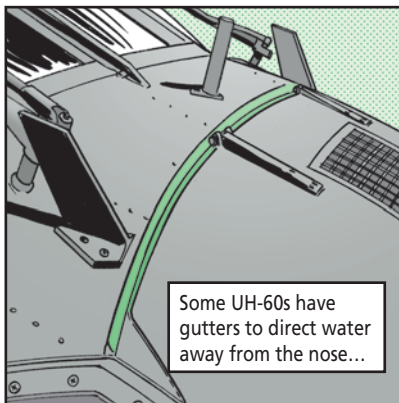

Some UH-60s have gutters to direct water away from the nose...

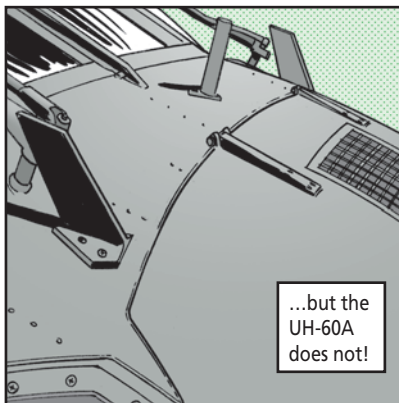

...but the UH-60A does not!

Always make sure you have a good seal in place. If you don't, the attitude & heading reference unit (AHRU), NSN 6605-01-503-5284, and other avionic components are vulnerable to water damage. The AHRU controls the cockpit attitude indicator gauge. If standing water seeps into the AHRU, the gauge is kaput. If that happens, you won't get a correct heading for your bird.

If you're working on an A-model Black Hawk, eyeball the seal around the nose door to make sure it's secure and not worn, cracked, cut or deteriorated. Inspect the seal as part of the nose door inspection daily like it says in TM 1-1520-237-PMD, then **thoroughly** inspect it every 40 hours like it says in TM 1-1520-237-PMS. Replace a bad seal with NSN 5330-01-114-2342.

If you see standing water after rain showers or washing the bird, wipe it up quickly.

So make sure your UH-60A has a good rubber seal around the nose door and keep the compartment dry.

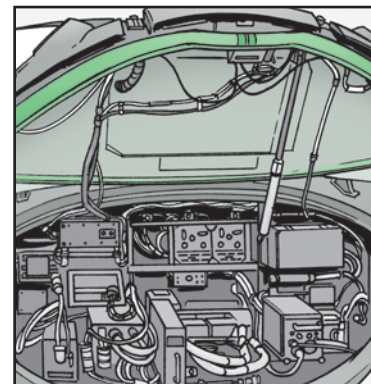

Make sure door seal is in good condition

UH-60 Series...

I THINK WE'RE DONE HERE.

YEAH, LET'S HEAD BACK TO THE HANGER.

WAIT ONE MINUTE!

DID YOU REALLY DO EVERYTHING?

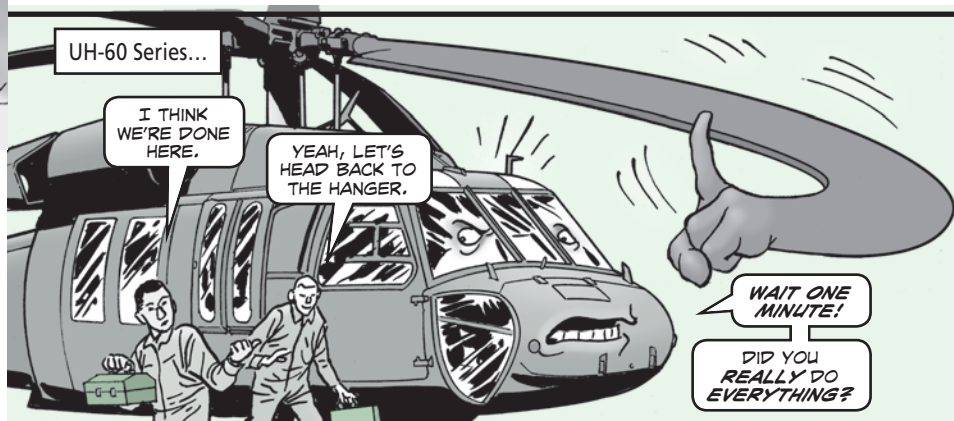

Maintenance is NOT a Dash to the Finish

Crew Chiefs, rushing through Black Hawk pre-flight inspections causes problems in the long run.

Take your time and follow the TM pre-flight procedures step-by-step.

For example, if you get a fault during stabilator checks in auto mode, don't rush through the task. You must follow the troubleshooting procedures to check the stabilator amplifier in the tail cone. Sometimes the gyros in the stabilator burn up and troubleshooting helps locate the problem.

In a rush, some just remove the component and hand it over to the aviation support company (ASC) to fix the problem. Before turning any component in to ASC, troubleshoot it thoroughly. If you can't find the problem, then give it to ASC.

If your troubleshooting fixes the problem, make sure you do the follow-on maintenance like it says in TM 11-1520-237-23 to avoid similar problems later.

Step By Step

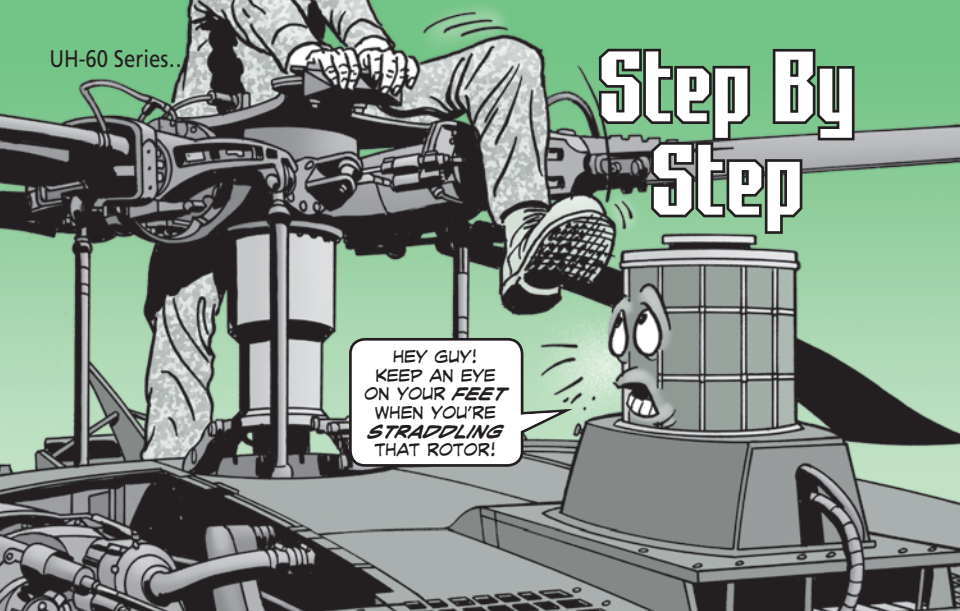

Mechanics, going top-side on your Black Hawk for maintenance or inspections is no time to be foot-loose or fancy-free.

To get where you want on top of your bird, you sometimes have to straddle the rotor blades. That's where your feet can get you in trouble.

Not paying attention to your surroundings or where your feet touch down puts the ALQ-144A/C countermeasure set in harm's way. Stepping over rotor blades and then accidentally kicking the set breaks the window panes. A cracked or broken window pane will not only cost you downtime, but also an expensive trip to your aviation support company for them to fix it.

When you're not checking the countermeasure set but just walking top-side to inspect your bird, protect the set with a cover and a bucket like we told you on Page 38 of PS 652. That way, if you accidentally kick the set, the bucket takes the impact.



Strap Helps Break Seal

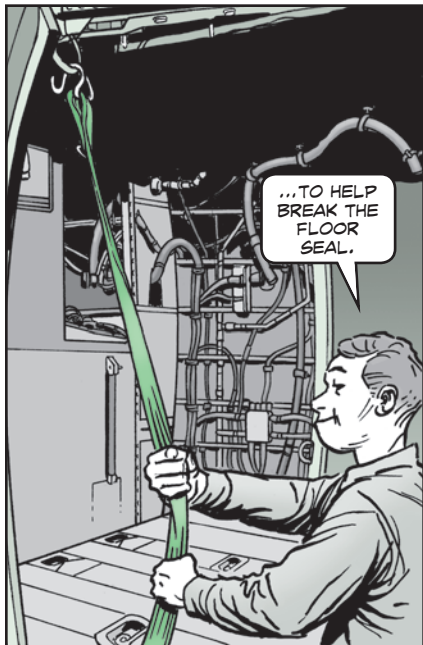
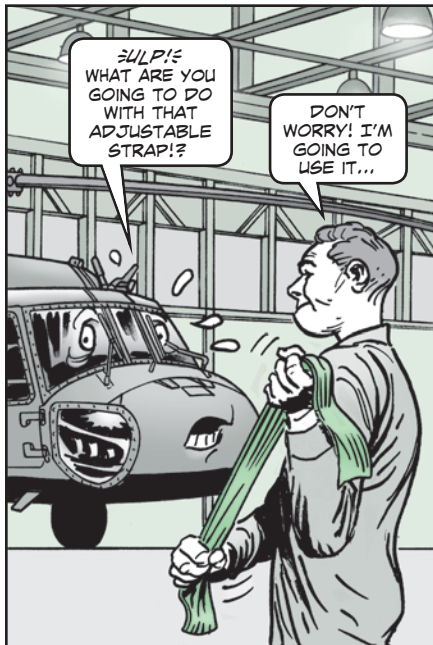

Dear Sergeant Blade,

I know we may be strong, and even Army Strong, but that's not enough when we try to remove a Black Hawk floor.

Black Hawk cabin floors are heavy and even two people may have a problem breaking the floor loose after removing the hardware.

We've come up with an idea using a harness to break the floor loose so it will be easier to get it out of the bird.

With a little ingenuity, we use an adjustable strap with a hook, NSN 1670-00-725-1437 and attach it to the top hook and floor lifting ring to help get the lift started. Once we break the seal, we can get the floor out pretty easily.

SSG J.J. Jones
Ft Hood, TX

Dear Sergeant J.J.,

Sounds like you've solved a heavy-duty problem. Have a buddy help you lift the floors from your bird after you break them loose.

*"Rotor"
Blade*

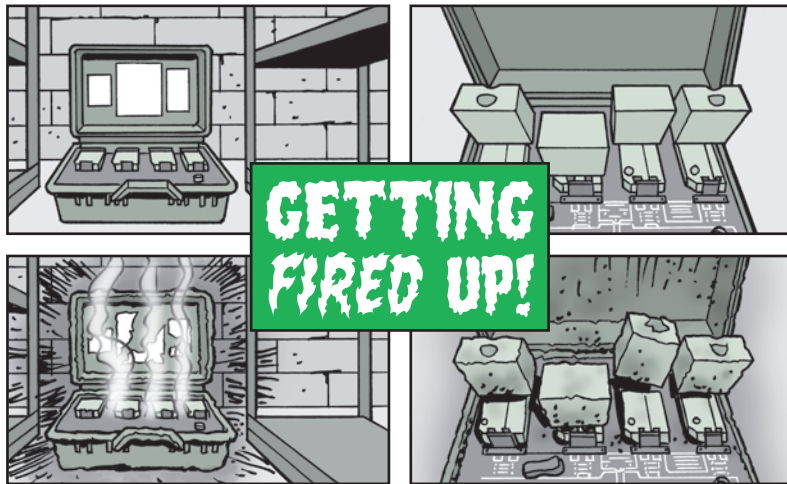

If you use the Soldier portable charger, PP-8498/U, NSN 6130-01-495-2839; the vehicle-mounted charger, PP-8481B/U, NSN 6130-01-527-2726; or the charger-on-the-move, PP-8481A/U, NSN 6130-01-494-9164; you absolutely, positively must have the latest and greatest software installed. If you don't, and you attempt to recharge an old lithium-ion rechargeable battery, your charger could go up in flames!

To prevent a fire from happening, examine the program label on each charger in your commo shop **right now** to determine the software revision level. On the Soldier portable charger, PP-8498/U, the program label is between ports one and two. On the vehicle-mounted charger, PP-8481B/U, the program label is inside the cover next to the window.

On the PP-8498/U, the software level should be H. On the PP-8481B/U, the software level should be C.

What about the charger-on-the-move, PP-8481A/U? This charger is no longer supported with software upgrades. If you must use this charger with old lithium-ion batteries, you must constantly monitor the charging process.

If your inspection of the PP-8498/U or the PP-8481B/U shows that a software upgrade is needed, go to this website:

<https://www.monmouth.army.mil/cecom/lrc/lrchq/power/rechargebat.html>

Once at the website, using a PC or laptop running Windows 95 or newer and using a USB to serial cable like NSN 6150-01-558-7214, you can download the latest software to your charger.

What is considered an old lithium-ion battery? There is no hard and fast rule, but if the battery is older than five years, it's old!

Here are some of the batteries that you need to check for old age:

Battery	NSN 6140-01-
BB-2001A/U	534-3856
BB-2557/U	490-5387
BB-2588/U	493-7623
BB-2600A/U	490-4311
BB-2800/U	490-5372
BB-2847A/U	493-8092

Equipment used in	NSN 6140-01-
AN/PRC-148	487-1153
AN/PRC-152	548-7566
AN/PRC-153	548-7367

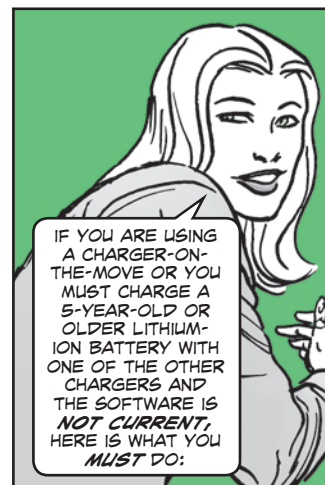

1. Charge no more than two batteries at a time. In the Soldier-portable charger, both batteries can be in Port One. In the vehicle-mounted charger, one battery in adapter A and one in adapter B is permitted.
2. Install the batteries in the charger and then turn it on. (The charger should be off during the installation of the batteries.) Let the charger run for 30 minutes.
3. After 30 minutes, observe the charger indicator lights. If the light is a solid amber, things are going well. Let the charge continue until the light turns green, indicating the battery is fully charged. However, if after 30 minutes of charging, the indicator light is red, blinking amber or no light at all, the battery is defective. Remove it and properly dispose of it!
4. Remember, this is only a temporary solution (except for the charger-on-the-move). The permanent solution is to upgrade the software.



VAA Problems and Solutions

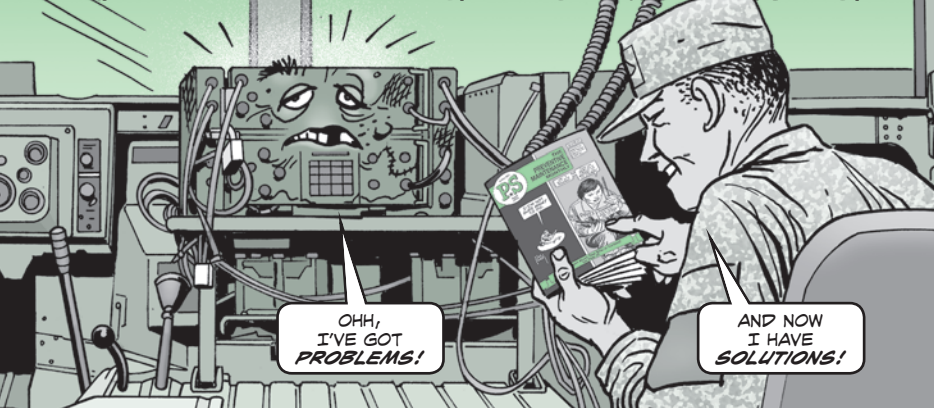

OH, I'VE GOT PROBLEMS!

AND NOW I HAVE SOLUTIONS!

Dear Editor,

The SINCGARS radio vehicular amplifier adapter (VAA) is suffering from abuse and unnecessary downtime. To help end this abuse, I would like to make three points:

First, when you remove the radio and/or PA from the VAA by loosening the thumb screws releasing the clamps that hold the radio and PA, screw the thumb screws back in. This is seldom done and it leaves the screws vulnerable to getting bent or broken. Often when the screws get bent, they cannot be removed and replaced by the user and the VAA must go to support for repair.

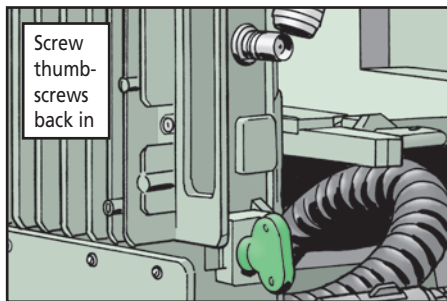

Screw thumb-screws back in

Second, spring-loaded terminals, E1A/B and E2A/B, on top of the VAA become loose or get broken. When this happens, the mounting hardware drops down and then rolls around inside high-voltage circuits. To prevent shorting of internal electrical components, the VAA must be taken out of service immediately and sent to support for repair.



Terminals get loose or break

Third, time and time again over my many years of working with SINCGARS, I have received VAAs with the claim that they "won't power up" or "no power." But 99 percent of the time, they will power up and they do have power! What they don't have is the local (LCL)/remote (RMT) switch set to LCL! If the unit is set to RMT, the unit will fail to power up. Please, check this before you submit a VAA as having no power.

Thanks for listening.

SFC David A. Jones (Ret)
Electronic Tech III, URS
Ft Drum, NY

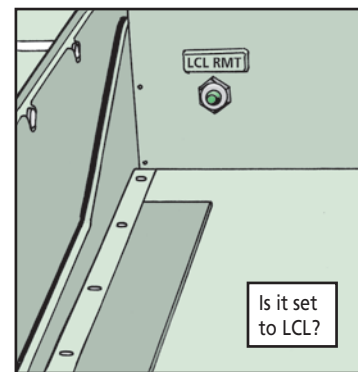

Is it set to LCL?

Editor's note: Sergeant Jones has been at this repair game for 30 years, so he knows what he's talking about. Let this old editor add an addition to point number three: check the power light to make sure the bulb is not burned out or that it's not "shaded." More than a few "no power" submissions can be traced to a burned-out bulb.

LOOP CLAMP NSNs

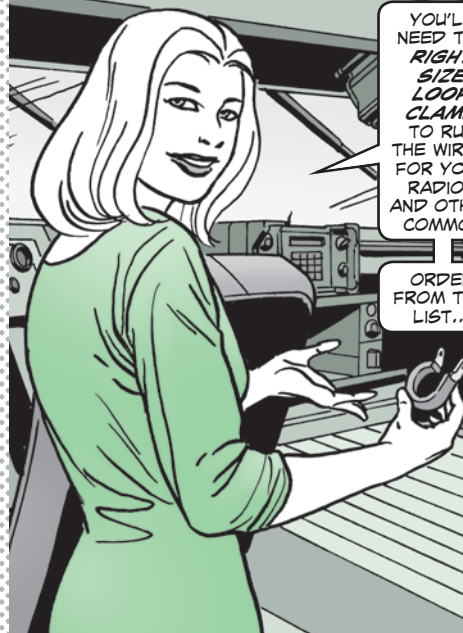

YOU'LL NEED THE RIGHT SIZE LOOP CLAMP TO RUN THE WIRING FOR YOUR RADIOS AND OTHER COMMO!

ORDER FROM THIS LIST...

NSN 5340-00-	Inner Diameter (inches)	Qty
845-2072	.125	1
291-5322	.173	1
291-5323	.235	100
200-8560	.313	1
598-0146	.36	1
200-8559	.438	1
291-5347	.5	1
286-9427	.75	1
286-9424	.875	1
286-9418	1	1
200-7449	1.125	1
200-3045	1.5	1
579-9678	2	1
515-0595	2.25	1
531-6857	2.5	1

SINGGARS...

I THINK WE HAVE TOO MANY SINGGARS RADIOS!

WHAT CAN WE DO WITH ALL OF THESE?

I BELIEVE WE NEED TO CONTACT OUR MACOM FOR REDISTRIBUTION INSTRUCTIONS.

How to Handle Excess Radio Assets

Dear Editor,

It is critical that Active Army units turn in excess SINGGARS radios correctly. To do this, the unit must contact its major command (MACOM) for repair and redistribution instructions. The MACOM will work with the PM FBCB2 that procures and fields tactical voice and data radios and radio systems and with the Army G-8 team that matches available resources to the greatest need.

This includes excess associated equipment like the AM-7238 power amplifier and the AM-7239 vehicular amplifier adapter (VAA).

Units ***MUST NOT*** turn in radios and associated equipment to the wholesale supply system. This is happening too often and fails to get the radios into the hands of those that need them the most.

If you are a National Guard unit with excess to turn in, call (703) 607-5670. If you are an Army Reserve unit with excess to turn in, call (404) 464-8636.

Janet L. Nelson
Chief, MILSATCOM Tactical
Supply Branch LRC
Ft Monmouth, NJ

Editor's note: Thanks, Janet, for passing on this extremely valuable information. Units, also note that if you need to get authorization to receive some of the excess, you need to call DSN 987-3062 or (732) 427-3062, or email:

james.bowden@us.army.mil

and the HQDA G-8 POC, DSN 222-6498 or (703) 692-6498 or email:

ronnie.brown@us.army.mil

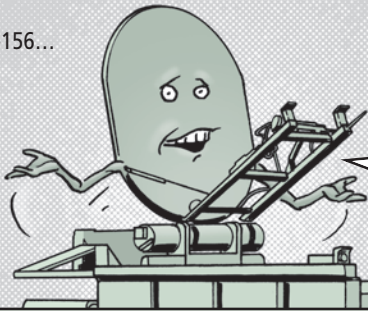

HIGH POWER AMPLIFIER SUBSYSTEM PARTS NEEDED!

Dear Editor,

I manage the AN/TSC-156, Phoenix Tactical SHF Satellite Terminal, NSN 5895-01-542-7716, for C-E LCMC, and I have a shortage problem.

The Phoenix can operate over military satellite frequencies, X-band and Ka-band, and commercial satellite frequencies, C-band and Ku-band. To help them operate, high power amplifier (HPA) subsystems are part of the antenna subsystem. There is a *shortage* of the *HPAs* for the Ka-band, NSN 5996-01-534-6853, and for the tri-band (X-, C-, and KU-), NSN 5996-01-520-9570.

The shortage stems from a couple of problems, but the one I need the Soldiers to help with is turning in unserviceable HPAs for repair. This is not being done!

There is a huge unserviceable credit value for both of these HPAs, so there is monetary incentive for this turn-in!

Allison Chellin
CECOM LRC
APG, MD

AFTER
SUCH A
LONG WAIT
WE FINALLY
GOT THOSE
NEW HIGH
POWER
AMPLIFIERS!

WELL, IT'S TOO BAD
THE PHOENIX'S COVERED
IN MOSS NOW.

NEXT TIME, LET'S
TURN IN THE
UNSERVICEABLES.
WE'LL GET 'EM
BACK FASTER!



Editor's note:

Thanks for the info, Allison. Soldiers, without amplification, signals will not reach the intended satellite and the Phoenix is just a large lump in the road. Check your shops and turn in those unserviceables. By-the-way, the repair time for these HPAs is a lot shorter than the procurement time for a new one. In fact, before a new one comes your way, that bump in the road will be covered with moss.

FIGHTING CABLE CORROSION

THIS MLRS NEEDS ME!

LET ME AT THOSE CORRODED CABLES!!!

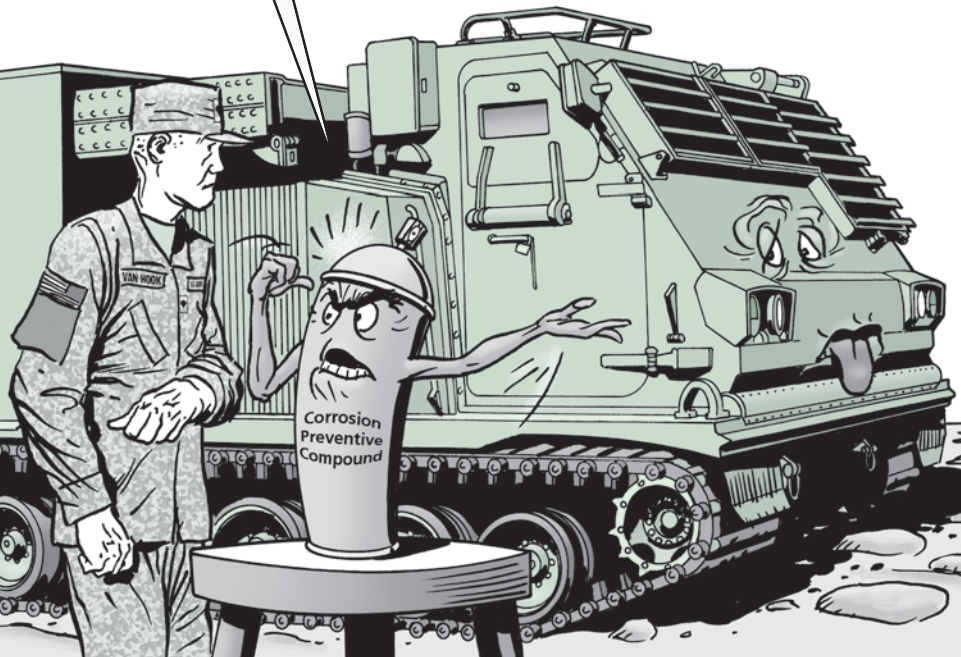

Thousands of electrical cables are used on Army equipment, ranging from the most basic radio systems to complex missile systems and aircraft. All of these cables can be knocked out by corrosion in their connectors. And once the cables are gone, so is the equipment they're powering. That's why you need to do everything possible to fight cable corrosion.

Corrosion takes many different forms, depending on what the cable connector is made of. Corrosion on **aluminum** can be white, gray or black and look like a paste when wet or a hard film or crumbly deposit when dry. On **steel**, corrosion is red, brown or black and looks crusty. On **copper**, it's green or blue and looks like paste when wet. Pitting is also a form of corrosion.

The best way to combat cable corrosion is to apply corrosion preventive compounds (CPCs) to both the inside and outside of connectors on a regular basis.

On the inside of connectors, spray a light coat of MIL-PRF-81309 Type III CPC, NSN 8030-00-546-8637, on the pins and plugs. Do this in a well-ventilated area. That's a light coat! Don't soak the connectors. MIL-PRF-81309 Type III is the only authorized CPC for connector pins and plugs.

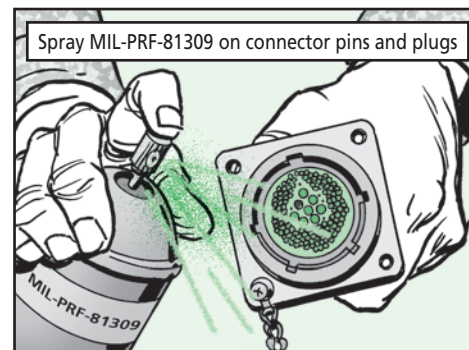

On connector shells and mounting plates, apply a light film of MIL-DTF-85054S Type II CPC, NSN 8030-00-938-1947. Again, just a light coat. This CPC is also good for lubing moving parts like hinges.

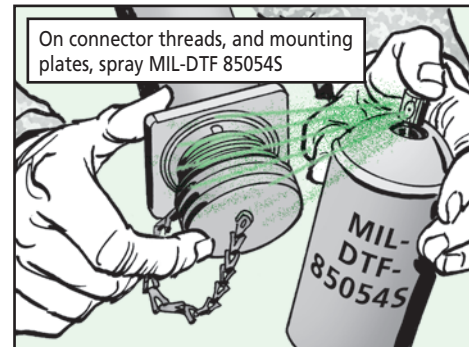

Then, during your weekly PMCS, check for corrosion on connector mating surfaces, threads, shells and mounting plates. Treat them again with CPCs if necessary. Be sure to remove the old CPC residue before applying a new coat.

Other CPCs

MIL-DTL-85054S, NSN 8030-01-347-0979, is good for protecting non-moving metal parts, such as skin seams, fastener heads where paint has cracked, access panel edges, and areas with damaged paint.

Use MIL-L-23398 (solid film lube), NSN 9150-01-260-2534, or MIL-PRF-81302 Type II, NSN 8030-00-938-1947, on sliding components like hinges, turnbuckles, latches, and flap tracks. Solid film lube is also good for protecting areas where paint or protective finish has worn off.

Corrosion POCs

IF YOU HAVE CORROSION QUESTIONS, CONTACT AMCOM'S CORROSION PROGRAM OFFICE'S ROBERT HERRON AT DSN 746-8470; (256) 876-8470; OR EMAIL: robert.a.herron@us.army.mil



SOME LIKE IT HOT!

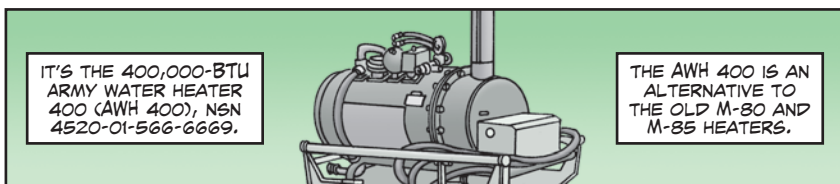
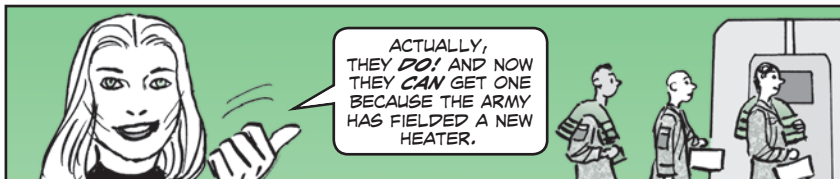

The 500-lb heater is skid-mounted and holds about 33 gallons of water, which are heated by a fuel oil burner. It runs on a variety of fuels, including DF1, DF2, DFA, JP-5 and JP-8. With the exhaust stack, it stands 74 inches high x 32 inches wide x 55 inches long.

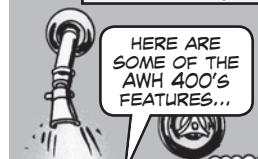

- Delivers water at 9 gallons per minute at temperatures between 60°F and 190°F (16°C and 88°C)

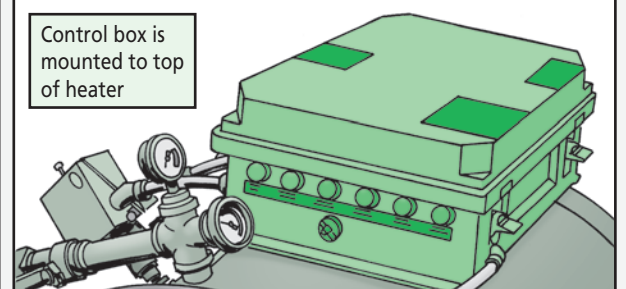

- Automatic safety controls protect against flame failure, low water and scalding hot water.
- Soldiers can operate the controls even if they're wearing arctic mittens or chemical protective gloves.

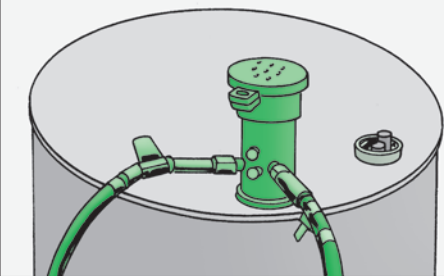

THERE'S AN ARMY TM AVAILABLE FOR THE AWH 400. IT'S TM 10-4520-266-13&P, AND YOU'LL FIND IT ON THE USAMC LOGSA'S ELECTRONIC TECHNICAL MANUALS WEBSITE:
<https://www.logsa.army.mil/etms/online.cfm>



Calvin Long, equipment specialist, DSN 256-6000, (508) 233-6000. Or email: calvin.b.long@us.army.mil

Michael Chandler, item manager, DSN 256-5380, (508) 233-5380. Or email: mike.e.chandler@us.army.mil

M4K Forklift...

FORK UP SOME PM!

WHAT GIVES?
MY FRONT END! IT'S FALLING APART!

IF YOU'RE TRYING TO AVOID A PROBLEM LIKE THIS THEN HERE ARE SOME PM POINTERS TO KEEP IN MIND WHEN MOVING LOADS AT THE WORKSITE.

AS ALWAYS, FOLLOW THE CHECKS AND SERVICES IN TM 10-3930-638-10 BEFORE THE DAY'S RUN.

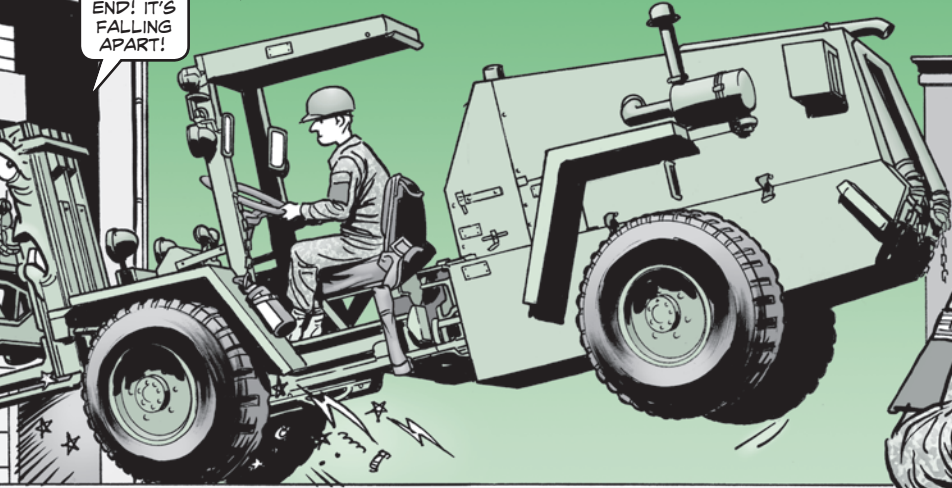

Hydraulic Hoses

Hydraulic hoses on some of these forklifts flop around, dangle and tangle up. They get damaged if they jump off the guide pulleys.

If this happens, replace the old pulley with a new one, NSN 3020-01-172-2787. You'll also need the screw that comes with NSN 5305-00-155-3367.

If the pulley's not the problem, you may be missing hose channels. Before, during and after operation, make sure the hose channels are secured and all there. If any are missing, replace them with these NSNs:

Channel	NSN 3930-01-168-
Main Center	9547
Left Hand	9548

New guide pulleys, NSN 3020-01-172-2787

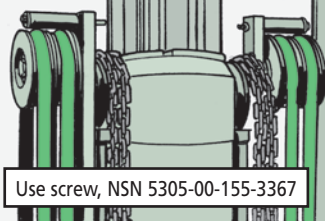

Use screw, NSN 5305-00-155-3367

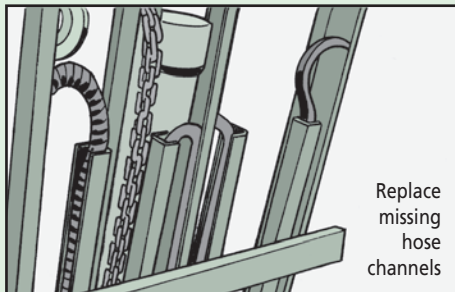

Replace missing hose channels

Loose Fitting Drops Lift

An M4K forklift that can't lift a load isn't a forklift. It's NMC, plain and simple! If you have a forklift that lifts erratically, it probably has a hydraulic leak. The usual suspect is the elbow fitting that connects the hydraulic line to the main hydraulic lift cylinder.

Vehicle vibration and wear and tear loosen the fitting and let hydraulic fluid leak out. A loss of fluid starves the vehicle's hydraulic pump. Then the forklift won't lift.

So, check out that elbow. Raise the forks a foot off the ground and turn off the engine. For safety's sake, use jack stands to block up the cylinder or forks before doing the inspection.

Get on your hands and knees and eyeball the elbow fitting. It's directly under the forklift's lift rack.

If it's leaking, tighten the fitting and add hydraulic fluid until the dipstick shows FULL.

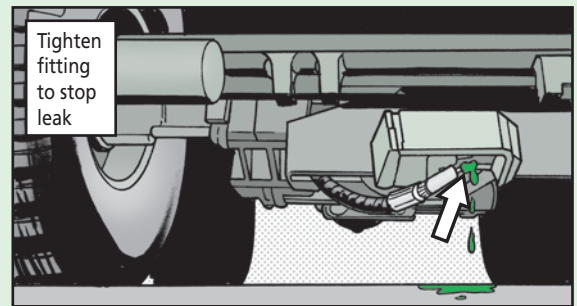



DO YOUR UNIT'S EQUIPMENT READINESS RATINGS HAVE YOU SINGING THE PROPERTY BOOK BLUES?

NOW THERE'S A TOOL THAT CAN HELP YOU CLEAR UP CONFLICTS BETWEEN SAMS-1E AND PBUSE RECORDS!

IF YOU ARE A UNIT-LEVEL SAMS-1E OPERATOR, HERE'S HOW YOU CAN TAKE THIS COOL NEW TOOL FOR A SPIN!

FIRST, BUILD AN AD HOC QUERY IN SAMS-1E'S REPORT GENERATOR, AND THEN SAVE THE RESULTING FILE IN MS EXCEL FORMAT.

NEXT, LOGIN TO LIW...

TAP TAP TAP TAP

LOGSA Offers New Records Reconciliation Tool

Equipment readiness reporting ratings play a key role in unit success. According to AR 700-138, *Army Logistics Readiness and Sustainability*, the Army's equipment readiness goal for ground equipment and missiles is 90 percent fully mission capable. But meeting this goal requires keeping accurate equipment records.

The Logistics Support Activity (LOGSA) recently added a tool to the Logistics Information Warehouse (LIW) to help units reconcile their PBUSE property book records with their SAMS-1E equipment files.

By clearing up invalid, mismatched or duplicate records, units can improve their equipment readiness reporting ratings.



Anyone can access the main LIW website above, but users also have the option to upload files to the LIW regional server that services their specific region:

- ASC East Region (Ft Bragg) <https://liw.bragg.army.mil>
- ASC West Region (Ft Hood) <https://liw.hood.army.mil>
- ARCENT (Kuwait) <https://liw.kuwait.swa.army.mil>
- USAREUR (Germany) <https://liw.aelog.army.mil>
- USARPAC (Hawaii) <https://liw.usarpac.8tsc.army.mil>
- EUSA (Korea) <https://liw.korea.army.mil>



Click the Army ILAP link on the main LIW page, then go the Reports tab and choose File Uploads. Upload your Excel file where it says Upload SAMS-1E Equipment File. Then run the automated reconciliation tool in LIW.

Complete, step-by-step instructions for using the new tool are available for download in LIW. After login, go to the References tab and click on ILAP Documentation.

The reconciliation tool compares your unit's PBUSE and SAMS-1E equipment files. The resulting report includes a list of matching and non-matching NIINs and serial numbers. It also shows your unit's current equipment usage.

Remember, before you edit records in PBUSE or SAMS-1E, any serial number mismatches that popped up during the reconciliation process should be visually verified on equipment data plates.

For more information or assistance with the reconciliation tool in LIW, call ILAP support at (800) 631-8377, or email: support@ilap.army.mil

At LOGSA, contact Joyce L. Myers, DSN 645-9568, (256) 955-9568, or email:

joyce.l.myers@us.army.mil

Training...



ESTABLISH RAPPOR T BEFORE YOU GO

IF YOU'RE DEPLOYING SOON, DON'T FORGET TO PACK A NEW LANGUAGE ALONG WITH YOUR GEAR.



Dari



ALL DEPLOYING ARMY PERSONNEL MUST NOW MEET NEW PRE-DEPLOYMENT LANGUAGE STANDARDS.

The language requirement applies to all deploying Soldiers and Department of the Army civilians, whether or not you are part of a unit deployment.

To help you meet the training goal, your keyboard is a portal to success. By using it, you can access *Rapport*, the Army's new online language training program. The self-paced course gives you the basics of the primary language where you're assigned, plus a cultural orientation to help get you grounded.

The primary language required for Afghanistan is Dari, with additional training in Pashto if requested by your command. For Iraq, the primary language is Iraqi Arabic.

The estimated time needed to complete a *Rapport* course varies from 4 to 6 hours. A minimum passing score of 70 percent is required for credit and a certificate of completion.

Your final score is automatically sent to the Army Training Requirements and Resources System (ATTRS) and your chain of command.



- Select Self Service and then My Training on the drop-down menu
- On the ATTRS gadget, choose Take Self Development Courses. On the left-hand side where it says Quick Course Search, type in "Rapport."
- Choose your preferred language, complete the authentication and submit your application. Processing usually takes less than 15 minutes. You will get an email when your registration is complete.
- Once you get the email, in AKO select My Training and click on ALMS. Your name should appear.
- Click Current Enrollment
- Launch and view the course content
- Complete and pass each task to get a certificate of completion.

IF YOU DON'T HAVE INTERNET ACCESS, COURSE MATERIALS CAN BE ORDERED FROM THE DEFENSE LANGUAGE INSTITUTE FOREIGN LANGUAGE CENTER (DLIFLC) CALL (831) 242-4502.

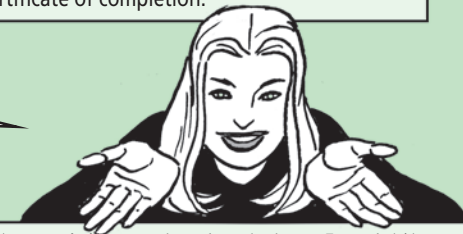

Note: Soldiers or Department of the Army civilians who already have Level 1/1 or higher reading, listening or speaking proficiency and are within 12 months before deployment are exempt from the training requirement. So are personnel who received training from a DLIFLC mobile training team within four months of deployment.

For more information about *Rapport* and the Army's pre-deployment language training requirements, contact the DLIFLC at (831) 242-4502, or submit an RFI at the website: <http://www.dliflc.edu/contact.aspx>



PROPERTY BOOK POINTERS FOR IMPROVING UNIT EOH READINESS

PART IV

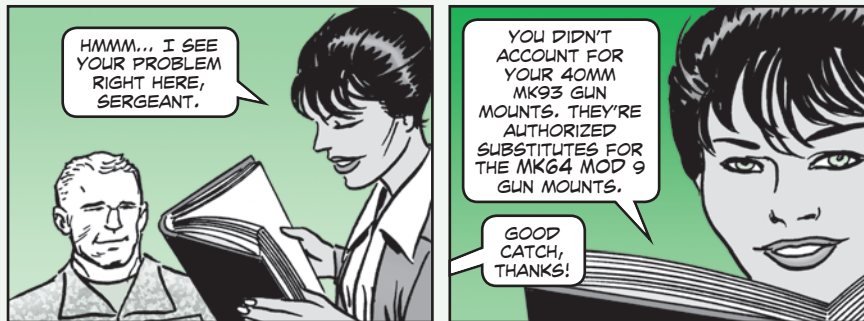
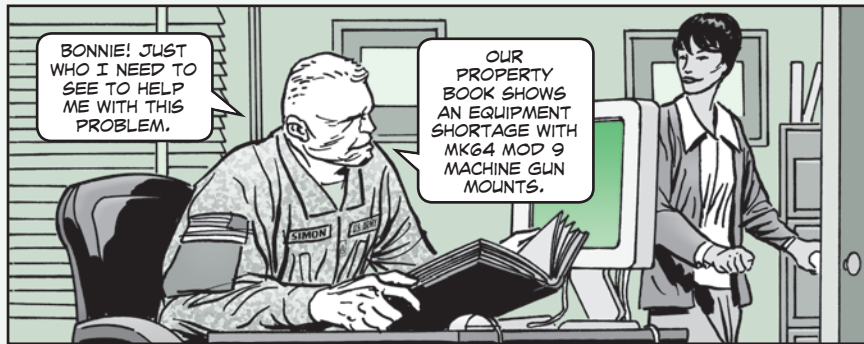

Here in Part IV of a five-part PS mini-series on line item numbers (LINs) that can affect unit readiness reports, we list some LINs in Soldier systems that may cause problems.

Property book officers (PBOs) and supply sergeants should flag these LINs and check their property books. Remember, correcting issues at the property book level can boost the unit's overall readiness ratings.

The following chart lists some problem LINs and their nomenclatures.

Note: Most of the equipment in this series of articles is common to more than one type of Army unit.

LIN	Nomenclature	Issue	Solution
A20044	M4 carbine rail system	Units are not accounting for M4 rail systems in PBUSE.	Account for M4 rail systems in PBUSE. All M4s are issued with rails.

LIN	Nomenclature	Issue	Solution
J03261	PEQ-2/PEQ-15: Illuminator, infrared	Units are not accounting for on-hand PEQ-2/PEQ-15s against PAQ-4 (LIN A34938) MTOE authorizations.	Account for on-hand PEQ-2/PEQ-15s under LIN J03261. Units that possess PAQ-4s (A34938) should turn them in through supply channels.
M09009/ M39263	M249 machine gun	Units are not accounting for LIN M39263 machine guns against the M09009 machine gun authorizations.	Commander directs PBO to generate a lateral transfer (DA Form 3161) in PBUSE, to sub-LIN M39263 under LIN M09009.
M60256	Mount tripod machine gun 7.62mm	Units are not accounting for LIN M75964 (M122A mount tripod machine gun mounts) or LIN M75714 (M122 mount tripod machine gun mounts) against LIN M60256 mount tripod machine gun authorizations.	Commander directs PBO to generate a lateral transfer (DA Form 3161) in PBUSE, to sub-LIN M75964 and M75714 under M60256.
M74823/ M12647	Mount machine gun MK64 MOD 9/ mount machine gun 40mm MK93	Units are not accounting for 40mm MK93 machine gun mounts as authorized substitutes for MK64 MOD 9 machine gun mounts and vice versa.	Commander directs PBO to generate a lateral transfer (DA Form 3161) in PBUSE, to sub-LIN M12647 under LIN M74823 and vice-versa.
M79678	AN/PVS-14: Monocular night vision device	Units are not accounting for A N/PVS-14s against the NVG AN/PVS-7 (LIN N05482) authorizations.	Commander directs PBO to generate a lateral transfer (DA Form 3161) in PBUSE, to sub-LIN N05482 under LIN M79678 and vice-versa.

LIN	Nomenclature	Issue	Solution
R45601	M-110 sniper rifle	Commanders/units are not aware they can count the M-110 sniper rifle as a valid ILO weapon system for the M24 sniper weapon system for LIN R95387.	Commander directs PBO to generate a lateral transfer (DA Form 3161) in PBUSE, to sub-LIN R45601 under the M24 sniper rifle LIN (R95387), and vice versa.
S25681	Shop equipment contact maint (SECM) ORD/ENG truck mounting	Project managers are fielding SECMs under a non-standard LIN (MB400U), which causes units to report shortages under the standard SECM LIN. Units are also retaining the older S25681 as a valid MTOE equipping requirement, even though it has been replaced by the MB400U version.	Commander directs PBO to generate a lateral transfer (DA Form 3161) in PBUSE, to sub-LIN MB400U under LIN S25681 and other LINs as appropriate.
S45729	M150 rifle combat optic (RCO)/ advanced combat optical gun sight (ACOG)	Units are not accounting for the RCO/ACOG under the correct LIN (S45729).	Commander directs PBO to generate a lateral transfer (DA Form 3161) in PBUSE, to sub-LIN GA4067 and S60288 under LIN S45729 and other LINs as appropriate.
Z01059	AN/PVS-26: Sight night vision sniperscope	Commanders/units are not aware they can count the AN/PVS-26 night vision sniper scope as a valid ILO sniper sight for the AN/PVS-10 night vision sniper scope (S90433).	Commander directs PBO to generate a lateral transfer (DA Form 3161) in PBUSE, to sub-LIN Z01059 under LIN S90433 and vice versa.

If you have questions, contact: Mark Moore, DSN 225-4513, (703) 695-4513, or email: mark.moore@us.army.mil



Use the AEPS Network

THE ARMY ELECTRONIC PRODUCT SUPPORT (AEPS) NETWORK GIVES YOU FAST ACCESS TO SUPPLY AND MAINTENANCE INFORMATION!



AEPS gives alerts and messages you need to operate equipment safely and trouble-free. Messages include:

- ground precautionary
- maintenance advisory
- safety of use
- safety advisory
- safety of flight

AEPS also lets you check out equipment MWOs and submit online quality deficiency reports and DA Form 2028s, *Recommended Changes to Publications and Blank Forms*. You can even track the status of parts shipments.

To get started, go to the AEPS public website:

<https://aeps.ria.mil/aeppublic.cfm>

Click on the Access Request Form and follow the instructions. Your AEPS access will begin when you get your user ID.



GOT QUESTIONS? CALL AEPS AT DSN 793-0699; (888) LOG-HELP (564-4357); OR E-MAIL: rock-aeps-helpdesk@conus.army.mil



Connie's POST SCRIPTS

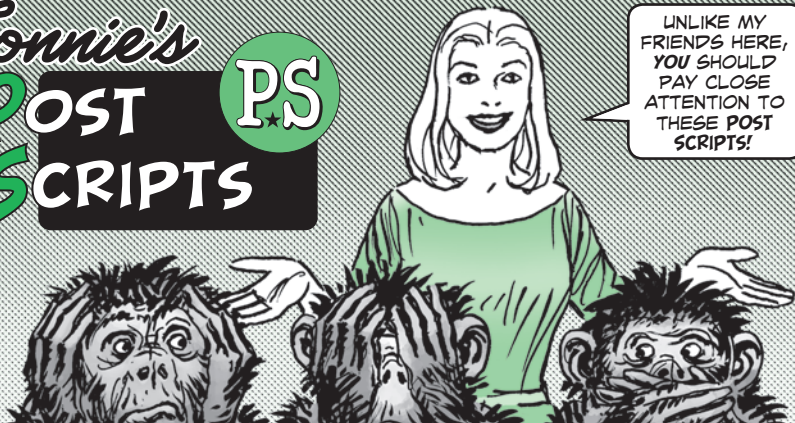

NEW NSN FOR M113A2 FOV STEERING LINKAGE COTTER PIN

Get a new cotter pin for the steering linkage on your M113A2 FOV with NSN 5315-01-359-1451. NSN 5315-00-816-1794, which is shown as Item 10 in Fig 41, Item 3 in Fig 166, Item 18 in Fig 167, and Item 4 in Fig 168 of TM 9-2350-261-24P (Aug 05), is a terminal item. Also note that the old NSN brought 100 cotter pins. The replacement NSN brings only one. The old cotter pin is shown in numerous other places throughout the TM. Use the replacement NSN in each of these instances, too.

ARMY EXPLOSIVES SAFETY CONFERENCE

The Army Explosives Safety Conference will be held June 21-23 at Redstone Arsenal, AL. The conference will provide information on explosives safety, new ammo technologies and processes, in-theater ammo issues, HERO (hazards of electromagnetic radiation to ordnance), and ammo safety training. The conference is free and open to all military and federal employees. To register for the conference, go to:

<https://www3.dac.army.mil>

M915 FOV Air Filter NSNs

Ever wonder if the air filters for the M915 family of vehicles are one size fits all? Well, they're not. Eyeball the following chart to get the air filters you need for the models in your unit.

NSN 2940-01-	Models Used On
065-8396	M915; M915A1; M916; M917; M918; M919; M920
514-2457	M915A2; M915A3; M915A4; M916A1; M916A2; M916A3; M917A1; M917A2
576-2731	M915A5

M1117 ASV Hawker Battery

The AGM Hawker Armasafe Plus battery, NSN 6140-01-485-1472, is now approved for use in the armored security vehicle (ASV). The battery that's currently used in the vehicle and shown in the TMs is still OK, too. Just **don't mix it** with the Hawker battery. Remember, **all** batteries installed in the vehicle need to be the same type.

M2A2/M3A2, M2A2/M3A2 ODS Bradley Decals

Take note if you want to order one of the two ISU decals shown as Items 72 and 73 in Fig 126 of TM 9-2350-284-24P-2 (Jul 02). If you order Item 72, you'll get Item 73 and vice versa. Switch the information for both until the TM can be updated.

ASV Evaporator Coil

Use NSN 1010-01-587-7637 to get the rear evaporator coil for the M1117 armored security vehicle (ASV). This NSN replaces the parts info shown as Item 30 in Fig 225 of TM 9-2320-307-24P.

M1000 HET Semitrailer Steering Link Bolt

Use NSN 5305-00-719-5240 to get a new steering link bolt for your M1000 HET semitrailer. It replaces NSN 5305-00-719-5239, which is shown as Items 12 and 36 in Fig 31 of TM 9-2330-381-24P (Jun 09). You'll also need a different self-locking nut to secure those new bolts. NSN 5310-00-877-5795 is the replacement for NSN 5310-00-902-9369, which is shown as Items 15 and 26. Make a note until the TM is updated.

M871R-SERIES PNEUMATIC WHEEL ASSEMBLY

To get the pneumatic wheel assembly for the 40-ton medium heavy equipment transporter, use NSN 2530-01-571-7223. This NSN replaces the parts info shown for Item 1 in Fig 19 of TM 5-2330-325-14-P.

M871R-Series Wheel Rim Assembly

To get a hub-piloted one-piece wheel assembly, 11R x 22.5-in tire, for the M871R (RESET) 22 1/2-ton semitrailer, use NSN 2530-01-584-7914.

NEED SOME GLUE?

Sometimes the only way to hold stuff together is with some glue. So what to use? Get a package of 12, 3-gram tubes of ethyl cyanoacrylate, also known as Super Glue®, with NSN 8040-01-024-6988. It's good for bonding both rubber and plastic to metal. Or, if you're looking for something that doesn't dry quite as fast, try NSN 8040-00-777-0631. That gets a two-part epoxy kit for general-purpose bonding, sealing and repairing of metal, wood, rubber and plastic.

DISTRIBUTION: To be distributed in accordance with the initial distribution number (IDN) 340312, requirements for TB 43-PS-Series.

Would You Stake Your Life ^{right now} on the Condition of Your Equipment?

**GIVE ROADWHEEL HUBS
THE BACK OF YOUR HAND!**

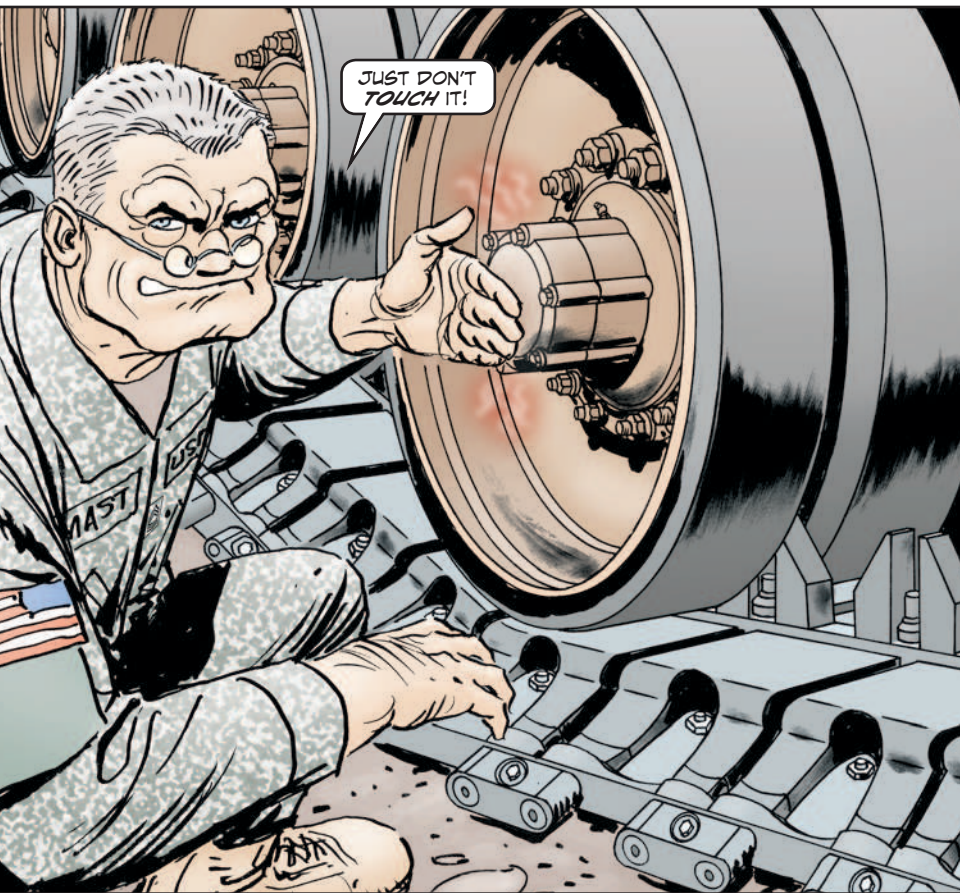

**EXCESSIVE HEAT
COULD MEAN THEY NEED
MORE LUBE!**